

NEW EDITION

Endorsed by
University of Cambridge
International Examinations

EXTENDED
MATHEMATICS
FOR
IGCSE

DAVID RAYNER



OXFORD

OXFORD

UNIVERSITY PRESS

Great Clarendon Street, Oxford OX2 6DP

Oxford University Press is a department of the University of Oxford. It furthers the University's objective of excellence in research, scholarship, and education by publishing worldwide in

Oxford New York

Auckland Cape Town Dar es Salaam Hong Kong Karachi
Kuala Lumpur Madrid Melbourne Mexico City Nairobi
New Delhi Shanghai Taipei Toronto

With offices in

Argentina Austria Brazil Chile Czech Republic France Greece
Guatemala Hungary Italy Japan South Korea Poland Portugal
Singapore Switzerland Thailand Turkey Ukraine Vietnam

Oxford is a registered trade mark of Oxford University Press in the UK and in certain other countries

© David Rayner 2005

The moral rights of the author have been asserted

Database right Oxford University Press (maker)

First published 2005

12 11 10 9 8 7 6 5 4 3

All rights reserved. No part of this publication may be reproduced, stored in a retrieval system, or transmitted, in any form or by any means, without the prior permission in writing of Oxford University Press, or as expressly permitted by law, or under terms agreed with the appropriate reprographics rights organisation. Enquiries concerning reproduction outside the scope of the above should be sent to the Rights Department, Oxford University Press, at the above address

You must not circulate this book in any other binding or cover and you must impose this same condition on any acquirer

British Library Cataloguing in Publication Data

Data available

ISBN 0 19 914994 1
ISBN 9 780199 149940

Typeset by Tech-Set Ltd.
Printed and bound in Great Britain

Acknowledgements

The publishers would like to thank Cambridge International Examinations for kind permission to reproduce past paper questions. Cambridge International Examinations accept no responsibility for the answers to past paper questions.

Cover photo by Corbis UK Ltd/Digital Art

Oxford University Press is a worldwide publisher of educational textbooks and we have made full use of our international reputation to bring you the most authoritative text for the Extended IGCSE syllabus.

About this book

This book is designed to provide the best preparation for your IGCSE examination. It is written by a very popular and successful author, and is fully endorsed for the CIE syllabus so you can be sure it covers everything you need to know.

Finding your way around

To get the most out of this book when studying or revising, use the:

- **Edge marks** to help you find the unit you want quickly.
- **Contents list** to help you find the appropriate units.
- **Index** to find key words so you can turn to any concept straight away.

Exercises and exam questions

There are literally thousands of questions in this book, providing ample opportunities to practise the skills and techniques required in the exam.

- **Worked examples and comprehensive exercises** are main features of the book. The examples show you the important skills and techniques required. The exercises are carefully graded, starting from the basics and going up to exam standard, allowing you to practise the skills and techniques.
- **Revision exercises** at the end of each unit allow you to bring together all your knowledge on a particular topic and encourage regular revision.
- **Examination exercises** at the end of each unit consist of questions from past IGCSE papers. They are coded so you can tell immediately which paper they are taken from: [J 95 2] means the question is from June 95 Paper 2; [N 98 4] is from November 98 Paper 4.
- **Specimen exam papers** at the end of the book are written by the Principal Examiner. There are two papers, corresponding to the papers you will take at the end of your course: Paper 2 and Paper 4. They give you the opportunity to practise for the real thing.
- **Revision section:** Unit 12 contains multiple choice questions to provide an extra opportunity to revise, making sure you are completely ready for your exam.
- **Answers to numerical problems** are at the end of the book so you can check your progress.

Investigations

Unit 11 provides plenty of ideas to help you gain the special skills required for the Investigation paper. Remember that you can only gain by taking this optional paper – you cannot lose marks – so it is worth developing these skills.

Links to curriculum content

At the start of each unit you will find a list of objectives that are covered in the unit. These objectives are drawn from the Core and Supplement as described in the IGCSE Mathematics syllabus.

- 17** Apply rate of change to distance–time and speed–time graphs
- 18** Construct tables of values and draw graphs for functions of the form ax^n ; estimate gradients of curves by drawing tangents
- 19** Interpret and obtain the equation of a straight-line graph in the form $y = mx + c$; calculate the gradient of a straight line from the coordinates of two points on it

The number attached to each objective is the topic number as given in the syllabus provided by the CIE examination board. It is for ease of reference and to help you to plan your study.

Contents

1 ✓	Number	1 – 43
2 ✓	Algebra 1	44 – 81
3 ✓	Mensuration	82 – 113
4 ✓	Geometry	114 – 152
5 ✓	Algebra 2	153 – 181
6 ✓	Trigonometry	182 – 210
7 ✓	Graphs	211 – 240
8 ✓	Sets, Vectors and Functions	241 – 273
9	Matrices and Transformations	274 – 306
10	Statistics and Probability	307 – 342
11	Investigations, Practical Problems, Puzzles	343 – 365
12	Revision Tests	366 – 377
	Specimen examination papers	378 – 387
	Answers	388 – 443
	Index	444 – 448



Contents

✓ 1	Number	1-43
1.1	✓ Arithmetic	2
1.2	✓ Number facts and sequences	5
1.3	✓ Approximations and estimation	8
1.4	✓ Standard form	13
1.5	✓ Ratio and proportion	15
1.6	✓ Percentages	21
1.7	✓ Speed, distance and time	28
1.8	✓ Calculator	33
1.9	Using a spreadsheet on a computer	35
	Revision Exercise 1A	38
	Examination Exercise 1B	41
✓ 2	Algebra 1	44-81
2.1	✓ Directed numbers	44
2.2	✓ Formulae	46
2.3	✓ Brackets and simplifying	50
2.4	✓ Linear equations	52
2.5	✓ Problems solved by linear equations	57
2.6	✓ Simultaneous equations	62
2.7	✓ Problems solved by simultaneous equations	65
2.8	✓ Factorising	68
2.9	✓ Quadratic equations	71
need to review ↙ 2.10	✓ Problems solved by quadratic equations	74
	Revision Exercise 2A	77
	Examination Exercise 2B	80
✓ 3	Mensuration	82-113
3.1	✓ Area	82
3.2	✓ The circle	87
3.3	✓ Arc length and sector area	91
3.4	✓ Chord of a circle	95
3.5	✓ Volume	97
3.6	✓ Surface area	105
	Revision Exercise 3A	107
	Examination Exercise 3B	110
✓ 4	Geometry	114-152
4.1	✓ Fundamental results	115
4.2	✓ Pythagoras' theorem	119
4.3	✓ Symmetry	122
4.4	✓ Similarity	124
4.5	✓ Circle theorems	134
4.6	✓ Constructions and loci	142
4.7	✓ Nets	145
	Revision Exercise 4A	146
	Examination Exercise 4B	148

4.5	Algebra 2	153–181	9	Matrices and Transformations	274–306
5.1	✓ Algebraic fractions	153	9.1	Matrix operations	274
5.2	✓ Changing the subject of a formula	156	9.2	The inverse of a matrix	277
5.3	✓ Variation	162	9.3	Simple transformations	279
5.4	✓ Indices	167	9.4	Combined transformations	289
5.5	✓ Inequalities	170	9.5	Transformations using matrices	292
5.6	Linear programming	174		Revision Exercise 9A	300
	Revision Exercise 5A	178		Examination Exercise 9B	303
	Examination Exercise 5B	180			
6	Trigonometry	182–210	10	Statistics and Probability	307–342
6.1	✓ Right-angled triangles	182	10.1	✓ Data display	307
6.2	✓ Scale drawing	193	10.2	✓ Mean, median and mode	315
6.3	✓ Three-dimensional problems	194	10.3	✓ Cumulative frequency	324
6.4	✓ Sine, cosine, tangent for any angle	197	10.4	✓ Simple probability	327
6.5	✓ The sine rule	199	10.5	✓ Exclusive and independent events	331
6.6	✓ The cosine rule	202	10.6	✓ Tree diagrams	333
	Revision Exercise 6A	206		Revision Exercise 10A	337
	Examination Exercise 6B	208		Examination Exercise 10B	339
7	Graphs	211–240	11	Investigations, Practical Problems, Puzzles	343–365
7.1	Drawing accurate graphs	211			
7.2	Gradients	213	11.1	Investigations	343
7.3	The form $y = mx + c$	215	11.2	Practical problems	359
7.4	Linear laws	216	11.3	Puzzles and experiments	361
7.5	Plotting curves	217			
7.6	Interpreting graphs	224	12	Revision Tests	366–377
7.7	Graphical solution of equations	225		Test 1	366
7.8	Distance–time graphs	229		Test 2	369
7.9	Speed–time graphs	232		Test 3	371
	Revision Exercise 7A	235		Test 4	374
	Examination Exercise 7B	238			
8	Sets, Vectors and Functions	241–273		Specimen Paper 2	378 – 382
8.1	✓ Sets	241		Specimen Paper 4	383 – 387
8.2	✓ Logical problems	247		Answers	388 – 443
8.3	✓ Vectors	250		Index	444 – 448
8.4	Column vectors	255			
8.5	Vector geometry	261			
8.6	✓ Functions	265			
	Revision Exercise 8A	270			
	Examination Exercise 8B	272			

1 NUMBER



Karl Friedrich Gauss (1777–1855) was the son of a German labourer and is thought by many to have been the greatest all-round mathematician of all time. He considered that his finest discovery was the method for constructing a regular seventeen-sided polygon. This was not of the slightest use outside the world of mathematics, but was a great achievement of the human mind. Gauss would not have understood the modern view held by many that mathematics must somehow be ‘useful’ to be worthy of study.

- 1** Identify and use natural numbers, integers, prime numbers, square numbers, rational and irrational numbers; continue a given number sequence; recognise patterns in sequences and generalise to simple algebraic statements
- 6** Use the standard form $A \times 10^n$
- 7** Use the four rules for calculations with whole numbers, decimal fractions and vulgar fractions
- 8** Make estimates, give approximations and round off answers to reasonable accuracy
- 9** Obtain appropriate upper and lower bounds to solutions of simple problems
- 10** Demonstrate an understanding of ratio, direct and inverse proportion and common measures of rate; divide a quantity in a given ratio; use scales in practical situations; calculate average speed
- 11** Calculate percentage increase or decrease; carry out calculations involving reverse percentages
- 12** Use an electronic calculator efficiently
- 15** Calculate using money and convert from currency to another
- 16** Solve problems on simple interest and compound interest

1.1 Arithmetic

Decimals

Example

Evaluate: (a) $7.6 + 19$ (b) $3.4 - 0.24$ (c) 7.2×0.21

(d) $0.84 \div 0.2$ (e) $3.6 \div 0.004$

$$\begin{array}{r} \text{(a)} \quad 7.6 \\ + 19.0 \\ \hline 26.6 \end{array}$$

$$\begin{array}{r} \text{(b)} \quad 3.40 \\ - 0.24 \\ \hline 3.16 \end{array}$$

$$\begin{array}{r} \text{(c)} \quad 7.2 \\ \times 0.21 \\ \hline 72 \\ 1440 \\ \hline 1.512 \end{array}$$

No decimal points in the working, '3 figures after the points in the question *and* in the answer'.

(d) $0.84 \div 0.2 = 8.4 \div 2$

$$\begin{array}{r} 4.2 \\ 2 \overline{)8.4} \end{array}$$

Multiply both numbers by 10 so that we can divide by a whole number.

(e) $3.6 \div 0.004 = 3600 \div 4 = 900$

Exercise 1

Evaluate the following without a calculator:

- | | | | |
|---------------------------------|-------------------------------|------------------------------------|---|
| 1. $7.6 + 0.31$ | 2. $15 + 7.22$ | 3. $7.004 + 0.368$ | 4. $0.06 + 0.006$ |
| 5. $4.2 + 42 + 420$ | 6. $3.84 - 2.62$ | 7. $11.4 - 9.73$ | 8. $4.61 - 3$ |
| 9. $17 - 0.37$ | 10. $8.7 + 19.2 - 3.8$ | 11. $25 - 7.8 + 9.5$ | 12. $3.6 - 8.74 + 9$ |
| 13. $20.4 - 20.399$ | 14. 2.6×0.6 | 15. 0.72×0.04 | 16. 27.2×0.08 |
| 17. 0.1×0.2 | 18. $(0.01)^2$ | 19. 2.1×3.6 | 20. 2.31×0.34 |
| 21. 0.36×1000 | 22. $0.34 \times 100\,000$ | 23. $3.6 \div 0.2$ | 24. $0.592 \div 0.8$ |
| 25. $0.1404 \div 0.06$ | 26. $3.24 \div 0.002$ | 27. $0.968 \div 0.11$ | 28. $600 \div 0.5$ |
| 29. $0.007 \div 4$ | 30. $2640 \div 200$ | 31. $1100 \div 5.5$ | 32. $(11 + 2.4) \times 0.06$ |
| 33. $(0.4)^2 \div 0.2$ | 34. $77 \div 1000$ | 35. $(0.3)^2 \div 100$ | 36. $(0.1)^4 \div 0.01$ |
| 37. $\frac{92 \times 4.6}{2.3}$ | 38. $\frac{180 \times 4}{36}$ | 39. $\frac{0.55 \times 0.81}{4.5}$ | 40. $\frac{63 \times 600 \times 0.2}{360 \times 7}$ |

Exercise 2

- A maths teacher bought 40 calculators at \$8.20 each and a number of other calculators costing \$2.95 each. In all she spent \$387. How many of the cheaper calculators did she buy?
- At a temperature of 20°C the common amoeba reproduces by splitting in half every 24 hours. If we start with a single amoeba how many will there be after (a) 8 days, (b) 16 days?

You can find out about square numbers on page 5.

3. Copy and complete.

$$3^2 + 4^2 + 12^2 = 13^2$$

$$5^2 + 6^2 + 30^2 = 31^2$$

$$6^2 + 7^2 + \quad =$$

$$x^2 + \quad + \quad =$$

4. Find all the missing digits in these multiplications.

(a) $\begin{array}{r} 5* \\ 9\times \\ \hline **6 \end{array}$	(b) $\begin{array}{r} *7 \\ *\times \\ \hline 4*6 \end{array}$	(c) $\begin{array}{r} 5* \\ *\times \\ \hline 1*4 \end{array}$
--	--	--

5. Pages 6 and 27 are on the same (double) sheet of a newspaper. What are the page numbers on the opposite side of the sheet? How many pages are there in the newspaper altogether?

6. Use the numbers 1, 2, 3, 4, 5, 6, 7, 8, 9 once each and in their natural order to obtain an answer of 100. You may use only the operations +, -, ×, ÷.

7. The ruler below has eleven marks and can be used to measure lengths from one unit to twelve units.

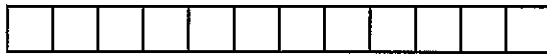

Design a ruler which can be used to measure all the lengths from one unit to twelve units but this time put the minimum possible number of marks on the ruler.

8. Each packet of washing powder carries a token and four tokens can be exchanged for a free packet. How many free packets will I receive if I buy 64 packets?

9. Put three different numbers in the circles so that when you add the numbers at the end of each line you always get a square number.

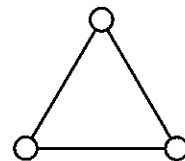

10. Put four different numbers in the circles so that when you add the numbers at the end of each line you always get a square number.

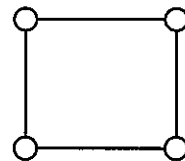

11. A group of friends share a bill for \$13.69 equally between them. How many were in the group?

Fractions

Common fractions are added or subtracted from one another directly only when they have a common denominator.

Example

Evaluate: (a) $\frac{3}{4} + \frac{2}{5}$ (b) $2\frac{3}{8} - 1\frac{5}{12}$ (c) $\frac{2}{5} \times \frac{6}{7}$ (d) $2\frac{2}{5} \div 6$

$$\begin{aligned} \text{(a)} \quad \frac{3}{4} + \frac{2}{5} &= \frac{15}{20} + \frac{8}{20} \\ &= \frac{23}{20} \\ &= 1\frac{3}{20} \end{aligned}$$

$$\begin{aligned} \text{(b)} \quad 2\frac{3}{8} - 1\frac{5}{12} &= \frac{19}{8} - \frac{17}{12} \\ &= \frac{57}{24} - \frac{34}{24} \\ &= \frac{23}{24} \end{aligned}$$

$$\text{(c)} \quad \frac{2}{5} \times \frac{6}{7} = \frac{12}{35}$$

$$\begin{aligned} \text{(d)} \quad 2\frac{2}{5} \div 6 &= \frac{12}{5} \div \frac{6}{1} \\ &= \frac{12}{5} \times \frac{1}{6} = \frac{2}{5} \end{aligned}$$

Remember
The order of operations follows the BODMAS rule:
Brackets then
powers of then
Divide then
Multiply then
Add then
Subtract

Exercise 3

Evaluate and simplify your answer.

- | | | | | |
|--------------------------------------|--|--|--|---|
| 1. $\frac{3}{4} + \frac{4}{5}$ | 2. $\frac{1}{3} + \frac{1}{8}$ | 3. $\frac{5}{6} + \frac{6}{9}$ | 4. $\frac{3}{4} - \frac{1}{3}$ | 5. $\frac{3}{5} - \frac{1}{3}$ |
| 6. $\frac{1}{2} - \frac{2}{5}$ | 7. $\frac{2}{3} \times \frac{4}{5}$ | 8. $\frac{1}{7} \times \frac{5}{6}$ | 9. $\frac{5}{8} \times \frac{12}{13}$ | 10. $\frac{1}{3} \div \frac{4}{5}$ |
| 11. $\frac{3}{4} \div \frac{1}{6}$ | 12. $\frac{5}{6} \div \frac{1}{2}$ | 13. $\frac{3}{8} + \frac{1}{5}$ | 14. $\frac{3}{8} \times \frac{1}{5}$ | 15. $\frac{3}{8} \div \frac{1}{5}$ |
| 16. $1\frac{3}{4} - \frac{2}{3}$ | 17. $1\frac{3}{4} \times \frac{2}{3}$ | 18. $1\frac{3}{4} \div \frac{2}{3}$ | 19. $3\frac{1}{2} + 2\frac{3}{5}$ | 20. $3\frac{1}{2} \times 2\frac{3}{5}$ |
| 21. $3\frac{1}{2} \div 2\frac{3}{5}$ | 22. $(\frac{3}{4} - \frac{2}{3}) \div \frac{3}{4}$ | 23. $(\frac{3}{5} + \frac{1}{3}) \times \frac{5}{7}$ | 24. $\frac{\frac{3}{8} - \frac{1}{5}}{\frac{7}{10} - \frac{2}{3}}$ | 25. $\frac{\frac{2}{3} + \frac{1}{5}}{\frac{3}{4} - \frac{1}{3}}$ |

26. Arrange the fractions in order of size:

(a) $\frac{7}{12}, \frac{1}{2}, \frac{2}{3}$ (b) $\frac{3}{4}, \frac{2}{3}, \frac{5}{6}$ (c) $\frac{1}{3}, \frac{17}{24}, \frac{5}{8}, \frac{3}{4}$ (d) $\frac{5}{6}, \frac{8}{9}, \frac{11}{12}$

27. Find the fraction which is mid-way between the two fractions given:

(a) $\frac{2}{5}, \frac{3}{5}$ (b) $\frac{5}{8}, \frac{7}{8}$ (c) $\frac{2}{3}, \frac{3}{4}$ (d) $\frac{1}{3}, \frac{4}{9}$ (e) $\frac{4}{15}, \frac{1}{3}$ (f) $\frac{3}{8}, \frac{11}{24}$

28. In the equation below all the asterisks stand for the same number. What is the number?

$$\left[\frac{*}{*} - \frac{*}{6} = \frac{*}{30} \right]$$

29. When it hatches from its egg, the shell of a certain crab is 1 cm across. When fully grown the shell is approximately 10 cm across. Each new shell is one-third bigger than the previous one. How many shells does a fully grown crab have during its life?

30. Glass A contains 100 ml of water and glass B contains 100 ml of wine.

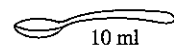

A 10 ml spoonful of wine is taken from glass B and mixed thoroughly with the water in glass A. A 10 ml spoonful of the mixture from A is returned to B. Is there now more wine in the water or more water in the wine?



Fractions and decimals

A decimal is simply a fraction expressed in tenths, hundredths etc.

Example

Change (a) $\frac{7}{8}$ to a decimal (b) 0.35 to a fraction. (c) $\frac{1}{3}$ to a decimal.

(a) $\frac{7}{8}$, divide 8 into 7 (b) $0.35 = \frac{35}{100} = \frac{7}{20}$ (c) $\frac{1}{3}$, divide 3 into 1

$$\frac{7}{8} = 0.875 \quad \begin{array}{r} 0.875 \\ 8 \overline{)7.000} \end{array}$$

$$\frac{1}{3} = 0.\dot{3} \text{ (0.3 recurring)}$$

$$\begin{array}{r} 0.3333 \\ 3 \overline{)1.0101000} \end{array}$$

Exercise 4

In questions 1 to 24, change the fractions to decimals.

- | | | | | | |
|--------------------|---------------------|---------------------|--------------------|--------------------|-----------------------|
| 1. $\frac{1}{4}$ | 2. $\frac{2}{5}$ | 3. $\frac{4}{5}$ | 4. $\frac{3}{4}$ | 5. $\frac{1}{2}$ | 6. $\frac{3}{8}$ |
| 7. $\frac{9}{10}$ | 8. $\frac{5}{8}$ | 9. $\frac{5}{12}$ | 10. $\frac{1}{6}$ | 11. $\frac{2}{3}$ | 12. $\frac{5}{6}$ |
| 13. $\frac{2}{7}$ | 14. $\frac{3}{7}$ | 15. $\frac{4}{9}$ | 16. $\frac{5}{11}$ | 17. $1\frac{1}{5}$ | 18. $2\frac{5}{8}$ |
| 19. $2\frac{1}{3}$ | 20. $1\frac{7}{10}$ | 21. $2\frac{3}{16}$ | 22. $2\frac{2}{7}$ | 23. $2\frac{6}{7}$ | 24. $3\frac{19}{100}$ |

In questions 25 to 40, change the decimals to fractions and simplify.

- | | | | |
|----------|----------|-----------|--------------|
| 25. 0.2 | 26. 0.7 | 27. 0.25 | 28. 0.45 |
| 29. 0.36 | 30. 0.52 | 31. 0.125 | 32. 0.625 |
| 33. 0.84 | 34. 2.35 | 35. 3.95 | 36. 1.05 |
| 37. 3.2 | 38. 0.27 | 39. 0.007 | 40. 0.000 11 |

Evaluate, giving the answer to 2 decimal places:

- | | | | |
|---------------------------------|--------------------------------------|-----------------------------|--|
| 41. $\frac{1}{4} + \frac{1}{3}$ | 42. $\frac{2}{3} + 0.75$ | 43. $\frac{8}{9} - 0.24$ | 44. $\frac{7}{8} + \frac{5}{9} + \frac{2}{11}$ |
| 45. $\frac{1}{3} \times 0.2$ | 46. $\frac{5}{8} \times \frac{1}{4}$ | 47. $\frac{8}{11} \div 0.2$ | 48. $(\frac{4}{7} - \frac{1}{3}) \div 0.4$ |

Arrange the numbers in order of size (smallest first)

- | | | | |
|--|--|----------------------------------|--|
| 49. $\frac{1}{3}$, 0.33, $\frac{4}{15}$ | 50. $\frac{2}{7}$, 0.3, $\frac{4}{9}$ | 51. 0.71, $\frac{7}{11}$, 0.705 | 52. $\frac{4}{13}$, 0.3, $\frac{5}{18}$ |
|--|--|----------------------------------|--|

1.2 Number facts and sequences

Number facts

- An *integer* is a whole number. e.g. 2, -3 ...
- A *prime* number is divisible only by itself and by one. e.g. 2, 3, 5, 7, 11, 13 ...
- The *multiples* of 12 are 12, 24, 36, 48 ...
- The *factors* of 12 are 1, 2, 3, 4, 6, 12.
- A *square number* is the result of multiplying a number by itself. e.g. $5 \times 5 = 25$ so 25 is a square number.
- A *cube number* is the result of multiplying a number by itself three times. e.g. $5 \times 5 \times 5 = 125$, so 125 is a cube number.

Exercise 5

- Which of the following are prime numbers?
3, 11, 15, 19, 21, 23, 27, 29, 31, 37, 39, 47, 51, 59, 61, 67, 72, 73, 87, 99
- Write down the first five multiples of the following numbers:
(a) 4 (b) 6 (c) 10 (d) 11 (e) 20
- Write down the first six multiples of 4 and of 6. What are the first two *common* multiples of 4 and 6? [i.e. multiples of both 4 and 6]
- Write down the first six multiples of 3 and of 5. What is the lowest common multiple of 3 and 5?
- Write down all the factors of the following:
(a) 6 (b) 9 (c) 10 (d) 15 (e) 24 (f) 32
- (a) Is 263 a prime number?
By how many numbers do you need to divide 263 so that you can find out?
(b) Is 527 a prime number?
(c) Suppose you used a computer to find out if 1147 was a prime number. Which numbers would you tell the computer to divide by?
- Make six prime numbers using the digits 1, 2, 3, 4, 5, 6, 7, 8, 9 once each.

Rational and irrational numbers

- A rational number can always be written exactly in the form $\frac{a}{b}$ where a and b are whole numbers.

$\frac{3}{7}$	$1\frac{1}{2} = \frac{3}{2}$	$5.14 = \frac{257}{50}$	$0.\dot{6} = \frac{2}{3}$
---------------	------------------------------	-------------------------	---------------------------

All these are rational numbers.

- An irrational number cannot be written in the form $\frac{a}{b}$.
 $\sqrt{2}$, $\sqrt{5}$, π , $\sqrt[3]{2}$ are all irrational numbers.
- In general \sqrt{n} is irrational unless n is a square number.

In this triangle the length of the hypotenuse is *exactly* $\sqrt{5}$.
On a calculator, $\sqrt{5} = 2.236068$. This value of $\sqrt{5}$ is *not* exact and is correct to only 6 decimal places.

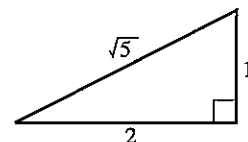
**Exercise 6**

- Which of the following numbers are rational?

$\frac{\pi}{2}$

$\sqrt{5}$

$(\sqrt{17})^2$

$\sqrt{3}$

3.14

$\frac{\sqrt{12}}{\sqrt{3}}$

π^2

$3^{-1} + 3^{-2}$

$7^{-\frac{1}{2}}$

$\frac{22}{7}$

$\sqrt{2} + 1$

$\sqrt{2.25}$

2. (a) Write down any rational number between 4 and 6.
- (b) Write down any irrational number between 4 and 6.
- (c) Find a rational number between $\sqrt{2}$ and $\sqrt{3}$.
- (d) Write down any rational number between π and $\sqrt{10}$.

3. (a) For each triangle use Pythagoras' theorem to calculate the length x .
- (b) For each triangle state whether the *perimeter* is rational or irrational.
- (c) For each triangle state whether the *area* is rational or irrational.
- (d) In which triangle is $\sin \theta$ an irrational number?

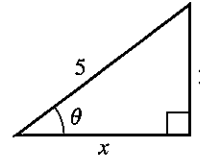

Triangle A

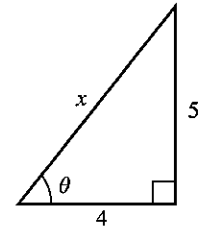

Triangle B

4. The diagram shows a circle of radius 3 cm drawn inside a square. Write down the exact value of the following and state whether the answer is rational or not:
 - (a) the circumference of the circle
 - (b) the diameter of the circle
 - (c) the area of the square
 - (d) the area of the circle
 - (e) the shaded area.

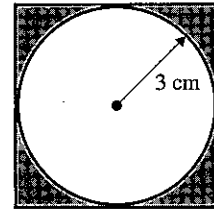

5. Think of two *irrational* numbers x and y such that $\frac{x}{y}$ is a *rational* number.
6. Explain the difference between a rational number and an irrational number.
7. (a) Is it possible to multiply a rational number and an irrational number to give an answer which is rational?
- (b) Is it possible to multiply two irrational numbers together to give a rational answer?
- (c) If either or both are possible, give an example.

Sequences

Exercise 7

Write down each sequence and find the next two numbers.

- | | | |
|-------------------|----------------------|---------------------|
| 1. 2, 6, 10, 14 | 2. 2, 9, 16, 23 | 3. 95, 87, 79, 71 |
| 4. 13, 8, 3, -2 | 5. 7, 9, 12, 16 | 6. 20, 17, 13, 8 |
| 7. 1, 2, 4, 7, 11 | 8. 1, 2, 4, 8 | 9. 55, 49, 42, 34 |
| 10. 10, 8, 5, 1 | 11. -18, -13, -9, -6 | 12. 120, 60, 30, 15 |
| 13. 27, 9, 3, 1 | 14. 162, 54, 18, 6 | 15. 2, 5, 11, 20 |
| 16. 1, 4, 20, 120 | 17. 2, 3, 1, 4, 0 | 18. 720, 120, 24, 6 |

We can describe a sequence by finding an expression for the n th term of the sequence.

- (a) For the sequence 4, 8, 12, 16, ...
The 10th term is $4 \times 10 = 40$.
The n th term is $4n$.
- (b) For the sequence (1×2) , (2×3) , (3×4) , (4×5) , ...
The 10th term is 10×11 .
The n th term is $n(n+1)$.
- (c) For the sequence 5, 7, 9, 11, ...
The common difference between each term is 2 so the expression will contain $2n$.
The n th term is $2n + 3$, by inspection.

Exercise 8

1. Write down each sequence and select the correct formula for the n th term from the list given.

$11n$ $10n$ $2n$ n^2 10^n $3n$ $100n$ n^3

- (a) 2, 4, 6, 8, ... (b) 10, 20, 30, 40, ...
(c) 3, 6, 9, 12, ... (d) 11, 22, 33, 44, ...
(e) 100, 200, 300, 400, ... (f) $1^2, 2^2, 3^2, 4^2, \dots$
(g) 10, 100, 1000, 10 000, ... (h) $1^3, 2^3, 3^3, 4^3, \dots$

2. Look at the sequence: 5, 8, 13, 20, ...
Decide which of the following is the correct expression for the n th term of the sequence.

$4n + 1$ $3n + 2$ $n^2 + 4$

In questions 3 to 10 find a formula for the n th term.

3. 5, 10, 15, 20, ... 4. 2, 4, 8, 16, 32, ... 5. (1×3) , (2×4) , (3×5) , ...
6. $\frac{1}{2}, \frac{2}{3}, \frac{3}{4}, \frac{4}{5}, \dots$ 7. 7, 14, 21, 28, ... 8. 1, 4, 9, 16, 25, ...
9. $\frac{5}{1^2}, \frac{5}{2^2}, \frac{5}{3^2}, \frac{5}{4^2}, \dots$ 10. $\frac{3}{1}, \frac{4}{2}, \frac{5}{3}, \frac{6}{4}, \dots$ 11. 3, 7, 11, 15, ...
12. 5, 7, 9, 11 13. 7, 5, 3, 1 14. -5, -1, 3, 7, ...

1.3 Approximations and estimation

Example

- (a) $7.8126 = 8$ to the nearest whole number
↑ This figure is '5 or more'.
- (b) $7.8126 = 7.81$ to three significant figures
↑ This figure is not '5 or more'.
- (c) $7.8126 = 7.813$ to three decimal places
↑ This figure is '5 or more'.
- (d) $0.078126 = 0.0781$ to three significant figures.
↑ 7 is the first significant figure.
- (e) $3596 = 3600$ to two significant figures.
↑ This figure is '5 or more'.

Exercise 9

Write the following numbers correct to:

(a) the nearest whole number (b) three significant figures (c) two decimal places

- | | | | | |
|-----------|------------|------------|------------|-----------|
| 1. 8.174 | 2. 19.617 | 3. 20.041 | 4. 0.81452 | 5. 311.14 |
| 6. 0.275 | 7. 0.00747 | 8. 15.62 | 9. 900.12 | 10. 3.555 |
| 11. 5.454 | 12. 20.961 | 13. 0.0851 | 14. 0.5151 | 15. 3.071 |

Write the following numbers correct to one decimal place.

- | | | | | | |
|----------|------------|------------|------------|------------|-----------|
| 16. 5.71 | 17. 0.7614 | 18. 11.241 | 19. 0.0614 | 20. 0.0081 | 21. 11.12 |
|----------|------------|------------|------------|------------|-----------|

Measurements and bounds*Measurement is approximate***Example 1**

A length of some cloth is measured for a dress. You might say the length is 145 cm to the nearest cm.

The actual length could be anything from 144.5 cm to 145.49999... cm using the normal convention which is to round up a figure of 5 or more. Clearly 145.49999... is effectively 145.5 and we say the *upper bound* is 145.5.

The *lower bound* is 144.5.

As an inequality we can write $144.5 \leq \text{length} < 145.5$

The upper limit often causes confusion. We use 145.5 as the upper bound simply because it is *inconvenient* to work with 145.49999...

Example 2

When measuring the length of a page in a book, you might say the length is 437 mm to the nearest mm.

In this case the actual length could be anywhere from 436.5 mm to 437.5 mm. We write 'length is between 436.5 mm and 437.5 mm'.

In both Examples 1 and 2, the measurement expressed to a given unit is in *possible error of half a unit*.

Example 3

- (a) If you say your weight is 57 kg to the nearest kg, you could actually weigh anything from 56.5 kg to 57.5 kg.
- (b) If your brother was weighed on more sensitive scales and the result was 57.2 kg, his actual weight could be from 57.15 kg to 57.25 kg.
- (c) The weight of a butterfly might be given as 0.032 g. The actual weight could be from 0.0315 g to 0.0325 g.

The unit is 1 so half a unit is 0.5

The unit is 0.1 so half a unit is 0.05

The unit is 0.001 so half a unit is 0.0005

Here are some further examples:

Measurement	Lower bound	Upper bound
The diameter of a CD is 12 cm to the nearest cm.	11.5 cm	12.5 cm
The mass of a coin is 6.2 g to the nearest 0.1 g.	6.15 g	6.25 g
The length of a fence is 330 m to the nearest 10 m.	325 m	335 m

Exercise 10

- In a DIY store the height of a door is given as 195 cm to the nearest cm. Write down the upper bound for the height of the door.
- A vet weighs a sick goat at 37 kg to the nearest kg. What is the least possible weight of the goat?
- A cook's weighing scales weigh to the nearest 0.1 kg. What is the upper bound for the weight of a chicken which she weighs at 3.2 kg?
- A surveyor using a laser beam device can measure distances to the nearest 0.1 m. What is the least possible length of a warehouse which he measures at 95.6 m?
- In the county sports Jill was timed at 28.6 s for the 200 m. What is the upper bound for the time she could have taken?
- Copy and complete the table.

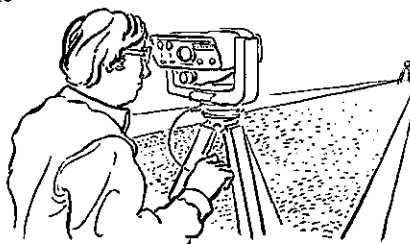

	Measurement	Lower bound	Upper bound
(a)	temperature in a fridge = 2 °C to the nearest degree		
(b)	mass of an acorn = 2.3 g to 1 d.p.		
(c)	length of telephone cable = 64 m to nearest m		
(d)	time taken to run 100 m = 13.6 s to nearest 0.1 s		

- The length of a telephone is measured as 193 mm, to the nearest mm. The length lies between:

A
B
C

192 and 194 mm
192.5 and 193.5 mm
188 and 198 mm



8. The weight of a labrador is 35 kg, to the nearest kg.
The weight lies between:

A	B	C
30 and 40 kg	34 and 36 kg	34.5 and 35.5 kg

9. Liz and Julie each measure a different worm and they both say that their worm is 11 cm long to the nearest cm.
(a) Does this mean that both worms are the same length?
(b) If not, what is the maximum possible difference in the length of the two worms?
10. To the nearest cm, the length l of a stapler is 12 cm. As an inequality we can write $11.5 \leq l < 12.5$.

For parts (a) to (j) you are given a measurement. Write the possible values using an inequality as above.

- | | |
|--------------------------------|--------------------------------------|
| (a) mass = 17 kg (2 s.f.) | (b) $d = 256$ km (3 s.f.) |
| (c) length = 2.4 m (1 d.p.) | (d) $m = 0.34$ grams (2 s.f.) |
| (e) $v = 2.04$ m/s (2 d.p.) | (f) $x = 12.0$ cm (1 d.p.) |
| (g) $T = 81.4$ °C (1 d.p.) | (h) $M = 0.3$ kg (1 s.f.) |
| (i) mass = 0.7 tonnes (1 s.f.) | (j) $n = 52\,000$ (nearest thousand) |

11. A card measuring 11.5 cm long (to the nearest 0.1 cm) is to be posted in an envelope which is 12 cm long (to the nearest cm).
Can you guarantee that the card will fit inside the envelope?
Explain your answer.



11.5 cm

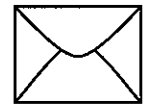

12 cm

Exercise 11

1. The sides of the triangle are measured correct to the nearest cm.
(a) Write down the upper bounds for the lengths of the three sides.
(b) Work out the maximum possible perimeter of the triangle.

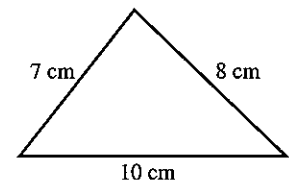

2. The dimensions of a photo are measured correct to the nearest cm.
Work out the minimum possible area of the photo.

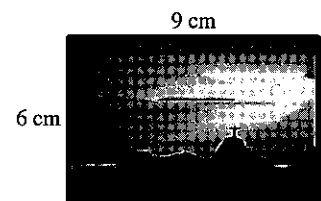

3. In this question the value of a is either exactly 4 or 5, and the value of b is either exactly 1 or 2. Work out:

- | | |
|--|--|
| (a) the maximum value of $a + b$ | (b) the minimum value of $a + b$ |
| (c) the maximum value of ab | (d) the maximum value of $a - b$ |
| (e) the minimum value of $a - b$ | (f) the maximum value of $\frac{a}{b}$ |
| (g) the minimum value of $\frac{a}{b}$ | (h) the maximum value of $a^2 - b^2$. |

4. If $p = 7$ cm and $q = 5$ cm, both to the nearest cm, find:
- the largest possible value of $p + q$
 - the smallest possible value of $p + q$
 - the largest possible value of $p - q$
 - the largest possible value of $\frac{p^2}{q}$.
5. If $a = 3.1$ and $b = 7.3$, correct to 1 decimal place, find the largest possible value of:
- $a + b$
 - $b - a$
6. If $x = 5$ and $y = 7$ to one significant figure, find the largest and smallest possible values of:
- $x + y$
 - $y - x$
 - $\frac{x}{y}$

7. In the diagram, ABCD and EFGH are rectangles with $AB = 10$ cm, $BC = 7$ cm, $EF = 7$ cm and $FG = 4$ cm, all figures accurate to the nearest cm. Find the largest possible value of the shaded area.

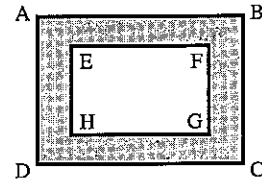

8. When a voltage V is applied to a resistance R the power consumed P is given by $P = \frac{V^2}{R}$. If you measure V as 12.2 and R as 2.6, correct to 1 d.p., calculate the smallest possible value of P .

Estimation

You should check that the answer to a calculation is 'about the right size'.

Example

Estimate the value of $\frac{57.2 \times 110}{2.146 \times 46.9}$, correct to one significant figure.

We have approximately, $\frac{50 \times 100}{2 \times 50} \approx 50$

On a calculator the value is 62.52 (to 4 significant figures)

Exercise 12

In this exercise there are 25 questions, each followed by three possible answers. Decide (by estimating) which answer is correct.

- | | |
|-----------------------|----------------------------|
| 1. 7.2×9.8 | [52.16, 98.36, 70.56] |
| 2. 2.03×58.6 | [118.958, 87.848, 141.116] |
| 3. 23.4×19.3 | [213.32, 301.52, 451.62] |
| 4. 313×107.6 | [3642.8, 4281.8, 33 678.8] |
| 5. 6.3×0.098 | [0.6174, 0.0622, 5.98] |
| 6. 1200×0.89 | [722, 1068, 131] |

- | | |
|--|----------------------------|
| 7. 0.21×93 | [41.23, 9.03, 19.53] |
| 8. 88.8×213 | [18 914.4, 1693.4, 1965.4] |
| 9. 0.04×968 | [38.72, 18.52, 95.12] |
| 10. 0.11×0.089 | [0.1069, 0.0959, 0.009 79] |
| 11. $13.92 \div 5.8$ | [0.52, 4.2, 2.4] |
| 12. $105.6 \div 9.6$ | [8.9, 11, 15] |
| 13. $8405 \div 205$ | [4.6, 402, 41] |
| 14. $881.1 \div 99$ | [4.5, 8.9, 88] |
| 15. $4.183 \div 0.89$ | [4.7, 48, 51] |
| 16. $6.72 \div 0.12$ | [6.32, 21.2, 56] |
| 17. $20.301 \div 1010$ | [0.0201, 0.211, 0.0021] |
| 18. $0.288 96 \div 0.0096$ | [312, 102.1, 30.1] |
| 19. $0.143 \div 0.11$ | [2.3, 1.3, 11.4] |
| 20. $159.65 \div 515$ | [0.11, 3.61, 0.31] |
| 21. $(5.6 - 0.21) \times 39$ | [389.21, 210.21, 20.51] |
| 22. $\frac{17.5 \times 42}{2.5}$ | [294, 504, 86] |
| 23. $(906 + 4.1) \times 0.31$ | [473.21, 282.131, 29.561] |
| 24. $\frac{543 + 472}{18.1 + 10.9}$ | [65, 35, 85] |
| 25. $\frac{112.2 \times 75.9}{6.9 \times 5.1}$ | [242, 20.4, 25.2] |

1.4 Standard form

When dealing with either very large or very small numbers, it is not convenient to write them out in full in the normal way. It is better to use standard form. Most calculators represent large and small numbers in this way.

The number $a \times 10^n$ is in standard form when $1 \leq a < 10$ and n is a positive or negative integer.

Example

Write the following numbers in standard form:

- (a) $2000 = 2 \times 1000 = 2 \times 10^3$
- (b) $150 = 1.5 \times 100 = 1.5 \times 10^2$
- (c) $0.0004 = 4 \times \frac{1}{10\,000} = 4 \times 10^{-4}$

Note

Most calculators show a display of 2^{03} . You must write 2×10^3 .

Exercise 13

Write the following numbers in standard form:

- | | | | | | |
|------------|-----------|---------------|----------|-------------|----------------|
| 1. 4000 | 2. 500 | 3. 70 000 | 4. 60 | 5. 2400 | 6. 380 |
| 7. 46 000 | 8. 46 | 9. 900 000 | 10. 2560 | 11. 0.007 | 12. 0.0004 |
| 13. 0.0035 | 14. 0.421 | 15. 0.000 055 | 16. 0.01 | 17. 564 000 | 18. 19 million |

19. The population of China is estimated at 1100 000 000. Write this in standard form.
20. A hydrogen atom weighs 0.000 000 000 000 000 000 001 67 grams. Write this weight in standard form.
21. The area of the surface of the Earth is about 510 000 000 km². Express this in standard form.
22. An atom is 0.000 000 000 25 cm in diameter. Write this in standard form.
23. Avogadro's number is 602 300 000 000 000 000 000. Express this in standard form.
24. The speed of light is 300 000 km/s. Express this speed in cm/s in standard form.
25. A very rich oil sheikh leaves his fortune of $\$3.6 \times 10^8$ to be divided between his 100 children. How much does each child receive? Give the answer in standard form.

Hint
1 km = 1000 m
1 m = 100 cm

Example

Work out $1500 \times 8\,000\,000$

$$\begin{aligned} 1500 \times 8\,000\,000 &= (1.5 \times 10^3) \times (8 \times 10^6) \\ &= 12 \times 10^9 \\ &= 1.2 \times 10^{10} \end{aligned}$$

Notice that we multiply the numbers and the powers of 10 separately.

Exercise 14

In questions 1 to 12 give the answer in standard form.

- | | | | |
|-------------------------|--------------------------|---------------------------|--------------------------------|
| 1. 5000×3000 | 2. $60\,000 \times 5000$ | 3. $0.000\,07 \times 400$ | 4. $0.000\,7 \times 0.000\,01$ |
| 5. $8000 \div 0.004$ | 6. $(0.002)^2$ | 7. 150×0.0006 | 8. $0.000\,033 \div 500$ |
| 9. $0.007 \div 20\,000$ | 10. $(0.0001)^4$ | 11. $(2000)^3$ | 12. $0.005\,92 \div 8000$ |
13. If $a = 512 \times 10^2$ $b = 0.478 \times 10^6$ $c = 0.0049 \times 10^7$
arrange a , b and c in order of size (smallest first).
14. If the number 2.74×10^{15} is written out in full, how many zeros follow the 4?
15. If the number 7.31×10^{-17} is written out in full, how many zeros would there be between the decimal point and the first significant figure?
16. If $x = 2 \times 10^5$ and $y = 3 \times 10^{-3}$ correct to one significant figure, find the greatest and least possible values of:
- (i) xy (ii) $\frac{x}{y}$

Remember
The limits of accuracy of 2 to one significant figure are 1.5 to 2.5.



17. Oil flows through a pipe at a rate of $40 \text{ m}^3/\text{s}$. How long will it take to fill a tank of volume $1.2 \times 10^5 \text{ m}^3$?
18. Given that $L = 2\sqrt{\frac{a}{k}}$, find the value of L in standard form when $a = 4.5 \times 10^{12}$ and $k = 5 \times 10^7$.
19. (a) The number 10 to the power 100 (10 000 sexdecillion) is called a 'Googol'. If it takes $\frac{1}{5}$ second to write a zero and $\frac{1}{10}$ second to write a 'one', how long would it take to write the number 100 'Googols' in full?
- (b) The number 10 to the power of a 'Googol' is called a 'Googolplex'. Using the same speed of writing, how long in years would it take to write 1 'Googolplex' in full? You may assume that your pen has enough ink.

1.5 Ratio and proportion

The word 'ratio' is used to describe a fraction. If the *ratio* of a boy's height to his father's height is 4:5, then he is $\frac{4}{5}$ as tall as his father.

Example 1

Change the ratio 2:5 into the form

- | | |
|---------------------------|---------------------------|
| (a) $1:n$ | (b) $m:1$ |
| (a) $2:5 = 1:\frac{5}{2}$ | (b) $2:5 = \frac{2}{5}:1$ |
| $= 1:2.5$ | $= 0.4:1$ |

Example 2

Divide \$60 between two people A and B in the ratio 5:7.

Consider \$60 as 12 equal parts (i.e. $5 + 7$). Then A receives 5 parts and B receives 7 parts.

- \therefore A receives $\frac{5}{12}$ of \$60 = \$25
B receives $\frac{7}{12}$ of \$60 = \$35

Example 3

Divide 200 kg in the ratio 1:3:4.

The parts are $\frac{1}{8}$, $\frac{3}{8}$ and $\frac{4}{8}$ (of 200 kg). i.e. 25 kg, 75 kg and 100 kg.

Exercise 15

In questions 1 to 8 express the ratios in the form $1:n$.

- | | | | |
|--------|---------|-----------|-----------|
| 1. 2:6 | 2. 5:30 | 3. 2:100 | 4. 5:8 |
| 5. 4:3 | 6. 8:3 | 7. 22:550 | 8. 45:360 |

In questions 9 to 12 express the ratios in the form $n:1$.

- | | | | |
|---------|---------|---------|-----------|
| 9. 12:5 | 10. 5:2 | 11. 4:5 | 12. 2:100 |
|---------|---------|---------|-----------|

In questions 13 to 18 divide the quantity in the ratio given.

13. \$40; (3 : 5) 14. \$120; (3 : 7) 15. 250 m; (14 : 11)
 16. \$117; (2 : 3 : 8) 17. 180 kg; (1 : 5 : 6) 18. 184 minutes; (2 : 3 : 3)
19. When \$143 is divided in the ratio 2 : 4 : 5, what is the difference between the largest share and the smallest share?
20. Divide 180 kg in the ratio 1 : 2 : 3 : 4.
21. Divide \$4000 in the ratio 2 : 5 : 5 : 8.
22. If $\frac{5}{8}$ of the children in a school are boys, what is the ratio of boys to girls?
23. A man and a woman share a bingo prize of \$1000 between them in the ratio 1 : 4. The woman shares her part between herself, her mother and her daughter in the ratio 2 : 1 : 1. How much does her daughter receive?
24. A man and his wife share a sum of money in the ratio 3 : 2. If the sum of money is doubled, in what ratio should they divide it so that the man still receives the same amount?
25. In a herd of x cattle, the ratio of the number of bulls to cows is 1 : 6. Find the number of bulls in the herd in terms of x .
26. If $x : 3 = 12 : x$, calculate the positive value of x .
27. If $y : 18 = 8 : y$, calculate the positive value of y .
28. \$400 is divided between Ann, Beyoncé and Carol so that Ann has twice as much as Beyoncé and Beyoncé has three times as much as Carol. How much does Beyoncé receive?
29. A cake weighing 550 g has three ingredients: flour, sugar and raisins. There is twice as much flour as sugar and one and a half times as much sugar as raisins. How much flour is there?
30. A brother and sister share out their collection of 5000 stamps in the ratio 5 : 3. The brother then shares his stamps with two friends in the ratio 3 : 1 : 1, keeping most for himself. How many stamps do each of his friends receive?

Proportion

The majority of problems where proportion is involved are usually solved by finding the value of a unit quantity.

Example 1

If a wire of length 2 metres costs \$10, find the cost of a wire of length 35 cm.

200 cm costs 1000 cents

$$\therefore 1 \text{ cm costs } \frac{1000}{200} \text{ cents} = 5 \text{ cents}$$

$$\therefore 35 \text{ cm costs } 5 \times 35 \text{ cents} = 175 \text{ cents} \\ = \$1.75$$

Example 2

Eight men can dig a trench in 4 hours. How long will it take five men to dig the same size trench?

8 men take 4 hours

1 man would take 32 hours

5 men would take $\frac{32}{5}$ hours = 6 hours 24 minutes.

Exercise 16

1. Five cans of beer cost \$1.20. Find the cost of seven cans.
2. A man earns \$140 in a 5-day week. What is his pay for 3 days?
3. Three men build a wall in 10 days. How long would it take five men?
4. Nine milk bottles contain $4\frac{1}{2}$ litres of milk between them.
How much do five bottles hold?
5. A car uses 10 litres of petrol in 75 km. How far will it go on 8 litres?
6. A wire 11 cm long has a mass of 187 g. What is the mass of 7 cm of this wire?
7. A shopkeeper can buy 36 toys for £20.52. What will he pay for 120 toys?
8. A ship has sufficient food to supply 600 passengers for 3 weeks.
How long would the food last for 800 people?
9. The cost of a phone call lasting 3 minutes 30 seconds was 52.5 cents.
At this rate, what was the cost of a call lasting 5 minutes 20 seconds?
10. 80 machines can produce 4800 identical pens in 5 hours.
At this rate
 - (a) how many pens would one machine produce in one hour?
 - (b) how many pens would 25 machines produce in 7 hours?
11. Three men can build a wall in 10 hours. How many men would be needed to build the wall in $7\frac{1}{2}$ hours?
12. If it takes 6 men 4 days to dig a hole 3 feet deep, how long will it take 10 men to dig a hole 7 feet deep?
13. Find the cost of 1 km of pipe at 7 cents for every 40 cm.
14. A wheel turns through 90 revolutions per minute.
How many degrees does it turn through in 1 second?
15. Find the cost of 20 grams of lead at \$60 per kilogram.

Remember
1 kg = 1000 g

16. The height of an office building is 623 feet. Express this height to the nearest metre using $1 \text{ m} = 3.281 \text{ feet}$.
17. A floor is covered by 800 tiles measuring 10 cm square.
How many square tiles of side 8 cm would be needed to cover the same floor?

18. A battery has enough energy to operate eight toy bears for 21 hours. For how long could the battery operate 15 toy bears?
19. An engine has enough fuel to operate at full power for 20 minutes. For how long could the engine operate at 35% of full power?
20. A large drum, when full, contains 260 kg of oil of density 0.9 g/cm^3 . What weight of petrol, of density 0.84 g/cm^3 , can be contained in the drum?
21. A wall can be built by 6 men working 8 hours per day in 5 days. How many days will it take 4 men to build the wall if they work only 5 hours per day?

Foreign exchange

Money is changed from one currency into another using the method of proportion.

Exchange rate for US dollars (\$):

Country	Rate of exchange
Argentina (pesos)	1.01 ARPO = \$1
Kuwait (dinar)	0.30 KD = \$1
S Arabia (rial)	3.75 SR = \$1
UK (pounds)	£0.63 = \$1
Euro (euros)	€0.93 = \$1

Example

Convert: (a) \$22.50 to dinars (b) €300 to dollars.

$$(a) \quad \$1 = 0.30 \text{ dinars (KD)} \quad (b) \quad €0.93 = \$1$$

$$\text{so } \$22.50 = 0.30 \times 22.50 \text{ KD} \quad \text{so } €1 = \frac{1}{0.93}$$

$$= 6.75 \text{ KD}$$

$$\text{so } €300 = \$\frac{1}{0.93} \times 300$$

$$= \$322.58$$

Exercise 17

Give your answers correct to two decimal places. Use the exchange rates given in the table.

- Change the amount of dollars into the foreign currency stated.

(a) \$20 [euros]	(b) \$70 [pounds]	(c) \$200 [ARPO]
(d) \$1.50 [euros]	(e) \$2.30 [rials]	(f) 90c [dinars]
- Change the amount of foreign currency into dollars.

(a) €500	(b) £2500	(c) €7.5
(d) 900 dinars	(e) 125.24 ARPO	(f) 750 SR

3. A CD costs £9.50 in Britain and \$9.70 in the United States. How much cheaper, in British money, is the CD when bought in the USA?
4. A bottle of Cointreau costs €20.46 in Spain and £12.60 in the UK. Which is the cheaper in dollars, and by how much?
5. The EEC 'Butter Mountain' was estimated in 2004 to be costing €32 860 per day to maintain the storage facilities. How much is this in US dollars?
6. A Jaguar XJS is sold in several countries at the prices given below.
- | | |
|---------|----------|
| Britain | £15 000 |
| France | €29 490 |
| USA | \$25 882 |

Write out in order a list of the prices converted into pounds.

7. An Irish gentleman on holiday in Germany finds that his wallet contains \$700. If he changes the money at a bank how many euros will he receive?

Map scales

You can use proportion to work out map scales. First you need to know these metric equivalents:

1 km = 1000 m	km means kilometre
1 m = 100 cm	m means metre
1 cm = 10 mm	cm means centimetre
	mm means millimetre

Example

A map is drawn to a scale of 1 to 50 000. Calculate:

- (a) the length of a road which appears as 3 cm long on the map.
 (b) the length on the map of a lake which is 10 km long.

- (a) 1 cm on the map is equivalent to 50 000 cm on the Earth.

$$\begin{aligned} \therefore 1 \text{ cm} &\equiv 50\,000 \text{ cm} \\ \therefore 1 \text{ cm} &\equiv 500 \text{ m} \\ \therefore 1 \text{ cm} &\equiv 0.5 \text{ km} \end{aligned}$$

$$\text{so } 3 \text{ cm} \equiv 3 \times 0.5 \text{ km} = 1.5 \text{ km.}$$

The road is 1.5 km long.

- (b) 0.5 km \equiv 1 cm

$$\begin{aligned} \therefore 1 \text{ km} &\equiv 2 \text{ cm} \\ \therefore 10 \text{ km} &\equiv 2 \times 10 \text{ cm} \\ &= 20 \text{ cm} \end{aligned}$$

The lake appears 20 cm long on the map.

Exercise 18

- Find the actual length represented on a drawing by

(a) 14 cm	(b) 3.2 cm
(c) 0.71 cm	(d) 21.7 cm

 when the scale is 1 cm to 5 m.
- Find the length on a drawing that represents

(a) 50 m	(b) 35 m
(c) 7.2 m	(d) 28.6 m

 when the scale is 1 cm to 10 m.
- If the scale is 1 : 10 000, what length will 45 cm on the map represent:

(a) in cm;	(b) in m;	(c) in km?
------------	-----------	------------
- On a map of scale 1 : 100 000, the distance between Tower Bridge and Hammersmith Bridge is 12.3 cm. What is the actual distance in km?
- On a map of scale 1 : 15 000, the distance between Buckingham Palace and Brixton Underground Station is 31.4 cm. What is the actual distance in km?
- If the scale of a map is 1 : 10 000, what will be the length on this map of a road which is 5 km long?
- The distance from Hertford to St Albans is 32 km. How far apart will they be on a map of scale 1 : 50 000?
- The 17th hole at the famous St Andrews golf course is 420 m in length. How long will it appear on a plan of the course of scale 1 : 8000?

An area involves two dimensions multiplied together and hence the scale is multiplied *twice*.

For example, if the linear scale is $\frac{1}{100}$, then the area scale is $\frac{1}{100} \times \frac{1}{100} = \frac{1}{10\,000}$.

You can use a diagram to help:

If a scale is 1 : 50 000
then 2 cm \equiv 1 km

An area of 6 cm² can be thought of as:

3 cm	2 cm
6 cm ²	

so the equivalent area using the scale is:

1.5 km	1 km
1.5 km ²	



Exercise 19

1. The scale of a map is 1 : 1000. What are the actual dimensions of a rectangle which appears as 4 cm by 3 cm on the map? What is the area on the map in cm^2 ? What is the actual area in m^2 ?
2. The scale of a map is 1 : 100. What area does 1 cm^2 on the map represent? What area does 6 cm^2 represent?
3. The scale of a map is 1 : 20 000. What area does 8 cm^2 represent?
4. The scale of a map is 1 : 1000. What is the area, in cm^2 , on the map of a lake of area 5000 m^2 ?
5. The scale of a map is 1 cm to 5 km. A farm is represented by a rectangle measuring 1.5 cm by 4 cm. What is the actual area of the farm?
6. On a map of scale 1 cm to 250 m the area of a car park is 3 cm^2 . What is the actual area of the car park in hectares? (1 hectare = $10\,000 \text{ m}^2$).
7. The area of the playing surface at Wembley Stadium is $\frac{3}{5}$ of a hectare. What area will it occupy on a plan drawn to a scale of 1 : 500?
8. On a map of scale 1 : 20 000 the area of a forest is 50 cm^2 . On another map the area of the forest is 8 cm^2 . Find the scale of the second map.

1.6 Percentages

Percentages are simply a convenient way of expressing fractions or decimals. '50% of \$60' means $\frac{50}{100}$ of \$60, or more simply $\frac{1}{2}$ of \$60. Percentages are used very frequently in everyday life and are misunderstood by a large number of people. What are the implications if 'inflation falls from 10% to 8%'? Does this mean prices will fall?

Example

- (a) Change 80% to a fraction.
- (b) Change $\frac{3}{8}$ to a percentage.
- (c) Change 8% to a decimal.

$$(a) \quad 80\% = \frac{80}{100} = \frac{4}{5}$$

$$(b) \quad \frac{3}{8} = \left(\frac{3}{8} \times \frac{100}{1}\right)\% = 37\frac{1}{2}\%$$

$$(c) \quad 8\% = \frac{8}{100} = 0.08$$

Exercise 20

1. Change to fractions:

- (a) 60% (b) 24% (c) 35% (d) 2%

2. Change to percentages:

- (a)
- $\frac{1}{4}$
- (b)
- $\frac{1}{10}$
- (c)
- $\frac{7}{8}$
-
- (d)
- $\frac{1}{3}$
- (e) 0.72 (f) 0.31

3. Change to decimals:

- (a) 36% (b) 28% (c) 7%
-
- (d) 13.4% (e)
- $\frac{3}{5}$
- (f)
- $\frac{7}{8}$

4. Arrange in order of size (smallest first):

- (a)
- $\frac{1}{2}$
- ; 45%; 0.6 (b) 0.38;
- $\frac{6}{16}$
- ; 4%
-
- (c) 0.111; 11%;
- $\frac{1}{9}$
- (d) 32%; 0.3;
- $\frac{1}{3}$

5. The following are marks obtained in various tests. Convert them to percentages.

- (a) 17 out of 20 (b) 31 out of 40 (c) 19 out of 80
-
- (d) 112 out of 200 (e)
- $2\frac{1}{2}$
- out of 25 (f)
- $7\frac{1}{2}$
- out of 20

Example 1

A car costing \$400 is reduced in price by 10%. Find the new price.

$$10\% \text{ of } \$2400 = \frac{10}{100} \times \frac{2400}{1}$$

$$= \$240$$

$$\text{New price of car} = \$(2400 - 240)$$

$$= \$2160$$

Example 2After a price increase of 10% a television set costs \$286.
What was the price before the increase?

The price before the increase is 100%.

$$\therefore 110\% \text{ of old price} = \$286$$

$$\therefore 1\% \text{ of old price} = \$\frac{286}{110}$$

$$\therefore 100\% \text{ of old price} = \$\frac{286}{110} \times \frac{100}{1}$$

$$\text{Old price of TV} = \$260$$

**Exercise 21**

1. Calculate:
 - (a) 30% of \$50
 - (b) 45% of 2000 kg
 - (c) 4% of \$70
 - (d) 2.5% of 5000 people
2. In a sale, a jacket costing \$40 is reduced by 20%. What is the sale price?
3. The charge for a telephone call costing 12 cents is increased by 10%. What is the new charge?
4. In peeling potatoes 4% of the mass of the potatoes is lost as 'peel'. How much is *left* for use from a bag containing 55 kg?
5. Work, to the nearest cent:
 - (a) 6.4% of \$15.95
 - (b) 11.2% of \$192.66
 - (c) 8.6% of \$25.84
 - (d) 2.9% of \$18.18
6. Find the total bill:
5 golf clubs at \$18.65 each
60 golf balls at \$16.50 per dozen
1 bag at \$35.80
Sales tax at 15% is added to the total cost.
7. In 2000 a club has 250 members who each pay \$95 annual subscription. In 2001 the membership increases by 4% and the annual subscription is increased by 6%. What is the total income from subscriptions in 2001?
8. In 1999 the prison population was 48 700 men and 1600 women. What percentage of the total prison population were men?
9. In 1999 there were 21 280 000 licensed vehicles on the road. Of these, 16 486 000 were private cars. What percentage of the licensed vehicles were private cars?
10. A quarterly telephone bill consists of \$19.15 rental plus 4.7 cents for each dialled unit. Sales tax is added at 15%. What is the total bill for Mrs Jones who used 915 dialled units?
11. Hassan thinks his goldfish got chickenpox. He lost 70% of his collection of goldfish. If he has 60 survivors, how many did he have originally?
12. The average attendance at Parma football club fell by 7% in 1999. If 2030 fewer people went to matches in 1999, how many went in 1998?
13. When heated an iron bar expands by 0.2%. If the increase in length is 1 cm, what is the original length of the bar?
14. In the last two weeks of a sale, prices are reduced first by 30% and then by a *further* 40% of the new price. What is the final sale price of a shirt which originally cost \$15?

15. During a Grand Prix car race, the tyres on a car are reduced in weight by 3%. If they weigh 388 kg at the end of the race, how much did they weigh at the start?
16. Over a period of 6 months, a colony of rabbits increases in number by 25% and then by a further 30%. If there were originally 200 rabbits in the colony how many were there at the end?
17. A television costs \$270.25 including 15% sales tax. How much of the cost is tax?
18. The cash price for a car was \$7640. Mr Khan bought the car on the following hire purchase terms: 'A deposit of 20% of the cash price and 36 monthly payments of \$191.60'. Calculate the total amount Mr Khan paid.

Percentage increase or decrease

In the next exercise use the formulae:

$$\text{Percentage profit} = \frac{\text{Actual profit}}{\text{Original price}} \times \frac{100}{1}$$

$$\text{Percentage loss} = \frac{\text{Actual loss}}{\text{Original price}} \times \frac{100}{1}$$

Example 1

A radio is bought for \$16 and sold for \$20. What is the percentage profit?

$$\text{Actual profit} = \$4$$

$$\therefore \text{Percentage profit} = \frac{4}{16} \times \frac{100}{1} = 25\%$$

The radio is sold at a 25% profit.

Example 2

A car is sold for \$2280, at a loss of 5% on the cost price. Find the cost price.

Do *not* calculate 5% of \$2280!

The loss is 5% of the cost price.

$$\therefore 95\% \text{ of cost price} = \$2280$$

$$1\% \text{ of cost price} = \$ \frac{2280}{95}$$

$$\therefore 100\% \text{ of cost price} = \$ \frac{2280}{95} \times \frac{100}{1}$$

$$\text{Cost price} = \$2400$$

Exercise 22

- The first figure is the cost price and the second figure is the selling price. Calculate the percentage profit or loss in each case.

(a) \$20, \$25	(b) \$400, \$500	(c) \$60, \$54
(d) \$9000, \$10 800	(e) \$460, \$598	(f) \$512, \$550.40
(g) \$45, \$39.60	(h) 50¢, 23¢	
- A car dealer buys a car for \$500, gives it a clean, and then sells it for \$640. What is the percentage profit?
- A damaged carpet which cost \$180 when new, is sold for \$100. What is the percentage loss?
- During the first four weeks of her life, a baby girl increases her weight from 3.2 kg to 4.7 kg. What percentage increase does this represent? (Give your answer to 3 sig. fig.)
- When sales tax is added to the cost of a car tyre, its price increases from \$16.50 to \$18.48. What is the rate at which sales tax is charged?
- In order to increase sales, the price of a Concorde airliner is reduced from £30 000 000 to £28 400 000. What percentage reduction is this?
- Find the *cost* price of the following:

(a) selling price \$55, profit 10%	(b) selling price \$558, profit 24%
(c) selling price \$680, loss 15%	(d) selling price \$11.78, loss 5%
- An oven is sold for \$600, thereby making a profit of 20%, on the cost price. What was the cost price?
- A pair of jeans is sold for \$15, thereby making a profit of 25% on the cost price. What was the cost price?
- A book is sold for \$5.40, at a profit of 8% on the cost price. What was the cost price?
- A can of worms is sold for 48¢, incurring a loss of 20%. What was the cost price?
- A car, which failed its safety test, was sold for \$1430, thereby making a loss of 35% on the cost price. What was the cost price?
- If an employer reduces the working week from 40 hours to 35 hours, with no loss of weekly pay, calculate the percentage increase in the hourly rate of pay.
- The rental for a television set changed from \$80 per year to \$8 per month. What is the percentage increase in the yearly rental?
- A greengrocer sells a melon at a profit of $37\frac{1}{2}\%$ on the price he pays for it. What is the ratio of the cost price to the selling price?
- Given that $G = ab$, find the percentage increase in G when both a and b increase by 10%.
- Given that $T = \frac{kx}{y}$, find the percentage increase in T when k , x and y all increase by 20%.

Hint
 ¢ is the symbol for cents.
 $100¢ = \$1$

Simple interest

When a sum of money $\$P$ is invested for T years at $R\%$ interest per annum (each year), then the interest gained I is given by:

$$I = \frac{P \times R \times T}{100}$$

This is known as simple interest.

Example

Joel invests $\$400$ for 6 months at 5% .

Work out the simple interest gained.

$$P = \$400 \quad R = 5 \quad T = 0.5 \quad (\text{6 months is half a year})$$

$$\text{so } I = \frac{400 \times 5 \times 0.5}{100}$$

$$I = \$10$$

Exercise 23

1. Calculate:

- the simple interest on $\$1200$ for 3 years at 6% per annum
- the simple interest on $\$700$ at 8.25% per annum for 2 years
- the length of time for $\$5000$ to earn $\$1000$ if invested at 10% per annum
- the length of time for $\$400$ to earn $\$160$ if invested at 8% per annum.

2. Khalid invests $\$6750$ at 8.5% per annum. How much interest has he earned and what is the total amount in his account after 4 years?

3. Shareen invests $\$10\,800$. After 4 years she has earned $\$3240$ in interest. At what annual rate of interest did she invest her money?

Compound interest

Suppose a bank pays a fixed interest of 10% on money in deposit accounts. A man puts $\pounds 500$ in the bank.

After one year he has

$$500 + 10\% \text{ of } 500 = \pounds 550$$

After two years he has

$$550 + 10\% \text{ of } 550 = \pounds 605$$

$$[\text{Check that this is } 1 \cdot 10^2 \times 500]$$

After three years he has

$$605 + 10\% \text{ of } 605 = \pounds 665.50$$

$$[\text{Check that this is } 1 \cdot 10^3 \times 500]$$

In general after n years the money in the bank will be $\pounds(1 \cdot 10^n \times 500)$

\pounds is the symbol for UK pounds sterling.

**Exercise 24**

1. A bank pays interest of 9% on money in deposit accounts. Mrs Wells puts £2000 in the bank. How much has she after (a) one year, (b) two years, (c) three years?
2. A bank pays interest of 11%. Mr Olsen puts £5000 in the bank. How much has he after (a) one year, (b) three years, (c) five years?
3. A computer operator is paid £10 000 a year. Assuming her pay is increased by 7% each year, what will her salary be in four years time?
4. Mrs Bergkamp's salary in 2001 is £30 000 per year. Every year her salary is increased by 5%.
In 2002 her salary will be $30\,000 \times 1.05 = £31\,500$
In 2003 her salary will be $30\,000 \times 1.05 \times 1.05 = £33\,075$
In 2004 her salary will be $30\,000 \times 1.05 \times 1.05 \times 1.05 = £34\,728.75$
And so on.
(a) What will her salary be in 2005?
(b) What will her salary be in 2007?
5. The price of a house was £90 000 in 1998. At the end of each year the price is increased by 6%.
(a) Find the price of the house after 1 year.
(b) Find the price of the house after 3 years.
(c) Find the price of the house after 10 years.
6. Assuming an average inflation rate of 8%, work out the probable cost of the following items in 10 years:
(a) car £6500
(b) T.V. £340
(c) house £50 000
7. A new car is valued at £15 000. At the end of each year its value is reduced by 15% of its value at the start of the year. What will it be worth after 3 years?
8. The population of an island increases by 10% each year. After how many years will the original population be doubled?
9. A bank pays interest of 11% on £6000 in a deposit account. After how many years will the money have trebled?
10. A tree grows in height by 21% per year. It is 2 m tall after one year. After how many more years will the tree be over 20 m tall?
11. Which is the better investment over ten years:
£20 000 at 12% compound interest
or £30 000 at 8% compound interest?

1.7 Speed, distance and time

Calculations involving these three quantities are simpler when the speed is *constant*. The formulae connecting the quantities are as follows:

(a) distance = speed \times time

(b) speed = $\frac{\text{distance}}{\text{time}}$

(c) time = $\frac{\text{distance}}{\text{speed}}$

A helpful way of remembering these formulae is to write the letters D , S and T in a triangle,

thus:

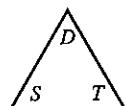

to find D , cover D and we have ST

to find S , cover S and we have $\frac{D}{T}$

to find T , cover T and we have $\frac{D}{S}$

Great care must be taken with the units in these questions.

Example 1

A man is running at a speed of 8 km/h for a distance of 5200 metres. Find the time taken in minutes.

$$5200 \text{ metres} = 5.2 \text{ km}$$

$$\begin{aligned} \text{time taken in hours} &= \left(\frac{D}{S}\right) = \frac{5.2}{8} \\ &= 0.65 \text{ hours} \end{aligned}$$

$$\begin{aligned} \text{time taken in minutes} &= 0.65 \times 60 \\ &= 39 \text{ minutes} \end{aligned}$$

Example 2

Change the units of a speed of 54 km/h into metres per second.

$$\begin{aligned} 54 \text{ km/hour} &= 54\,000 \text{ metres/hour} \\ &= \frac{54\,000}{60} \text{ metres/minute} \\ &= \frac{54\,000}{60 \times 60} \text{ metres/second} \\ &= 15 \text{ m/s} \end{aligned}$$

**Exercise 25**

1. Find the time taken for the following journeys:
 - (a) 100 km at a speed of 40 km/h
 - (b) 250 miles at a speed of 80 miles per hour
 - (c) 15 metres at a speed of 20 cm/s (answer in seconds)
 - (d) 10^4 metres at a speed of 2.5 km/h

2. Change the units of the following speeds as indicated:
 - (a) 72 km/h into m/s
 - (b) 108 km/h into m/s
 - (c) 300 km/h into m/s
 - (d) 30 m/s into km/h
 - (e) 22 m/s into km/h
 - (f) 0.012 m/s into cm/s
 - (g) 9000 cm/s into m/s
 - (h) 600 miles/day into miles per hour
 - (i) 2592 miles/day into miles per second

3. Find the speeds of the bodies which move as follows:
 - (a) a distance of 600 km in 8 hours
 - (b) a distance of 31.64 km in 7 hours
 - (c) a distance of 136.8 m in 18 seconds
 - (d) a distance of 4×10^4 m in 10^{-2} seconds
 - (e) a distance of 5×10^5 cm in 2×10^{-3} seconds
 - (f) a distance of 10^8 mm in 30 minutes (in km/h)
 - (g) a distance of 500 m in 10 minutes (in km/h)

4. Find the distance travelled (in metres) in the following:
 - (a) at a speed of 55 km/h for 2 hours
 - (b) at a speed of 40 km/h for $\frac{1}{4}$ hour
 - (c) at a speed of 338.4 km/h for 10 minutes
 - (d) at a speed of 15 m/s for 5 minutes
 - (e) at a speed of 14 m/s for 1 hour
 - (f) at a speed of 4×10^3 m/s for 2×10^{-2} seconds
 - (g) at a speed of 8×10^5 cm/s for 2 minutes

5. A car travels 60 km at 30 km/h and then a further 180 km at 160 km/h. Find:
 - (a) the total time taken
 - (b) the average speed for the whole journey.

6. A cyclist travels 25 kilometres at 20 km/h and then a further 80 kilometres at 25 km/h. Find:
 - (a) the total time taken
 - (b) the average speed for the whole journey.

7. A swallow flies at a speed of 50 km/h for 3 hours and then at a speed of 40 km/h for a further 2 hours. Find the average speed for the whole journey.

8. A runner ran two laps around a 400 m track. She completed the first lap in 50 seconds and then decreased her speed by 5% for the second lap. Find:
 - (a) her speed on the first lap
 - (b) her speed on the second lap
 - (c) her total time for the two laps
 - (d) her average speed for the two laps.
9. The airliner Concorde flies 2000 km at a speed of 1600 km/h and then returns due to bad weather at a speed of 1000 km/h. Find the average speed for the whole trip.
10. A train travels from A to B, a distance of 100 km, at a speed of 20 km/h. If it had gone two and a half times as fast, how much earlier would it have arrived at B?
11. Two men running towards each other at 4 m/s and 6 m/s respectively are one kilometre apart. How long will it take before they meet?
12. A car travelling at 90 km/h is 500 m behind another car travelling at 70 km/h in the same direction. How long will it take the first car to catch the second?
13. How long is a train which passes a signal in twenty seconds at a speed of 108 km/h?
14. A train of length 180 m approaches a tunnel of length 620 m. How long will it take the train to pass completely through the tunnel at a speed of 54 km/h?
15. An earthworm of length 15 cm is crawling along at 2 cm/s. An ant overtakes the worm in 5 seconds. How fast is the ant walking?
16. A train of length 100 m is moving at a speed of 50 km/h. A horse is running alongside the train at a speed of 56 km/h. How long will it take the horse to overtake the train?
17. A car completes a journey at an average speed of 40 km/h. At what speed must it travel on the return journey if the average speed for the complete journey (out and back) is 60 km/h?

Mixed problems

Exercise 26

1. Fill in the blank spaces in the table so that each row contains equivalent values.

fraction	decimal	percentage
	0.28	
		64%
$\frac{5}{8}$		



2. An engine pulls four identical carriages. The engine is $\frac{2}{3}$ the length of a carriage and the total length of the train is 86.8 m. Find the length of the engine.
3. A wedding cake is made from the ingredients listed below.
500 g flour, 450 g butter, 470 g sugar,
1.8 kg mixed fruit, 4 eggs (weighing 70 g each)
The cake loses 12% of its weight during cooking. What is its final weight?
4. Abdul left his home at 7.35 a.m. and drove at an average speed of 45 km/h arriving at the airport at 8.50 a.m. How far is his home from the airport?
5. Joe's parents have agreed to lend him 60% of the cost of buying a second-hand car. If Joe still has to find \$328 himself, how much does the car cost?
6. Which bag of potatoes is the better value:
Bag A, 6 kg for \$4.14 or
Bag B, 2.5 kg for \$1.80?
7. An aeroplane was due to take off from Madrid airport at 18:42 but it was 35 min late. During the flight, thanks to a tail wind, the plane made up the time and in fact landed 16 min before its scheduled arrival time of 00:05. (Assume that the plane did not cross any time zones on its journey.)
(a) What time did the aeroplane take off?
(b) What time did it land?
8. A 20 cent coin is 1.2 mm thick. What is the value of a pile of 20 cent coins which is 21.6 cm high?
9. Work out $\frac{3}{5} + 0.12 + 6\%$ of 10.

Exercise 27

1. Find the distance travelled by light in one hour, given that the speed of light is 300 000 kilometres per second.
Give the answer in kilometres in standard form.
2. When the lid is left off an ink bottle, the ink evaporates at a rate of $2.5 \times 10^{-6} \text{ cm}^3/\text{s}$. A full bottle contains 36 cm^3 of ink. How long, to the nearest day, will it take for all the ink to evaporate?
3. Convert 3.35 hours into hours and minutes.
4. When I think of a number, multiply it by 6 and subtract 120, my answer is -18 . What was my original number?

Remember
There are 60 minutes in 1 hour.

5. The cost of advertising in a local paper for one week is:

28 cents per word plus 75 cents

- (a) What is the cost of an advertisement of 15 words for one week?
 (b) What is the greatest number of words in an advertisement costing up to \$8 for one week?
 (c) If an advertisement is run for two weeks, the cost for the second week is reduced by 30%. Calculate the total cost for an advertisement of 22 words for two weeks.
6. Bronze is made up of zinc, tin and copper in the ratio 1 : 4 : 95.
 A bronze statue contains 120 g of tin. Find the quantities of the other two metals required and the total weight of the statue.

Exercise 28

1. In the diagram $\frac{5}{6}$ of the circle is shaded and $\frac{2}{3}$ of the triangle is shaded.
 What is the ratio of the area of the circle to the area of the triangle?

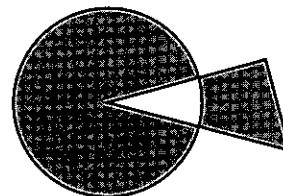

2. Find the exact answer to the following by first working out a rough answer and then using the information given.

Do *not* use a calculator.

- (a) If $142.3 \times 98.5 = 14\,016.55$ find $140.1655 \div 14.23$
 (b) If $76.2 \times 8.6 = 655.32$ find $6553.2 \div 86$
 (c) If $22.3512 \div 0.268 = 83.4$ find 8340×26.8
 (d) If $1.6781 \div 17.3 = 0.097$ find 9700×0.173
3. A sales manager reports an increase of 28% in sales this year compared to last year.
 The increase was \$70 560.
 What were the sales last year?

4. Small cubes of side 1 cm are stuck together to form a large cube of side 4 cm. Opposite faces of the large cube are painted the same colour, but adjacent faces are different colours. The three colours used are red, black and green.
- (a) How many small cubes have just one red and one green face?
 (b) How many small cubes are painted on one face only?
 (c) How many small cubes have one red, one green and one black face?
 (d) How many small cubes have no faces painted?

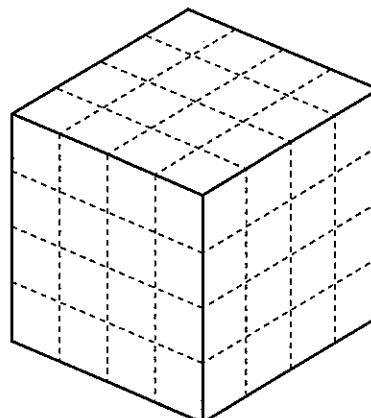



5. The bullet from a rifle travels at a speed of 3×10^4 cm/s. Work out the length of time in seconds taken for the bullet to hit a target 54 m away.
6. A sewing machine cost \$162.40 after a price increase of 16%. Find the price before the increase.
7. To get the next number in a sequence you double the previous number and subtract two.
The fifth number in the sequence is 50.
Find the first number.
8. A code uses 1 for A, 2 for B, 3 for C and so on up to 26 for Z. Coded words are written without spaces to confuse the enemy, so 18 could be AH or R. Decode the following message.
208919 919 1 2251825 199121225 31545
9. A coach can take 47 passengers. How many coaches are needed to transport 1330 passengers?

1.8 Calculator

In this book, the keys are described thus:

$\boxed{+}$ add	$\boxed{\sqrt{\quad}}$ square root
$\boxed{-}$ subtract	$\boxed{x^2}$ square
$\boxed{\times}$ multiply	$\boxed{1/x}$ reciprocal
$\boxed{\div}$ divide	$\boxed{y^x}$ raise number y to the power x
$\boxed{=}$ equals	

Using the $\boxed{\text{ANS}}$ button

The $\boxed{\text{ANS}}$ button can be used as a 'short term memory'. It holds the answer from the previous calculation.

Example

Evaluate the following to 4 significant figures:

(a) $\frac{5}{1.2 - 0.761}$ (b) $\left(\frac{1}{0.084}\right)^4$ (c) $\sqrt[3]{3.2 \times (1.7 - 1.64)}$

(a) Find the bottom line first.

$\boxed{1.2} \boxed{-} \boxed{0.761} \boxed{\text{EXE}} \boxed{5} \boxed{\div} \boxed{\text{ANS}} \boxed{\text{EXE}}$

The calculator reads 11.38952164

\therefore Answer = 11.39 (to four sig. fig.)

Note: The $\boxed{\text{EXE}}$ button works the same as the $\boxed{=}$ button.

(b) $\left(\frac{1}{0.084}\right)^4$

$$\boxed{0.084} \boxed{1/x} \boxed{y^x} \boxed{4} \boxed{=}$$

Answer 20 090 (to four sig. fig.)

(c) $\sqrt[3]{3.2(1.7 - 1.64)}$

$$\boxed{1.7} \boxed{-} \boxed{1.64} \boxed{=} \boxed{\times} \boxed{3.2} \boxed{=}$$

$$\boxed{y^x} \boxed{0.333333} \boxed{=}$$

Answer 0.5769 (to four sig. fig.)

Note: To find a cube root, raise to the power $\frac{1}{3}$, or as a decimal 0.333 ...**Exercise 29**

Use a calculator to evaluate the following, giving the answers to 4 significant figures:

- | | | | |
|---|---|--|---|
| 1. $\frac{7.351 \times 0.764}{1.847}$ | 2. $\frac{0.0741 \times 14\,700}{0.746}$ | 3. $\frac{0.0741 \times 9.61}{23.1}$ | 4. $\frac{417.8 \times 0.00841}{0.07324}$ |
| 5. $\frac{8.41}{7.601 \times 0.00847}$ | 6. $\frac{4.22}{1.701 \times 5.2}$ | 7. $\frac{9.61}{17.4 \times 1.51}$ | 8. $\frac{8.71 \times 3.62}{0.84}$ |
| 9. $\frac{0.76}{0.412 - 0.317}$ | 10. $\frac{81.4}{72.6 + 51.92}$ | 11. $\frac{111}{27.4 + 2960}$ | 12. $\frac{27.4 + 11.61}{5.9 - 4.763}$ |
| 13. $\frac{6.51 - 0.1114}{7.24 + 1.653}$ | 14. $\frac{5.71 + 6.093}{9.05 - 5.77}$ | 15. $\frac{0.943 - 0.788}{1.4 - 0.766}$ | 16. $\frac{2.6}{1.7} + \frac{1.9}{3.7}$ |
| 17. $\frac{8.06}{5.91} - \frac{1.594}{1.62}$ | 18. $\frac{4.7}{11.4 - 3.61} + \frac{1.6}{9.7}$ | 19. $\frac{3.74}{1.6 \times 2.89} - \frac{1}{0.741}$ | 20. $\frac{1}{7.2} - \frac{1}{14.6}$ |
| 21. $\frac{1}{0.961} \times \frac{1}{0.412}$ | 22. $\frac{1}{7} + \frac{1}{13} - \frac{1}{8}$ | 23. $4.2 \left(\frac{1}{5.5} - \frac{1}{7.6} \right)$ | 24. $\sqrt{9.61 + 0.1412}$ |
| 25. $\sqrt{\left(\frac{8.007}{1.61} \right)}$ | 26. $(1.74 + 9.611)^2$ | 27. $\left(\frac{1.63}{1.7 - 0.911} \right)^2$ | 28. $\left(\frac{9.6}{2.4} - \frac{1.5}{0.74} \right)^2$ |
| 29. $\sqrt{\left(\frac{4.2 \times 1.611}{9.83 \times 1.74} \right)}$ | 30. $(0.741)^3$ | 31. $(1.562)^5$ | 32. $(0.32)^3 + (0.511)^4$ |
| 33. $(1.71 - 0.863)^6$ | 34. $\left(\frac{1}{0.971} \right)^4$ | 35. $\sqrt[3]{(4.714)}$ | 36. $\sqrt[3]{(0.9316)}$ |
| 37. $\sqrt[3]{\left(\frac{4.114}{7.93} \right)}$ | 38. $\sqrt[3]{(0.8145 - 0.799)}$ | 39. $\sqrt[3]{(8.6 \times 9.71)}$ | 40. $\sqrt[3]{\left(\frac{1.91}{4.2 - 3.766} \right)}$ |
| 41. $\left(\frac{1}{7.6} - \frac{1}{18.5} \right)^3$ | 42. $\frac{\sqrt{(4.79)} + 1.6}{9.63}$ | 43. $\frac{(0.761)^2 - \sqrt{(4.22)}}{1.96}$ | 44. $\sqrt[3]{\left(\frac{1.74 \times 0.761}{0.0896} \right)}$ |
| 45. $\left(\frac{8.6 \times 1.71}{0.43} \right)^3$ | 46. $\frac{9.61 - \sqrt{(9.61)}}{9.61^2}$ | 47. $\frac{9.6 \times 10^4 \times 3.75 \times 10^7}{8.88 \times 10^6}$ | 48. $\frac{8.06 \times 10^{-4}}{1.71 \times 10^{-6}}$ |

49. $\frac{3.92 \times 10^{-7}}{1.884 \times 10^{-11}}$ 50. $\left(\frac{1.31 \times 2.71 \times 10^5}{1.91 \times 10^4}\right)^5$ 51. $\left(\frac{1}{9.6} - \frac{1}{9.99}\right)^{10}$ 52. $\frac{\sqrt[3]{(86.6)}}{\sqrt{(4.71)}}$
53. $\frac{23.7 \times 0.0042}{12.48 - 9.7}$ 54. $\frac{0.482 + 1.6}{0.024 \times 1.83}$ 55. $\frac{8.52 - 1.004}{0.004 - 0.0083}$ 56. $\frac{1.6 - 0.476}{2.398 \times 41.2}$
57. $\left(\frac{2.3}{0.791}\right)^7$ 58. $\left(\frac{8.4}{28.7 - 0.47}\right)^3$ 59. $\left(\frac{5.114}{7.332}\right)^5$ 60. $\left(\frac{4.2}{2.3} + \frac{8.2}{0.52}\right)^3$
61. $\frac{1}{8.2^2} - \frac{3}{19^2}$ 62. $\frac{100}{11^3} + \frac{100}{12^3}$ 63. $\frac{7.3 - 4.291}{2.6^2}$ 64. $\frac{9.001 - 8.97}{0.95^3}$
65. $\frac{10 \cdot 1^2 + 9 \cdot 4^2}{9.8}$ 66. $(3.6 \times 10^{-8})^2$ 67. $(8.24 \times 10^4)^3$
68. $(2.17 \times 10^{-3})^3$ 69. $(7.095 \times 10^{-6})^{\frac{1}{3}}$ 70. $\sqrt[3]{\left(\frac{4.7}{2.3^2}\right)}$

1.9 Using a spreadsheet on a computer

This section is written for use with Microsoft Excel. Other spreadsheet programs work in a similar way.

Select Microsoft Excel from the desk top.

A spreadsheet appears on your screen as a grid with rows numbered 1, 2, 3, 4, ... and the columns lettered A, B, C, D, ...

The result should be a window like the one below.

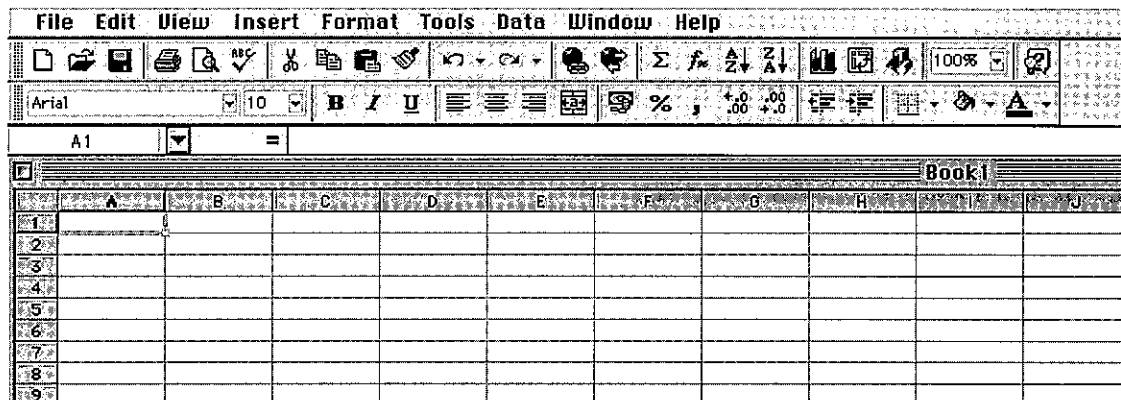

Cell The spaces on the spreadsheet are called cells. Individual cells are referred to as A1, B3, F9, like grid references. Cells may contain *labels*, *values* or *formulae*. The current cell has a black border.

Label Any words, headings or messages used to help the layout and organisation of the spreadsheet.

Value A number placed in a cell. It may be used as input to a calculation.

Tasks 1, 2 and 3 are written for you to become familiar with how the main functions of a spreadsheet program work. Afterwards there are sections on different topics where spreadsheets can be used.

- Task 1.** To generate the whole numbers from 1 to 10 in column A.
- In cell A1 type '1' and press *Return*. This will automatically take you to the cell below. [NOTE that you must use the *Return* button and not the arrow keys to move down the column.]
 - In cell A2 type the formula '= A1 + 1' and press *Return*. [NOTE that the = sign is needed before any formula.]
 - We now want to copy the formula in A2 down column A as far as A10. Click on A2 again and put the arrow in the bottom right corner of cell A2 (a + sign will appear) and drag down to A10.
- Task 2.** To generate the odd numbers in column B.
- In B1 type '1' (press *Return*).
 - In B2 type the formula '= B1 + 2' (press *Return*).
 - Click in B2 and copy the formula down column B as far as B10.
- Task 3.** To generate the first 15 square numbers.
- As before generate the numbers from 1 to 15 in cells A1 to A15.
 - In B1 put the formula '= A1 * A1' and press *Return*.
 - Click in B1 and copy the formula down as far as B15.

Pie charts and bar charts using a spreadsheet on a computer

Example

Display the data about the activities in one day.

Enter the headings: *Sleep* in A1, *School* in B1 etc. [Use the *tab* key to move across the page.]

Enter the data: 8 in A2, 7 in B2 etc.

	A	B	C	D	E	F	G	H
1	Sleep	School	TV	Eating	Homework	Other		
2	8	7	1.5	1	1.5	5		
3								
4								
5								
6								
7								

Now highlight all the cells from A1 to F2. [Click on A1 and drag across to F2.]

Click on the () Chart wizard on the toolbar.

Select 'pie' and then choose one of the examples displayed. Follow the on-screen prompts.

Alternatively, for a bar chart, select 'charts' after clicking on the chart wizard. Proceed as above.

You will be able to display your charts with various '3D' effects possibly in colour. This approach is recommended when you are presenting data that you have collected as part of an investigation.

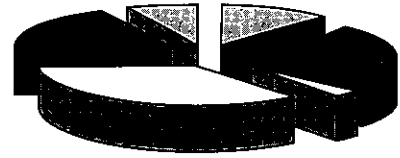

Scatter graphs on a computer

Example

Plot a scatter graph showing the marks of 10 students in Maths and Science.

Enter the headings: *Maths* in A1, *Science* in B1
Enter the data as shown.

Now highlight all the cells from A2 to B11.
[Click on A1 and drag across and down to B11.]

Click on the () Chart wizard on the toolbar.

Select XY (Scatter) and select the picture which looks like a scatter graph.

Follow the on-screen prompts.

On 'Titles' enter: Chart title: Maths/Science results
Value (X) axis: Maths
Value (Y) axis: Science

	A	B
1	Maths	Science
2	23	30
3	45	41
4	73	67
5	35	74
6	67	77
7	44	50
8	32	41
9	66	55
10	84	70
11	36	32

Experiment with 'Axes', 'Gridlines', 'Legend' and 'Data Labels'.

Task Enter the data on a spreadsheet and print a scatter graph.
What does each scatter graph show?

(a)	Height	Armspan	(b)	Temperature	Sales
	162	160		23	7
	155	151		18	14
	158	157		7	23
	142	144		20	9
	146	148		4	30
	165	163		12	19
	171	167		15	15
	148	150		18	15
	150	147		10	20

Revision exercise 1A

1. Evaluate, without a calculator:

(a) $148 \div 0.8$

(c) $(0.2)^2 \div (0.1)^3$

(e) $1\frac{3}{4} \times 1\frac{3}{5}$

(b) $0.024 \div 0.00016$

(d) $2 - \frac{1}{2} - \frac{1}{3} - \frac{1}{4}$

(f) $\frac{1\frac{1}{6}}{1\frac{2}{3} + 1\frac{1}{4}}$

2. On each bounce, a ball rises to $\frac{4}{5}$ of its previous height. To what height will it rise after the third bounce, if dropped from a height of 250 cm?3. A man spends $\frac{1}{3}$ of his salary on accommodation and $\frac{2}{5}$ of the remainder on food. What fraction is left for other purposes?4. $a = \frac{1}{2}$, $b = \frac{1}{4}$. Which one of the following has the greatest value?

(i) ab (ii) $a + b$ (iii) $\frac{a}{b}$ (iv) $\frac{b}{a}$ (v) $(ab)^2$

5. Express 0.05473:

(a) correct to three significant figures

(b) correct to three decimal places

(c) in standard form.

6. Evaluate $\frac{2}{3} + \frac{4}{7}$, correct to three decimal places.

7. Evaluate the following and give the answer in standard form:

(a) $3600 \div 0.00012$ (b) $\frac{3.33 \times 10^4}{9 \times 10^{-1}}$ (c) $(30\,000)^3$

8. (a) \$143 is divided in the ratio 2 : 3 : 6; calculate the smallest share.

(b) A prize is divided between three people X, Y and Z. If the ratio of X's share to Y's share is 3 : 1 and Y's share to Z's share is 2 : 5, calculate the ratio of X's share to Z's share.

(c) If $a : 3 = 12 : a$, calculate the positive value of a .

9. Labour costs, totalling \$47.25, account for 63% of a car repair bill. Calculate the total bill.

10. (a) Convert to percentages:

(i) 0.572 (ii) $\frac{7}{8}$

(b) Express 2.6 kg as a percentage of 6.5 kg.

(c) In selling a red herring for 92c, a fishmonger makes a profit of 15%. Find the cost price of the fish.

11. The length of a rectangle is decreased by 25% and the breadth is increased by 40%. Calculate the percentage change in the area of the rectangle.

12. (a) What sum of money, invested at 9% interest per year, is needed to provide an income of \$45 per year?

(b) A particle increases its speed from 8×10^5 m/s to 1.1×10^6 m/s. What is the percentage increase?



13. An English family on holiday in France exchanged £450 for euros when the exchange rate was 1.41 euros to the pound. They spent 500 euros and then changed the rest back into pounds, by which time the exchange rate had become 1.46 euros to the pound. How much did the holiday cost? (Answer in pounds.)
14. Given that
- $$t = 2\pi\sqrt{\left(\frac{l}{g}\right)},$$
- find the value of t , to three sig. fig., when $l = 2.31$ and $g = 9.81$
15. A map is drawn to a scale of 1 : 10 000. Find:
- the distance between two railway stations which appear on the map 24 cm apart.
 - the area, in square kilometres, of a lake which has an area of 100 cm^2 on the map.
16. A map is drawn to a scale of 1 : 2000. Find:
- the actual distance between two points, which appear 15 cm apart on the map.
 - the length on the map of a road, which is 1.2 km in length.
 - the area on the map of a field, with an actual area of $60\,000 \text{ m}^2$.
17. (a) On a map, the distance between two points is 16 cm. Calculate the scale of the map if the actual distance between the points is 8 km.
- (b) On another map, two points appear 1.5 cm apart and are in fact 60 km apart. Calculate the scale of the map.
18. (a) A house is bought for \$20 000 and sold for \$24 400. What is the percentage profit?
- (b) A piece of meat, initially weighing 2.4 kg, is cooked and subsequently weighs 1.9 kg. What is the percentage loss in weight?
- (c) An article is sold at a 6% loss for \$225.60. What was the cost price?
19. (a) Convert into metres per second:
- 700 cm/s
 - 720 km/h
 - 18 km/h
- (b) Convert into kilometres per hour:
- 40 m/s
 - 0.6 m/s
20. (a) Calculate the speed (in metres per second) of a slug which moves a distance of 30 cm in 1 minute.
- (b) Calculate the time taken for a bullet to travel 8 km at a speed of 5000 m/s.
- (c) Calculate the distance flown, in a time of four hours, by a pigeon which flies at a speed of 12 m/s.
21. A motorist travelled 200 km in five hours. Her average speed for the first 100 km was 50 km/h. What was her average speed for the second 100 kilometres?

22. 1 3 8 9 10

From these numbers, write down:

- (a) the prime number, (Note: 1 is NOT a prime number)
 (b) a multiple of 5,
 (c) two square numbers,
 (d) two factors of 32.
 (e) Find two numbers m and n from the list such that $m = \sqrt{n}$ and $n = \sqrt{81}$.
 (f) If each of the numbers in the list can be used once, find p, q, r, s, t such that $(p + q)r = 2(s + t) = 36$.

23. The value of t is given by

$$t = 2\pi \sqrt{\left(\frac{2 \cdot 31^2 + 0.9^2}{2 \cdot 31 \times 9.81}\right)}.$$

Without using a calculator, and using suitable approximate values for the numbers in the formula, find an estimate for the value of t . (To earn the marks in this question you must show the various stages of your working.)

24. Throughout his life Mr Cram's heart has beat at an average rate of 72 beats per minute. Mr Cram is sixty years old. How many times has his heart beat during his life? Give the answer in standard form correct to two significant figures.

25. Estimate the answer correct to one significant figure. Do not use a calculator.

- (a) $(612 \times 52) \div 49.2$ (b) $(11.7 + 997.1) \times 9.2$
 (c) $\sqrt{\left(\frac{91.3}{10.1}\right)}$ (d) $\pi\sqrt{(5.2^2 + 18.2)}$

26. Evaluate the following using a calculator: (answers to four sig. fig.)

- (a) $\frac{0.74}{0.81 \times 1.631}$ (b) $\sqrt{\left(\frac{9.61}{8.34 - 7.41}\right)}$
 (c) $\left(\frac{0.741}{0.8364}\right)^4$ (d) $\frac{8.4 - 7.642}{3.333 - 1.735}$

27. Evaluate the following and give the answers to three significant figures:

- (a) $\sqrt[3]{(9.61 \times 0.0041)}$ (b) $\left(\frac{1}{9.5} - \frac{1}{11.2}\right)^3$
 (c) $\frac{15.6 \times 0.714}{0.0143 \times 12}$ (d) $\sqrt[4]{\left(\frac{1}{5 \times 10^3}\right)}$

28. The edges of a cube are all increased by 10%. What is the percentage increase in the volume?

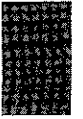

Examination exercise 1B

- A family arrives home at 01:10 after a journey that took $7\frac{1}{2}$ hours.
At what time on the previous day did their journey start?

N 95 2
- After adding a profit of 20%, the selling price of a television is \$684. Calculate the cost price.

N 95 2
- Insert one of the symbols $>$, $=$, $<$ to make each of the statements correct.

(a) $(0.2)^2$ 4×10^{-2} (b) $\frac{37}{73}$ 0.507 N 95 2
- A map has a scale of 1 : 50 000.

(a) A road on the map is 10 cm long. What is the real length of the road in kilometres?

(b) The area of a farm on the map is 6 cm^2 . What is the real area of the farm in hectares?
[1 hectare = $10\,000 \text{ m}^2 = 0.01 \text{ km}^2$]

J 96 2
- $\frac{82}{99}$, 82%, $\sqrt{0.674}$

(a) Write these in order of size, starting with the smallest.

(b) Find the difference between the largest and the smallest, giving your answer correct to two significant figures.

J 97 2
- The ratio of men : women : children living in Newtown is 6 : 7 : 3.
There are 42 000 women.

(a) (i) How many children live in Newtown?
(ii) How many people altogether live in Newtown?

(b) The 42 000 women is an increase of 20% on the number of women ten years ago.
Calculate how many women lived in Newtown ten years ago.

(c) Twelve thousand of the children attend school and 48% of them are boys.

(i) Calculate the number of boys and the number of girls at school.

(ii) The average age of the 12 000 children is exactly 10.54 years.
The average age of the boys is exactly 10.35 years.
Calculate the average age of the girls, correct to two decimal places.

J 98 4

7. A cinema has 200 seats. Ticket prices are \$5 for an adult and \$2.50 for a child.
- (a) One evening, 80% of the seats in the cinema are occupied. Twenty of the people present are children. Calculate the total money taken from the sale of tickets.
- (b) Another evening, x children are present and **all** the seats are occupied. The money taken for tickets is \$905.
- (i) Write down an equation in x .
- (ii) Calculate the value of x .
- (c) The money taken for tickets for a week is \$10 800. This sum is divided between costs, wages and profit in the ratio 2 : 3 : 7. Calculate:
- (i) the profit for the week,
- (ii) the simple interest earned if this profit is invested at a rate of 5% per annum for 4 months. J 97 4

You can find out about equations on page 52.

8. Ahmed earns \$20 000 each year.
- (a) In 1991, he paid no tax on the first \$3000 of his earnings. He paid 25% of the rest as tax. Show that he paid \$4250 as tax.
- (b) In 1992, he paid no tax on the first \$4000 of his earnings. He paid 30% of the rest as tax. Calculate how much he paid as tax.
- (c) In 1993, he paid no tax on the first \$ x of his earnings. He paid 30% of the rest as tax.
- (i) Find an expression in terms of x for the amount of tax he paid.
- (ii) Calculate the value of x if he paid \$4950 as tax. J 95 4

9. (a) As the product of its prime factors,
 $1080 = 2 \times 2 \times 2 \times 3 \times 3 \times 3 \times 5$.
 Write 135, 210 and 1120 as the product of their prime factors.
- (b) Copy this grid.

$a = 1$	$b =$	$c =$
$d =$	$e =$	$f =$
$g =$	$h =$	$i = 8$

The nine digits 1, 2, 3, 4, 5, 6, 7, 8, 9 are to be placed in your grid in such a way that the following four statements are *all* true.

$$\begin{aligned} a \times b \times d \times e &= 135 \\ b \times c \times e \times f &= 1080 \\ d \times e \times g \times h &= 210 \\ e \times f \times h \times i &= 1120 \end{aligned}$$

The digits 1 and 8 have already been placed for you.



Use your answers to part (a) to answer the following questions.

- (i) Which is the only digit, other than 1, that is a factor of 135, 1080, 210 and 1120?
- (ii) Which is the only letter to appear in all four statements above?
- (iii) 7 is a factor of only two of the numbers 135, 1080, 210 and 1120. Which two?
- (c) Now complete the grid. N 96 4
10. The first five terms of a sequence are 4, 9, 16, 25, 36, ...
Find:
(a) the 10th term,
(b) the n th term. N 03 2
11. $\mathcal{E} = \{-2\frac{1}{2}, -1, \sqrt{2}, 3.5, \sqrt{30}, \sqrt{36}\}$
 $X = \{\text{integers}\}$
 $Y = \{\text{irrational numbers}\}$
List the members of:
(a) X ,
(b) Y . N 03 2
12. Abdul invested \$240 when the rate of simple interest was $r\%$ per year.
After m months the interest was \$ I .
Write down and simplify an expression for I , in terms of m and r .
N 03 2
13. A baby was born with a mass of 3.6 kg.
After three months this mass had increased to 6 kg.
Calculate the percentage increase in the mass of the baby. N 03 2
14. In 1950, the population of Switzerland was 4 714 900
In 2000, the population was 7 087 000.
(a) Work out the percentage increase in the population from 1950 to 2000.
(b) (i) Write the 1950 population correct to 3 significant figures.
(ii) Write the 2000 population in standard form. J 03 2

2 ALGEBRA 1



Isaac Newton (1642–1727) is thought by many to have been one of the greatest intellects of all time. He went to Trinity College Cambridge in 1661 and by the age of 23 he had made three major discoveries: the nature of colours, the calculus and the law of gravitation. He used his version of the calculus to give the first satisfactory explanation of the motion of the Sun, the Moon and the stars. Because he was extremely sensitive to criticism, Newton was always very secretive, but he was eventually persuaded to publish his discoveries in 1687.

- 3** Use directed numbers in practical situations
- 20** Substitute numbers in formulae; construct and transform more complicated formulae and equations
- 21** Manipulate directed numbers; expand products of algebraic expressions; factorise expressions
- 24** Solve simple linear equations in one unknown; solve simultaneous linear equations in two unknowns; solve quadratic equations by factorisation and use of the formula

2.1 Directed numbers

To add two directed numbers with the same sign, find the sum of the numbers and give the answer the same sign.

Example 1

$$\begin{aligned}
 +3 + (+5) &= +3 + 5 = +8 \\
 -7 + (-3) &= -7 - 3 = -10 \\
 -9 \cdot 1 + (-3 \cdot 1) &= 9 \cdot 1 - 3 \cdot 1 = -12 \cdot 2 \\
 -2 + (-1) + (-5) &= (-2 - 1) - 5 \\
 &= -3 - 5 \\
 &= -8
 \end{aligned}$$

To add two directed numbers with different signs, find the difference between the numbers and give the answer the sign of the larger number.

Example 2

$$+7 + (-3) = +7 - 3 = +4$$

$$+9 + (-12) = +9 - 12 = 3$$

$$-8 + (+4) = -8 + 4 = -4$$

To subtract a directed number, change its sign and add.

Example 3

$$+7 - (+5) = +7 - 5 = +2$$

$$+7 - (-5) = +7 + 5 = +12$$

$$-8 - (+4) = -8 - 4 = -12$$

$$-9 - (-11) = -9 + 11 = +2$$

Exercise 1

- | | | |
|-------------------------|--------------------------|--------------------------|
| 1. $+7 + (+6)$ | 2. $+11 + (+200)$ | 3. $-3 + (-9)$ |
| 4. $-7 + (-24)$ | 5. $-5 + (-61)$ | 6. $+0.2 + (+5.9)$ |
| 7. $+5 + (+4.1)$ | 8. $-8 + (-27)$ | 9. $+17 + (+1.7)$ |
| 10. $-2 + (-3) + (-4)$ | 11. $-7 + (+4)$ | 12. $+7 + (-4)$ |
| 13. $-9 + (+7)$ | 14. $+16 + (-30)$ | 15. $+14 + (-21)$ |
| 16. $-7 + (+10)$ | 17. $-19 + (+200)$ | 18. $+7.6 + (-9.8)$ |
| 19. $-1.8 + (+10)$ | 20. $-7 + (+24)$ | 21. $+7 - (+5)$ |
| 22. $+9 - (+15)$ | 23. $-6 - (+9)$ | 24. $-9 - (+5)$ |
| 25. $+8 - (+10)$ | 26. $-19 - (-7)$ | 27. $-10 - (+70)$ |
| 28. $-5.1 - (+8)$ | 29. $-0.2 - (+4)$ | 30. $+5.2 - (-7.2)$ |
| 31. $-4 + (-3)$ | 32. $+6 - (-2)$ | 33. $+8 + (-4)$ |
| 34. $-4 - (+6)$ | 35. $+7 - (-4)$ | 36. $+6 + (-2)$ |
| 37. $+10 - (+30)$ | 38. $+19 - (+11)$ | 39. $+4 + (-7) + (-2)$ |
| 40. $-3 - (+2) + (-5)$ | 41. $-17 - (-1) + (-10)$ | 42. $-5 + (-7) - (+9)$ |
| 43. $+9 + (-7) - (-6)$ | 44. $-7 - (-8)$ | 45. $-10.1 + (-10.1)$ |
| 46. $-75 - (-25)$ | 47. $-204 - (+304)$ | 48. $-7 + (-11) - (+11)$ |
| 49. $+17 - (+17)$ | 50. $-6 + (-7) - (+8)$ | 51. $+7 + (-7.1)$ |
| 52. $-11 - (-4) + (+3)$ | 53. $-2 - (-8.7)$ | 54. $+7 + (-11) + (+5)$ |
| 55. $-610 + (-240)$ | 56. $-7 - (-3) - (-8)$ | 57. $+9 - (-6) + (-9)$ |
| 58. $-1 - (-5) + (-8)$ | 59. $-2.1 + (-9.9)$ | 60. $-47 - (-16)$ |

When two directed numbers with the same sign are multiplied together, the answer is positive.

- $+7 \times (+3) = +21$
- $-6 \times (-4) = +24$

When two directed numbers with different signs are multiplied together, the answer is negative.

- $-8 \times (+4) = -32$
- $+7 \times (-5) = -35$
- $-3 \times (+2) \times (+5) = -6 \times (+5) = -30$

When dividing directed numbers, the rules are the same as in multiplication.

- $-70 \div (-2) = +35$
- $+12 \div (-3) = -4$
- $-20 \div (+4) = -5$

Exercise 2

- | | | | |
|------------------------------|---------------------------------|----------------------------------|---|
| 1. $+2 \times (-4)$ | 2. $+7 \times (+4)$ | 3. $-4 \times (-3)$ | 4. $-6 \times (-4)$ |
| 5. $-6 \times (-3)$ | 6. $+5 \times (-7)$ | 7. $-7 \times (-7)$ | 8. $-4 \times (+3)$ |
| 9. $+0.5 \times (-4)$ | 10. $-1\frac{1}{2} \times (-6)$ | 11. $-8 \div (+2)$ | 12. $+12 \div (+3)$ |
| 13. $+36 \div (-9)$ | 14. $-40 \div (-5)$ | 15. $-70 \div (-1)$ | 16. $-56 \div (+8)$ |
| 17. $-\frac{1}{2} \div (-2)$ | 18. $-3 \div (+5)$ | 19. $+0.1 \div (-10)$ | 20. $-0.02 \div (-100)$ |
| 21. $-11 \times (-11)$ | 22. $-6 \times (-1)$ | 23. $+12 \times (-50)$ | 24. $-\frac{1}{2} \div (+\frac{1}{2})$ |
| 25. $-600 \div (+30)$ | 26. $-5.2 \div (+2)$ | 27. $+7 \times (-100)$ | 28. $-6 \div (-\frac{1}{3})$ |
| 29. $100 \div (-0.1)$ | 30. -8×-80 | 31. $-3 \times (-2) \times (-1)$ | 32. $+3 \times (-7) \times (+2)$ |
| 33. $+0.4 \div (-1)$ | 34. $-16 \div (+40)$ | 35. $+0.2 \times (-1000)$ | 36. $-7 \times (-5) \times (-1)$ |
| 37. $-14 \div (+7)$ | 38. $-7 \div (-14)$ | 39. $+1\frac{1}{4} \div (-5)$ | 40. $-6 \times (-\frac{1}{2}) \times (-30)$ |

Exercise 3

- | | | | |
|------------------------|-----------------------------------|-----------------------------|-------------------------|
| 1. $-7 + (-3)$ | 2. $-6 - (-7)$ | 3. $-4 \times (-3)$ | 4. $-4 \times (+7)$ |
| 5. $4 - (+6)$ | 6. $-4 \times (-4)$ | 7. $+6 \div (-2)$ | 8. $+8 - (-6)$ |
| 9. $-7 \times (+4)$ | 10. $-8 \div (-2)$ | 11. $+10 \div (-60)$ | 12. (-3^2) |
| 13. $40 - (+70)$ | 14. $-6 \times (-4)$ | 15. $(-1)^5$ | 16. $-8 \div (+4)$ |
| 17. $+10 \times (-3)$ | 18. $-7 \times (-1)$ | 19. $+10 + (-7)$ | 20. $+12 - (-4)$ |
| 21. $+100 + (-7)$ | 22. $-60 \times (-40)$ | 23. $-20 \div (-2)$ | 24. $(-1)^{20}$ |
| 25. $6 - (+10)$ | 26. $-6 \times (+4) \times (-2)$ | 27. $+8 \div (-8)$ | 28. $0 \times (-6)$ |
| 29. $(-2)^3$ | 30. $+100 - (-70)$ | 31. $+18 \div (-6)$ | 32. $(-1)^{12}$ |
| 33. $-6 - (-7)$ | 34. $(-2)^2 + (-4)$ | 35. $+8 - (-7)$ | 36. $+7 + (-2)$ |
| 37. $-6 \times (+0.4)$ | 38. $-3 \times (-6) \times (-10)$ | 39. $(-2)^2 + (+1)$ | 40. $+6 - (+1000)$ |
| 41. $(-3)^2 - 7$ | 42. $-12 \div \frac{1}{4}$ | 43. $-30 \div -\frac{1}{2}$ | 44. $5 - (+7) + (-0.5)$ |
| 45. $(-2)^5$ | 46. $0 \div (-\frac{1}{3})$ | 47. $(-0.1)^2 \times (-10)$ | 48. $3 - (+19)$ |
| 49. $2.1 + (-6.4)$ | 50. $(-\frac{1}{2})^2 \div (-4)$ | | |

2.2 Formulae

When a calculation is repeated many times it is often helpful to use a formula. Publishers use a formula to work out the selling price of a book based on the production costs and the expected sales of the book.

Exercise 4

1. The final speed v of a car is given by the formula $v = u + at$.

[u = initial speed, a = acceleration, t = time taken]

Find v when $u = 15$ m/s, $a = 0.2$ m/s², $t = 30$ s.

2. The time period T of a simple pendulum is given by the formula

$$T = 2\pi\sqrt{\left(\frac{l}{g}\right)}, \text{ where } l \text{ is the length of the pendulum and } g \text{ is the}$$

gravitational acceleration. Find T when $l = 0.65$ m, $g = 9.81$ m/s² and $\pi = 3.142$.

3. The total surface area A of a cone is related to the radius r and the slant height l by the formula $A = \pi r(r + l)$. Find A when $r = 7$ cm and $l = 11$ cm.

4. The sum S of the squares of the integers from 1 to n is given by $S = \frac{1}{6}n(n + 1)(2n + 1)$. Find S when $n = 12$.

5. The acceleration a of a train is found using the formula $a = \frac{v^2 - u^2}{2s}$. Find a when $v = 20$ m/s, $u = 9$ m/s and $s = 2.5$ m.

6. Einstein's famous equation relating energy, mass and the speed of light is $E = mc^2$. Find E when $m = 0.0001$ and $c = 3 \times 10^8$.

7. The distance s travelled by an accelerating rocket is given by $s = ut + \frac{1}{2}at^2$. Find s when $u = 3$ m/s, $t = 100$ s and $a = 0.1$ m/s².

8. Find a formula for the area of the shape opposite, in terms of a , b and c .

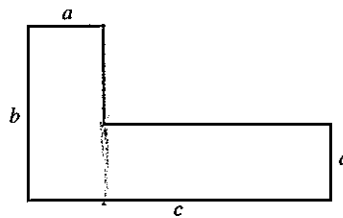

You can find out more about area in Unit 3 on page 82.

9. Find a formula for the length of the shaded part below, in terms of p , q and r .

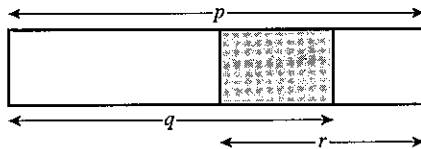

10. An intelligent fish lays brown eggs or white eggs and it likes to lay them in a certain pattern. Each brown egg is surrounded by six white eggs.

Here there are 3 brown eggs and 14 white eggs.

- (a) How many eggs does it lay altogether if it lays 200 brown eggs?
- (b) How many eggs does it lay altogether if it lays n brown eggs?

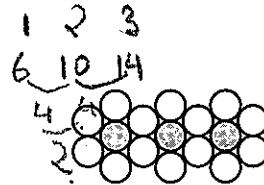

11. In the diagrams below the rows of black tiles are surrounded by white tiles.

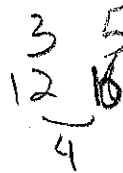

Find a formula for the number of white tiles which would be needed to surround a row of n black tiles.

ExampleWhen $a = 3$, $b = -2$, $c = 5$, find the value of:

(a) $3a + b$	(b) $ac + b^2$	(c) $\frac{a+c}{b}$	(d) $a(c-b)$
(a) $3a + b$ $= (3 \times 3) + (-2)$ $= 9 - 2$ $= 7$	(b) $ac + b^2$ $= (3 \times 5) + (-2)^2$ $= 15 + 4$ $= 19$	(c) $\frac{a+c}{b}$ $= \frac{3+5}{-2}$ $= \frac{8}{-2}$ $= -4$	(d) $a(c-b)$ $= 3[5 - (-2)]$ $= 3[7]$ $= 21$

Notice that working *down* the page is often easier to follow.**Exercise 5**

Evaluate the following:

For questions 1 to 12, $a = 3$, $c = 2$, $e = 5$.

1. $3a - 2$	2. $4c + e$	3. $2c + 3a$	4. $5e - a$
5. $e - 2c$	6. $e - 2a$	7. $4c + 2e$	8. $7a - 5e$
9. $c - e$	10. $10a + c + e$	11. $a + c - e$	12. $a - c - e$

For questions 13 to 24, $h = 3$, $m = -2$, $t = -3$.

13. $2m - 3$	14. $4t + 10$	15. $3h - 12$	16. $6m + 4$
17. $9t - 3$	18. $4h + 4$	19. $2m - 6$	20. $m + 2$
21. $3h + m$	22. $t - h$	23. $4m + 2h$	24. $3t - m$

For questions 25 to 36, $x = -2$, $y = -1$, $k = 0$.

25. $3x + 1$	26. $2y + 5$	27. $6k + 4$	28. $3x + 2y$
29. $2k + x$	30. xy	31. xk	32. $2xy$
33. $2(x + k)$	34. $3(k + y)$	35. $5x - y$	36. $3k - 2x$

 $2x^2$ means $2(x^2)$. $(2x^2)$ means 'work out $2x$ and then square it'. $-7x$ means $-7(x)$. $-x^2$ means $-1(x^2)$.**Example**When $x = -2$, find the value of:

(a) $2x^2 - 5x$	(b) $(3x)^2 - x^2$
(a) $2x^2 - 5x = 2(-2)^2 - 5(-2)$ $= 2(4) + 10$ $= 18$	(b) $(3x)^2 - x^2 = (3 \times -2)^2 - 1(-2)^2$ $= (-6)^2 - 1(4)$ $= 36 - 4$ $= 32$

Exercise 6If $x = -3$ and $y = 2$, evaluate the following:

- | | | | | |
|-----------------------|-------------------|--------------------|---------------------|---------------------|
| 1. x^2 | 2. $3x^2$ | 3. y^2 | 4. $4y^2$ | 5. $(2x)^2$ |
| 6. $2x^2$ | 7. $10 - x^2$ | 8. $10 - y^2$ | 9. $20 - 2x^2$ | 10. $20 - 3y^2$ |
| 11. $5 + 4x$ | 12. $x^2 - 2x$ | 13. $y^2 - 3x^2$ | 14. $x^2 - 3y$ | 15. $(2x)^2 - y^2$ |
| 16. $4x^2$ | 17. $(4x)^2$ | 18. $1 - x^2$ | 19. $y - x^2$ | 20. $x^2 + y^2$ |
| 21. $x^2 - y^2$ | 22. $2 - 2x^2$ | 23. $(3x)^2 + 3$ | 24. $11 - xy$ | 25. $12 + xy$ |
| 26. $(2x)^2 - (3y)^2$ | 27. $2 - 3x^2$ | 28. $y^2 - x^2$ | 29. $x^2 + y^3$ | 30. $\frac{x}{y}$ |
| 31. $10 - 3x$ | 32. $2y^2$ | 33. $25 - 3y$ | 34. $(2y)^2$ | 35. $-7 + 3x$ |
| 36. $-8 + 10y$ | 37. $(xy)^2$ | 38. xy^2 | 39. $-7 + x^2$ | 40. $17 + xy$ |
| 41. $-5 - 2x^2$ | 42. $10 - (2x)^2$ | 43. $x^2 + 3x + 5$ | 44. $2x^2 - 4x + 1$ | 45. $\frac{x^2}{y}$ |

ExampleWhen $a = -2$, $b = 3$, $c = -3$, evaluate:

(a) $\frac{2a(b^2 - a)}{c}$ (b) $\sqrt{a^2 + b^2}$

(a) $(b^2 - a) = 9 - (-2)$
 $= 11$

$$\therefore \frac{2a(b^2 - a)}{c} = \frac{2 \times (-2) \times (11)}{-3}$$
$$= 14\frac{2}{3}$$

(b) $a^2 + b^2 = (-2)^2 + (3)^2$
 $= 4 + 9$
 $= 13$

$$\sqrt{a^2 + b^2} = \sqrt{13}$$

Exercise 7

Evaluate the following:

In questions 1 to 16, $a = 4$, $b = -2$, $c = -3$.

- | | | | |
|-----------------------|------------------------|------------------------------------|------------------------------------|
| 1. $a(b + c)$ | 2. $a^2(b - c)$ | 3. $2c(a - c)$ | 4. $b^2(2a + 3c)$ |
| 5. $c^2(b - 2a)$ | 6. $2a^2(b + c)$ | 7. $2(a + b + c)$ | 8. $3c(a - b - c)$ |
| 9. $b^2 + 2b + a$ | 10. $c^2 - 3c + a$ | 11. $2b^2 - 3b$ | 12. $\sqrt{a^2 + c^2}$ |
| 13. $\sqrt{ab + c^2}$ | 14. $\sqrt{c^2 - b^2}$ | 15. $\frac{b^2}{a} + \frac{2c}{b}$ | 16. $\frac{c^2}{b} + \frac{4b}{a}$ |

In questions 17 to 32, $k = -3$, $m = 1$, $n = -4$.

- | | | | |
|----------------------------|--------------------------|-------------------------------|---|
| 17. $k^2(2m - n)$ | 18. $5m\sqrt{k^2 + n^2}$ | 19. $\sqrt{(kn + 4m)}$ | 20. $kmn(k^2 + m^2 + n^2)$ |
| 21. $k^2m^2(m - n)$ | 22. $k^2 - 3k + 4$ | 23. $m^3 + m^2 + n^2 + n$ | 24. $k^3 + 3k$ |
| 25. $m(k^2 - n^2)$ | 26. $m\sqrt{k - n}$ | 27. $100k^2 + m$ | 28. $m^2(2k^2 - 3n^2)$ |
| 29. $\frac{2k + m}{k - n}$ | 30. $\frac{kn - k}{2m}$ | 31. $\frac{3k + 2m}{2n - 3k}$ | 32. $\frac{k + m + n}{k^2 + m^2 + n^2}$ |

In questions 33 to 48, $w = -2$, $x = 3$, $y = 0$, $z = -\frac{1}{2}$.

33. $\frac{w}{z} + x$

34. $\frac{w+x}{z}$

35. $y\left(\frac{x+z}{w}\right)$

36. $x^2(z + wy)$

37. $x\sqrt{(x + wz)}$

38. $w^2\sqrt{(z^2 + y^2)}$

39. $2(w^2 + x^2 + y^2)$

40. $2x(w - z)$

41. $\frac{z}{w} + x$

42. $\frac{z+w}{x}$

43. $\frac{x+w}{z^2}$

44. $\frac{y^2 - w^2}{xz}$

45. $z^2 + 4z + 5$

46. $\frac{1}{w} + \frac{1}{z} + \frac{1}{x}$

47. $\frac{4}{z} + \frac{10}{w}$

48. $\frac{yz - xw}{xz - w}$

49. Find $K = \sqrt{\left(\frac{a^2 + b^2 + c^2 - 2c}{a^2 + b^2 + 4c}\right)}$ if $a = 3$, $b = -2$, $c = -1$.

50. Find $W = \frac{kmn(k + m + n)}{(k + m)(k + n)}$ if $k = \frac{1}{2}$, $m = -\frac{1}{3}$, $n = \frac{1}{4}$.

2.3 Brackets and simplifying

A term outside a bracket multiplies each of the terms inside the bracket.
This is the *distributive law*.

Example 1

$$3(x - 2y) = 3x - 6y$$

Example 2

$$2x(x - 2y + z) = 2x^2 - 4xy + 2xz$$

Example 3

$$7y - 4(2x - 3) = 7y - 8x + 12$$

In general,

numbers can be added to numbers

x 's can be added to x 's

y 's can be added to y 's

x^2 's can be added to x^2 's

But they must not be mixed.

Example 4

$$2x + 3y + 3x^2 + 2y - x = x + 5y + 3x^2$$

Example 5

$$\begin{aligned} 7x + 3x(2x - 3) &= 7x + 6x^2 - 9x \\ &= 6x^2 - 2x \end{aligned}$$

Exercise 8

Simplify as far as possible:

- | | | |
|---|---|---|
| 1. $3x + 4y + 7y$ | 2. $4a + 7b - 2a + b$ | 3. $3x - 2y + 4y$ |
| 4. $2x + 3x + 5$ | 5. $7 - 3x + 2 + 4x$ | 6. $5 - 3y - 6y - 2$ |
| 7. $5x + 2y - 4y - x^2$ | 8. $2x^2 + 3x + 5$ | 9. $2x - 7y - 2x - 3y$ |
| 10. $4a + 3a^2 - 2a$ | 11. $7a - 7a^2 + 7$ | 12. $x^2 + 3x^2 - 4x^2 + 5x$ |
| 13. $\frac{3}{a} + b + \frac{7}{a} - 2b$ | 14. $\frac{4}{x} - \frac{7}{y} + \frac{1}{x} + \frac{2}{y}$ | 15. $\frac{m}{x} + \frac{2m}{x}$ |
| 16. $\frac{5}{x} - \frac{7}{x} + \frac{1}{2}$ | 17. $\frac{3}{a} + b + \frac{2}{a} + 2b$ | 18. $\frac{n}{4} - \frac{m}{3} - \frac{n}{2} + \frac{m}{3}$ |
| 19. $x^3 + 7x^2 - 2x^3$ | 20. $(2x)^2 - 2x^2$ | 21. $(3y)^2 + x^2 - (2y)^2$ |
| 22. $(2x)^2 - (2y)^2 - (4x)^2$ | 23. $5x - 7x^2 - (2x)^2$ | 24. $\frac{3}{x^2} + \frac{5}{x^2}$ |

Remove the brackets and collect like terms:

- | | | |
|----------------------------|-----------------------------|----------------------------|
| 25. $3x + 2(x + 1)$ | 26. $5x + 7(x - 1)$ | 27. $7 + 3(x - 1)$ |
| 28. $9 - 2(3x - 1)$ | 29. $3x - 4(2x + 5)$ | 30. $5x - 2x(x - 1)$ |
| 31. $7x + 3x(x - 4)$ | 32. $4(x - 1) - 3x$ | 33. $5x(x + 2) + 4x$ |
| 34. $3x(x - 1) - 7x^2$ | 35. $3a + 2(a + 4)$ | 36. $4a - 3(a - 3)$ |
| 37. $3ab - 2a(b - 2)$ | 38. $3y - y(2 - y)$ | 39. $3x - (x + 2)$ |
| 40. $7x - (x - 3)$ | 41. $5x - 2(2x + 2)$ | 42. $3(x - y) + 4(x + 2y)$ |
| 43. $x(x - 2) + 3x(x - 3)$ | 44. $3x(x + 4) - x(x - 2)$ | 45. $y(3y - 1) - (3y - 1)$ |
| 46. $7(2x + 2) - (2x + 2)$ | 47. $7b(a + 2) - a(3b + 3)$ | 48. $3(x - 2) - (x - 2)$ |

Two brackets**Example 1**

$$\begin{aligned}(x + 5)(x + 3) &= x(x + 3) + 5(x + 3) \\ &= x^2 + 3x + 5x + 15 \\ &= x^2 + 8x + 15\end{aligned}$$

Example 2

$$\begin{aligned}(2x - 3)(4y + 3) &= 2x(4y + 3) - 3(4y + 3) \\ &= 8xy + 6x - 12y - 9\end{aligned}$$

Example 3

$$\begin{aligned}3(x + 1)(x - 2) &= 3[x(x - 2) + 1(x - 2)] \\ &= 3[x^2 - 2x + x - 2] \\ &= 3x^2 - 3x - 6\end{aligned}$$

Exercise 9

Remove the brackets and simplify:

- | | | | | |
|---------------------|---------------------|---------------------|---------------------|------------------------|
| 1. $(x + 1)(x + 3)$ | 2. $(x + 3)(x + 2)$ | 3. $(y + 4)(y + 5)$ | 4. $(x - 3)(x + 4)$ | 5. $(x + 5)(x - 2)$ |
| 6. $(x - 3)(x - 2)$ | 7. $(a - 7)(a + 5)$ | 8. $(z + 9)(z - 2)$ | 9. $(x - 3)(x + 3)$ | 10. $(k - 11)(k + 11)$ |

- ✓ 11. $(2x + 1)(x - 3)$ 12. $(3x + 4)(x - 2)$ 13. $(2y - 3)(y + 1)$ 14. $(7y - 1)(7y + 1)$
 15. $(3x - 2)(3x + 2)$ 16. $(3a + b)(2a + b)$ 17. $(3x + y)(x + 2y)$ 18. $(2b + c)(3b - c)$
 19. $(5x - y)(3y - x)$ 20. $(3b - a)(2a + 5b)$ 21. $2(x - 1)(x + 2)$ 22. $3(x - 1)(2x + 3)$
 23. $4(2y - 1)(3y + 2)$ 24. $2(3x + 1)(x - 2)$ 25. $4(a + 2b)(a - 2b)$ 26. $x(x - 1)(x - 2)$
 27. $2x(2x - 1)(2x + 1)$ 28. $3y(y - 2)(y + 3)$ 29. $x(x + y)(x + z)$ ✓ 30. $3z(a + 2m)(a - m)$

Be careful with an expression like $(x - 3)^2$. It is not $x^2 - 9$ or even $x^2 + 9$.

$$\begin{aligned}
 (x - 3)^2 &= (x - 3)(x - 3) \\
 &= x(x - 3) - 3(x - 3) \\
 &= x^2 - 6x + 9
 \end{aligned}$$

Another common mistake occurs with an expression like $4 - (x - 1)^2$.

$$\begin{aligned}
 4 - (x - 1)^2 &= 4 - 1(x - 1)(x - 1) \\
 &= 4 - 1(x^2 - 2x + 1) \\
 &= 4 - x^2 + 2x - 1 \\
 &= 3 + 2x - x^2
 \end{aligned}$$

Exercise 10

Remove the brackets and simplify:

1. $(x + 4)^2$ 2. $(x + 2)^2$ 3. $(x - 2)^2$ 4. $(2x + 1)^2$
 5. $(y - 5)^2$ 6. $(3y + 1)^2$ 7. $(x + y)^2$ 8. $(2x + y)^2$
 9. $(a - b)^2$ 10. $(2a - 3b)^2$ 11. $3(x + 2)^2$ 12. $(3 - x)^2$
 13. $(3x + 2)^2$ 14. $(a - 2b)^2$ 15. $(x + 1)^2 + (x + 2)^2$ 16. $(x - 2)^2 + (x + 3)^2$
 17. $(x + 2)^2 + (2x + 1)^2$ 18. $(y - 3)^2 + (y - 4)^2$ 19. $(x + 2)^2 - (x - 3)^2$ 20. $(x - 3)^2 - (x + 1)^2$
 21. $(y - 3)^2 - (y + 2)^2$ ✓ 22. $(2x + 1)^2 - (x + 3)^2$ ✓ 23. $3(x + 2)^2 - (x + 4)^2$ 24. $2(x - 3)^2 - 3(x + 1)^2$

2.4 Linear equations

- If the x term is negative, take it to the other side, where it becomes positive.

Example 1

$$\begin{aligned}
 4 - 3x &= 2 \\
 4 &= 2 + 3x \\
 2 &= 3x \\
 \frac{2}{3} &= x
 \end{aligned}$$

- If there are x terms on both sides, collect them on one side.

Example 2

$$\begin{aligned}
 2x - 7 &= 5 - 3x \\
 2x + 3x &= 5 + 7 \\
 5x &= 12 \\
 x &= \frac{12}{5} = 2\frac{2}{5}
 \end{aligned}$$

- If there is a fraction in the x term, multiply out to simplify the equation.

Example 3

$$\frac{2x}{3} = 10$$

$$2x = 30$$

$$x = \frac{30}{2} = 15$$

Exercise 11

Solve the following equations:

✓ 1. $2x - 5 = 11$

2. $3x - 7 = 20$

3. $2x + 6 = 20$

4. $5x + 10 = 60$

5. $8 = 7 + 3x$

6. $12 = 2x - 8$

7. $-7 = 2x - 10$

8. $3x - 7 = -10$

9. $12 = 15 + 2x$

10. $5 + 6x = 7$

11. $\frac{x}{5} = 7$

12. $\frac{x}{10} = 13$

13. $7 = \frac{x}{2}$

14. $\frac{x}{2} = \frac{1}{3}$

15. $\frac{3x}{2} = 5$

16. $\frac{4x}{5} = -2$

17. $7 = \frac{7x}{3}$

18. $\frac{3}{4} = \frac{2x}{3}$

19. $\frac{5x}{6} = \frac{1}{4}$

20. $-\frac{3}{4} = \frac{3x}{5}$

21. $\frac{x}{2} + 7 = 12$

22. $\frac{x}{3} - 7 = 2$

23. $\frac{x}{5} - 6 = -2$

24. $4 = \frac{x}{2} - 5$

25. $10 = 3 + \frac{x}{4}$

26. $\frac{a}{5} - 1 = -4$

27. $100x - 1 = 98$

28. $7 = 7 + 7x$

29. $\frac{x}{100} + 10 = 20$

30. $1000x - 5 = -6$

31. $-4 = -7 + 3x$

32. $2x + 4 = x - 3$

33. $x - 3 = 3x + 7$

34. $5x - 4 = 3 - x$

35. $4 - 3x = 1$

36. $5 - 4x = -3$

✓ 37. $7 = 2 - x$

38. $3 - 2x = x + 12$

39. $6 + 2a = 3$

40. $a - 3 = 3a - 7$

41. $2y - 1 = 4 - 3y$

42. $7 - 2x = 2x - 7$

43. $7 - 3x = 5 - 2x$

✓ 44. $8 - 2y = 5 - 5y$

✓ 45. $x - 16 = 16 - 2x$

46. $x + 2 = 3 \cdot 1$

✓ 47. $-x - 4 = -3$

48. $-3 - x = -5$

49. $-\frac{x}{2} + 1 = -\frac{1}{4}$

50. $-\frac{3}{5} + \frac{x}{10} = -\frac{1}{5} - \frac{x}{5}$

Example

$$x - 2(x - 1) = 1 - 4(x + 1)$$

$$x - 2x + 2 = 1 - 4x - 4$$

$$x - 2x + 4x = 1 - 4 - 2$$

$$3x = -5$$

$$x = -\frac{5}{3}$$

Exercise 12

Solve the following equations:

- ✓ 1. $x + 3(x + 1) = 2x$
 3. $2x - 2(x + 1) = 5x$
 5. $4(x - 1) = 2(3 - x)$
 7. $4(1 - 2x) = 3(2 - x)$
 9. $4x = x - (x - 2)$
 11. $5x - 3(x - 1) = 39$
 13. $7 - (x + 1) = 9 - (2x - 1)$
 15. $3(2x + 1) + 2(x - 1) = 23$
 17. $7x - (2 - x) = 0$
 ✓ 19. $3y + 7 + 3(y - 1) = 2(2y + 6)$
 21. $4x - 2(x + 1) = 5(x + 3) + 5$
 23. $10(2x + 3) - 8(3x - 5) + 5(2x - 8) = 0$
 ✓ 25. $7(2x - 4) + 3(5 - 3x) = 2$
 27. $5(2x - 1) - 2(x - 2) = 7 + 4x$
 29. $3(x - 3) - 7(2x - 8) - (x - 1) = 0$
 31. $6x + 30(x - 12) = 2(x - 1\frac{1}{2})$
 33. $5(x - 1) + 17(x - 2) = 2x + 1$
 35. $7(x + 4) - 5(x + 3) + (4 - x) = 0$
 ✓ 37. $10(2 \cdot 3 - x) - 0 \cdot 1(5x - 30) = 0$
 39. $(6 - x) - (x - 5) - (4 - x) = -\frac{x}{2}$
- ✓ 2. $1 + 3(x - 1) = 4$
 4. $2(3x - 1) = 3(x - 1)$
 6. $4(x - 1) - 2 = 3x$
 8. $3 - 2(2x + 1) = x + 17$
 10. $7x = 3x - (x + 20)$
 12. $3x + 2(x - 5) = 15$
 ✓ 14. $10x - (2x + 3) = 21$
 16. $5(1 - 2x) - 3(4 + 4x) = 0$
 18. $3(x + 1) = 4 - (x - 3)$
 20. $4(y - 1) + 3(y + 2) = 5(y - 4)$
 22. $7 - 2(x - 1) = 3(2x - 1) + 2$
 24. $2(x + 4) + 3(x - 10) = 8$
 ✓ 26. $10(x + 4) - 9(x - 3) - 1 = 8(x + 3)$
 28. $6(3x - 4) - 10(x - 3) = 10(2x - 3)$
 30. $5 + 2(x + 5) = 10 - (4 - 5x)$
 32. $3(2x - \frac{2}{3}) - 7(x - 1) = 0$
 34. $6(2x - 1) + 9(x + 1) = 8(x - 1\frac{1}{4})$
 36. $0 = 9(3x + 7) - 5(x + 2) - (2x - 5)$
 38. $8(2\frac{1}{2}x - \frac{3}{4}) - \frac{1}{4}(1 - x) = \frac{1}{2}$
 ✓ 40. $10\left(1 - \frac{x}{10}\right) - (10 - x) - \frac{1}{100}(10 - x) = 0.05$

Example

$$\begin{aligned}
 (x + 3)^2 &= (x + 2)^2 + 3^2 \\
 (x + 3)(x + 3) &= (x + 2)(x + 2) + 9 \\
 x^2 + 6x + 9 &= x^2 + 4x + 4 + 9 \\
 6x + 9 &= 4x + 13 \\
 2x &= 4 \\
 x &= 2
 \end{aligned}$$

Exercise 13

Solve the following equations:

1. $x^2 + 4 = (x + 1)(x + 3)$
 3. $(x + 3)(x - 1) = x^2 + 5$
 5. $(x - 2)(x + 3) = (x - 7)(x + 7)$
 7. $2x^2 + 3x = (2x - 1)(x + 1)$
 9. $x^2 + (x + 1)^2 = (2x - 1)(x + 4)$
 11. $(x + 1)(x - 3) + (x + 1)^2 = 2x(x - 4)$
 13. $(x + 2)^2 - (x - 3)^2 = 3x - 11$
 15. $(2x + 1)^2 - 4(x - 3)^2 = 5x + 10$
2. $x^2 + 3x = (x + 3)(x + 1)$
 4. $(x + 1)(x + 4) = (x - 7)(x + 6)$
 6. $(x - 5)(x + 4) = (x + 7)(x - 6)$
 8. $(2x - 1)(x - 3) = (2x - 3)(x - 1)$
 10. $x(2x + 6) = 2(x^2 - 5)$
 12. $(2x + 1)(x - 4) + (x - 2)^2 = 3x(x + 2)$
 14. $x(x - 1) = 2(x - 1)(x + 5) - (x - 4)^2$
 16. $2(x + 1)^2 - (x - 2)^2 = x(x - 3)$

17. The area of the rectangle shown exceeds the area of the square by 2 cm^2 . Find x .

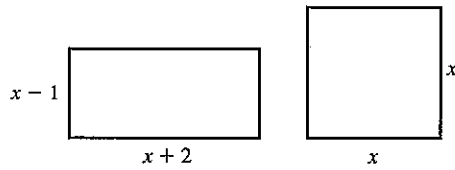

18. The area of the square exceeds the area of the rectangle by 13 m^2 . Find y .

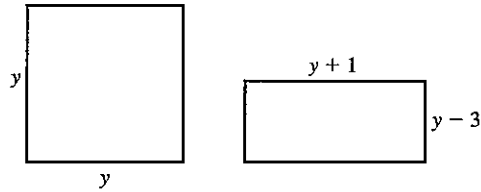

Remember
For a rectangle:
Area = length \times width

19. The area of the square is half the area of the rectangle. Find x .



When solving equations involving fractions, multiply both sides of the equation by a suitable number to eliminate the fractions.

Example 1

$$\frac{5}{x} = 2$$

$$5 = 2x \quad (\text{multiply both sides by } x)$$

$$\frac{5}{2} = x$$

Example 2

$$\frac{x+4}{4} = \frac{2x-1}{3} \quad \dots(\text{A})$$

$$12 \frac{(x+3)}{4} = 12 \frac{(2x-1)}{3}$$

(multiply both sides by 12)

$$\therefore 3(x+3) = 4(2x-1) \quad \dots(\text{B})$$

$$3x+9 = 8x-4$$

$$13 = 5x$$

$$\frac{13}{5} = x$$

$$x = 2\frac{3}{5}$$

Note: It is possible to go straight from line (A) to line (B) by 'cross-multiplying'.

Example 3

$$\frac{5}{(x-1)} + 2 = 12$$

$$\frac{5}{(x-1)} = 10$$

$$5 = 10(x-1)$$

$$5 = 10x - 10$$

$$15 = 10x$$

$$\frac{15}{10} = x$$

$$x = 1\frac{1}{2}$$

Exercise 14

Solve the following equations:

1. $\frac{7}{x} = 21$

4. $\frac{9}{x} = -3$

7. $\frac{x}{4} = \frac{3}{2}$

10. $\frac{x+3}{2} = \frac{x-4}{5}$

13. $\frac{8-x}{2} = \frac{2x+2}{5}$

16. $\frac{2}{x-1} = 1$

19. $\frac{x}{2} - \frac{x}{5} = 3$

2. $30 = \frac{6}{x}$

5. $11 = \frac{5}{x}$

8. $\frac{x}{3} = 1\frac{1}{4}$

11. $\frac{2x-1}{3} = \frac{x}{2}$

14. $\frac{x+2}{7} = \frac{3x+6}{5}$

17. $\frac{x}{3} + \frac{x}{4} = 1$

20. $\frac{x}{3} = 2 + \frac{x}{4}$

3. $\frac{5}{x} = 3$

6. $-2 = \frac{4}{x}$

9. $\frac{x+1}{3} = \frac{x-1}{4}$

12. $\frac{3x+1}{5} = \frac{2x}{3}$

15. $\frac{1-x}{2} = \frac{3-x}{3}$

18. $\frac{x}{3} + \frac{x}{2} = 4$

21. $\frac{5}{x-1} = \frac{10}{x}$

22. $\frac{12}{2x-3} = 4$

25. $\frac{9}{x} = \frac{5}{x-3}$

28. $\frac{4}{x+1} = \frac{7}{3x-2}$

31. $\frac{1}{2}(x-1) - \frac{1}{6}(x+1) = 0$

34. $\frac{6}{x} - 3 = 7$

37. $4 - \frac{4}{x} = 0$

40. $4 + \frac{5}{3x} = -1$

43. $\frac{x-1}{4} - \frac{2x-3}{5} = \frac{1}{20}$

46. $\frac{2x+1}{8} - \frac{x-1}{3} = \frac{5}{24}$

23. $2 = \frac{18}{x+4}$

26. $\frac{4}{x-1} = \frac{10}{3x-1}$

29. $\frac{x+1}{2} + \frac{x-1}{3} = \frac{1}{6}$

32. $\frac{1}{4}(x+5) - \frac{2x}{3} = 0$

35. $\frac{9}{x} - 7 = 1$

38. $5 - \frac{6}{x} = -1$

41. $\frac{9}{2x} - 5 = 0$

44. $\frac{4}{1-x} = \frac{3}{1+x}$

24. $\frac{5}{x+5} = \frac{15}{x+7}$

27. $\frac{-7}{x-1} = \frac{14}{5x+2}$

30. $\frac{1}{3}(x+2) = \frac{1}{5}(3x+2)$

33. $\frac{4}{x} + 2 = 3$

36. $-2 = 1 + \frac{3}{x}$

39. $7 - \frac{3}{2x} = 1$

42. $\frac{x-1}{5} - \frac{x-1}{3} = 0$

45. $\frac{x+1}{4} - \frac{x}{3} = \frac{1}{12}$

2.5 Problems solved by linear equations

- Let the unknown quantity be x (or any other letter) and state the units (where appropriate).
- Express the given statement in the form of an equation.
- Solve the equation for x and give the answer in *words*. (Do not finish by writing ' $x = 3$ '.)
- Check your solution using the problem (not your equation).

Example 1

The sum of three consecutive whole numbers is 78. Find the numbers.

- (a) Let the smallest number be x ; then the other numbers are $(x+1)$ and $(x+2)$.
- (b) Form an equation:
 $x + (x+1) + (x+2) = 78$
- (c) Solve: $3x = 75$
 $x = 25$
 In words:
 The three numbers are 25, 26 and 27.
- (d) Check: $25 + 26 + 27 = 78$

Example 2

The length of a rectangle is three times the width. If the perimeter is 36 cm, find the width.

- (a) Let the width of the rectangle be x cm.
Then the length of the rectangle is $3x$ cm.

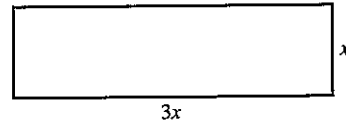

- (b) Form an equation.
 $x + 3x + x + 3x = 36$

- (c) Solve: $8x = 36$
 $x = \frac{36}{8}$
 $x = 4.5$

In words:

The width of the rectangle is 4.5 cm.

- (d) Check: If width = 4.5 cm
length = 13.5 cm
perimeter = 36 cm

Exercise 15

Solve each problem by forming an equation. The first questions are easy but should still be solved using an equation, in order to practise the method:

1. The sum of three consecutive numbers is 276. Find the numbers.
2. The sum of four consecutive numbers is 90. Find the numbers.
3. The sum of three consecutive odd numbers is 177. Find the numbers.
4. Find three consecutive even numbers which add up to 1524.
5. When a number is doubled and then added to 13, the result is 38. Find the number.
6. When a number is doubled and then added to 24, the result is 49. Find the number.
7. When 7 is subtracted from three times a certain number, the result is 28. What is the number?
8. The sum of two numbers is 50. The second number is five times the first. Find the numbers.
9. Two numbers are in the ratio 1 : 11 and their sum is 15. Find the numbers.
10. The length of a rectangle is twice the width. If the perimeter is 20 cm, find the width.

11. The width of a rectangle is one third of the length. If the perimeter is 96 cm, find the width.
12. If AB is a straight line, find x .
(The angles on a straight line add to 180° .)

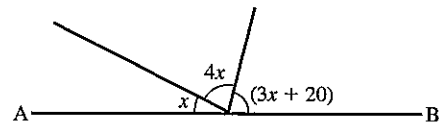

13. If the perimeter of the triangle is 22 cm, find the length of the shortest side.

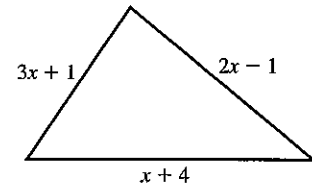

14. If the perimeter of the rectangle is 34 cm, find x .

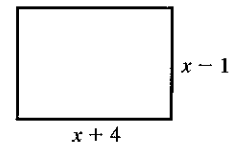

15. The difference between two numbers is 9.
Find the numbers, if their sum is 46.
16. The three angles in a triangle are in the ratio 1 : 3 : 5. Find them.

Angles in a triangle add to 180° .

17. The three angles in a triangle are in the ratio 3 : 4 : 5. Find them.
18. The product of two consecutive odd numbers is 10 more than the square of the smaller number. Find the smaller number.
19. The product of two consecutive even numbers is 12 more than the square of the smaller number. Find the numbers.
20. The sum of three numbers is 66. The second number is twice the first and six less than the third. Find the numbers.
21. The sum of three numbers is 28. The second number is three times the first and the third is 7 less than the second. What are the numbers?
22. David weighs 5 kg less than John, who in turn is 8 kg lighter than Paul. If their total weight is 197 kg, how heavy is each person?
23. Brian is 2 years older than Bob who is 7 years older than Mark. If their combined age is 61 years, find the age of each person.
24. Richard has four times as many marbles as John. If Richard gave 18 to John they would have the same number. How many marbles has each?
25. Stella has five times as many books as Tina.
If Stella gave 16 books to Tina, they would each have the same number. How many books did each girl have?

26. The result of trebling a number is the same as adding 12 to it. What is the number?
27. Find the area of the rectangle if the perimeter is 52 cm.
(The perimeter is the distance around the edge of the rectangle.)

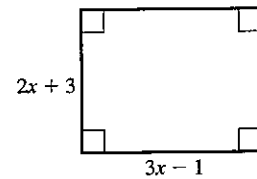

28. The result of trebling a number and subtracting 5 is the same as doubling the number and adding 9. What is the number?
29. Two girls have \$76 between them. If the first gave the second \$7 they would each have the same amount of money. How much did each girl have?
30. A tennis racket costs \$12 more than a hockey stick. If the price of the two is \$31, find the cost of the tennis racket.

Example

A man goes out at 16:42 and arrives at a post box, 6 km away, at 17:30. He walked part of the way at 5 km/h and then, realising the time, he ran the rest of the way at 10 km/h. How far did he have to run?

- Let the distance he ran be x km. Then the distance he walked = $(6 - x)$ km.
- Time taken to walk $(6 - x)$ km at 5 km/h = $\frac{(6 - x)}{5}$ hours.

$$\text{Time taken to run } x \text{ km at } 10 \text{ km/h} = \frac{x}{10} \text{ hours.}$$

$$\text{Total time taken} = 48 \text{ minutes}$$

$$= \frac{4}{5} \text{ hour}$$

$$\therefore \frac{(6 - x)}{5} + \frac{x}{10} = \frac{4}{5}$$

- Multiply by 10:

$$2(6 - x) + x = 8$$

$$12 - 2x + x = 8$$

$$4 = x$$

He ran a distance of 4 km.

- Check:

$$\text{Time to run } 4 \text{ km} = \frac{4}{10} = \frac{2}{5} \text{ hour.}$$

$$\text{Time to walk } 2 \text{ km} = \frac{2}{5} \text{ hour.}$$

$$\text{Total time taken} = \left(\frac{2}{5} + \frac{2}{5} \right) \text{ h} = \frac{4}{5} \text{ h}$$

Exercise 16

1. Every year a man is paid \$500 more than the previous year. If he receives \$17 800 over four years, what was he paid in the first year?
2. A man buys x cans of beer at 30 cents each and $(x + 4)$ cans of lager at 35 cents each. The total cost was \$3.35. Find x .
3. The length of a straight line ABC is 5 m. If $AB : BC = 2 : 5$, find the length of AB.
4. The opposite angles of a cyclic quadrilateral are $(3x + 10)^\circ$ and $(2x + 20)^\circ$. Find the angles.
5. The interior angles of a hexagon are in the ratio $1 : 2 : 3 : 4 : 5 : 9$. Find the angles. This is an example of a concave hexagon. Try to sketch the hexagon.
6. A man is 32 years older than his son. Ten years ago he was three times as old as his son was then. Find the present age of each.
7. A man runs to a telephone and back in 15 minutes. His speed on the way to the telephone is 5 m/s and his speed on the way back is 4 m/s. Find the distance to the telephone.
8. A car completes a journey in 10 minutes. For the first half of the distance the speed was 60 km/h and for the second half the speed was 40 km/h. How far is the journey?
9. A lemming runs from a point A to a cliff at 4 m/s, jumps over the edge at B and falls to C at an average speed of 25 m/s. If the total distance from A to C is 500 m and the time taken for the journey is 41 seconds, find the height BC of the cliff.
10. A bus is travelling with 48 passengers. When it arrives at a stop, x passengers get off and 3 get on. At the next stop half the passengers get off and 7 get on. There are now 22 passengers. Find x .
11. A bus is travelling with 52 passengers. When it arrives at a stop, y passengers get off and 4 get on. At the next stop one-third of the passengers get off and 3 get on. There are now 25 passengers. Find y .
12. Mr Lee left his fortune to his 3 sons, 4 daughters and his wife. Each son received twice as much as each daughter and his wife received \$6000, which was a quarter of the money. How much did each son receive?
13. In a regular polygon with n sides each interior angle is $180 - \frac{360}{n}$ degrees. How many sides does a polygon have if each interior angle is 156° ?

Opposite angles of a cyclic quadrilateral add to 180° .

Interior angles of a hexagon add to 720° .

14. A sparrow flies to see a friend at a speed of 4 km/h. His friend is out, so the sparrow immediately returns home at a speed of 5 km/h. The complete journey took 54 minutes. How far away does his friend live?
15. Consider the equation $an^2 = 182$ where a is any number between 2 and 5 and n is a positive integer. What are the possible values of n ?
16. Consider the equation $\frac{k}{x} = 12$ where k is any number between 20 and 65 and x is a positive integer. What are the possible values of x ?

2.6 Simultaneous equations

To find the value of two unknowns in a problem, *two* different equations must be given that relate the unknowns to each other. These two equations are called *simultaneous* equations.

Substitution method

This method is used when one equation contains a unit quantity of one of the unknowns, as in equation [2] of the example below.

Example

$$\begin{array}{r} 3x - 2y = 0 \qquad \dots [1] \\ 2x + y = 7 \qquad \dots [2] \end{array}$$

- (a) Label the equations so that the working is made clear.
 (b) In *this* case, write y in terms of x from equation [2].
 (c) Substitute this expression for y in equation [1] and solve to find x .
 (d) Find y from equation [2] using this value of x .

$$\begin{array}{r} 2x + y = 7 \qquad \dots [2] \\ y = 7 - 2x \end{array}$$

Substituting in [1]

$$\begin{array}{r} 3x - 2(7 - 2x) = 0 \\ 3x - 14 + 4x = 0 \\ 7x = 14 \\ x = 2 \end{array}$$

Substituting in [2]

$$\begin{array}{r} 2 \times 2 + y = 7 \\ y = 3 \end{array}$$

The solutions are $x = 2$, $y = 3$.

These values of x and y are the only pair which simultaneously satisfy *both* equations.

Exercise 17

Use the substitution method to solve the following:

- | | | |
|--|---|--|
| 1. $2x + y = 5$
$x + 3y = 5$ | 2. $x + 2y = 8$
$2x + 3y = 14$ | 3. $3x + y = 10$
$x - y = 2$ |
| 4. $2x + y = -3$
$x - y = -3$ | 5. $4x + y = 14$
$x + 5y = 13$ | 6. $x + 2y = 1$
$2x + 3y = 4$ |
| 7. $2x + y = 5$
$3x - 2y = 4$ | 8. $2x + y = 13$
$5x - 4y = 13$ | 9. $7x + 2y = 19$
$x - y = 4$ |
| 10. $b - a = -5$
$a + b = -1$ | 11. $a + 4b = 6$
$8b - a = -3$ | 12. $a + b = 4$
$2a + b = 5$ |
| 13. $3m = 2n - 6\frac{1}{2}$
$4m + n = 6$ | 14. $2w + 3x - 13 = 0$
$x + 5w - 13 = 0$ | 15. $x + 2(y - 6) = 0$
$3x + 4y = 30$ |
| 16. $2x = 4 + z$
$6x - 5z = 18$ | 17. $3m - n = 5$
$2m + 5n = 7$ | 18. $5c - d - 11 = 0$
$4d + 3c = -5$ |

It is useful, at this point to revise the operations of addition and subtraction with negative numbers.

Example

Simplify:

- (a) $-7 + -4 = -7 - 4 = -11$
 (b) $-3x + (-4x) = -3x - 4x = -7x$
 (c) $4y - (-3y) = 4y + 3y = 7y$
 (d) $3a + (-3a) = 3a - 3a = 0$

Exercise 18

Evaluate:

- | | | |
|------------------|------------------|------------------|
| 1. $7 + (-6)$ | 2. $8 + (-11)$ | 3. $5 - (+7)$ |
| 4. $6 - (-9)$ | 5. $-8 + (-4)$ | 6. $-7 - (-4)$ |
| 7. $10 + (-12)$ | 8. $-7 - (+4)$ | 9. $-10 - (+11)$ |
| 10. $-3 - (-4)$ | 11. $4 - (+4)$ | 12. $8 - (-7)$ |
| 13. $-5 - (+5)$ | 14. $-7 - (-10)$ | 15. $16 - (+10)$ |
| 16. $-7 - (+4)$ | 17. $-6 - (-8)$ | 18. $10 - (+5)$ |
| 19. $-12 + (-7)$ | 20. $7 + (-11)$ | |

Simplify:

- | | | |
|--------------------|-------------------|------------------|
| 21. $3x + (-2x)$ | 22. $4x + (-7x)$ | 23. $6x - (+2x)$ |
| 24. $10y - (+6y)$ | 25. $6y - (-3y)$ | 26. $7x + (-4x)$ |
| 27. $-5x + (-3x)$ | 28. $-3x - (-7x)$ | 29. $5x - (+3x)$ |
| 30. $-7y - (-10y)$ | | |

Elimination method

Use this method when the first method is unsuitable (some prefer to use it for every question).

Example 1

$$\begin{array}{r} x + 2y = 8 \quad \dots [1] \\ 2x + 3y = 14 \quad \dots [2] \end{array}$$

- Label the equations so that the working is made clear.
- Choose an unknown in one of the equations and multiply the equations by a factor or factors so that this unknown has the same coefficient in both equations.
- Eliminate this unknown from the two equations by subtracting them, then solve for the remaining unknown.
- Substitute in the first equation and solve for the eliminated unknown.

$$\begin{array}{r} x + 2y = 8 \quad \dots [1] \\ [1] \times 2 \quad 2x + 4y = 16 \quad \dots [3] \\ \quad \quad 2x + 3y = 14 \quad \dots [2] \end{array}$$

$$\begin{array}{l} \text{Subtract [2] from [3]} \\ y = 2 \end{array}$$

$$\begin{array}{l} \text{Substituting in [1]} \\ x + 2 \times 2 = 8 \\ x = 8 - 4 \\ x = 4 \end{array}$$

The solutions are $x = 4$, $y = 2$.

Example 2

$$\begin{array}{r} 2x + 3y = 5 \quad \dots [1] \\ 5x - 2y = -16 \quad \dots [2] \\ [1] \times 5 \quad 10x + 15y = 25 \quad \dots [3] \\ [2] \times 2 \quad 10x - 4y = -32 \quad \dots [4] \\ [3] - 4 \quad 15y - (-4y) = 25 - (-32) \\ \quad \quad 19y = 57 \\ \quad \quad y = 3 \end{array}$$

$$\begin{array}{l} \text{Substitute in [1]} \\ 2x + 3 \times 3 = 5 \\ 2x = 5 - 9 = -4 \\ x = -2 \end{array}$$

The solutions are $x = -2$, $y = 3$.

Exercise 19

Use the elimination method to solve the following:

- | | | |
|--|--|--|
| 1. $2x + 5y = 24$
$4x + 3y = 20$ | 2. $5x + 2y = 13$
$2x + 6y = 26$ | 3. $3x + y = 11$
$9x + 2y = 28$ |
| 4. $x + 2y = 17$
$8x + 3y = 45$ | 5. $3x + 2y = 19$
$x + 8y = 21$ | 6. $2a + 3b = 9$
$4a + b = 13$ |
| 7. $2x + 3y = 11$
$3x + 4y = 15$ | 8. $3x + 8y = 27$
$4x + 3y = 13$ | 9. $2x + 7y = 17$
$5x + 3y = -1$ |
| 10. $5x + 3y = 23$
$2x + 4y = 12$ | 11. $7x + 5y = 32$
$3x + 4y = 23$ | 12. $3x + 2y = 4$
$4x + 5y = 10$ |
| 13. $3x + 2y = 11$
$2x - y = -3$ | 14. $3x + 2y = 7$
$2x - 3y = -4$ | 15. $x + 2y = -4$
$3x - y = 9$ |
| 16. $5x - 7y = 27$
$3x - 4y = 16$ | 17. $3x - 2y = 7$
$4x + y = 13$ | 18. $x - y = -1$
$2x - y = 0$ |
| 19. $y - x = -1$
$3x - y = 5$ | 20. $x - 3y = -5$
$2y + 3x + 4 = 0$ | 21. $x + 3y - 7 = 0$
$2y - x - 3 = 0$ |
| 22. $3a - b = 9$
$2a + 2b = 14$ | 23. $3x - y = 9$
$4x - y = -14$ | 24. $x + 2y = 4$
$3x + y = 9\frac{1}{2}$ |
| 25. $2x - y = 5$
$\frac{x}{4} + \frac{y}{3} = 2$ | 26. $3x - y = 17$
$\frac{x}{5} + \frac{y}{2} = 0$ | 27. $3x - 2y = 5$
$\frac{2x}{3} + \frac{y}{2} = -\frac{7}{9}$ |
| 28. $2x = 11 - y$
$\frac{x}{5} - \frac{y}{4} = 1$ | 29. $4x - 0.5y = 12.5$
$3x + 0.8y = 8.2$ | 30. $0.4x + 3y = 2.6$
$x - 2y = 4.6$ |

2.7 Problems solved by simultaneous equations**Example**

A motorist buys 24 litres of petrol and 5 litres of oil for \$10.70, while another motorist buys 18 litres of petrol and 10 litres of oil for \$12.40. Find the cost of 1 litre of petrol and 1 litre of oil at this garage.

Let cost of 1 litre of petrol be x cents.Let cost of 1 litre of oil be y cents.

$$\begin{array}{l} \text{We have, } 24x + 5y = 1070 \quad \dots [1] \\ 18x + 10y = 1240 \quad \dots [2] \end{array}$$

(a) Multiply [1] by 2,
 $48x + 10y = 2140 \quad \dots [3]$

(b) Subtract [2] from [3],
 $30x = 900$
 $x = 30$

(c) Substitute $x = 30$ into equation [2]
 $18(30) + 10y = 1240$
 $10y = 1240 - 540$
 $10y = 700$
 $y = 70$

1 litre of petrol costs 30 cents and
1 litre of oil costs 70 cents.

Exercise 20

Solve each problem by forming a pair of simultaneous equations:

1. Find two numbers with a sum of 15 and a difference of 4.
2. Twice one number added to three times another gives 21. Find the numbers, if the difference between them is 3.
3. The average of two numbers is 7, and three times the difference between them is 18. Find the numbers.
4. The line, with equation $y + ax = c$, passes through the points (1, 5) and (3, 1). Find a and c .
Hint: For the point (1, 5) put $x = 1$ and $y = 5$ into $y + ax = c$, etc.
5. The line $y = mx + c$ passes through (2, 5) and (4, 13). Find m and c .
6. The curve $y = ax^2 + bx$ passes through (2, 0) and (4, 8). Find a and b .
7. A fishing enthusiast buys fifty maggots and twenty worms for \$1.10 and her mother buys thirty maggots and forty worms for \$1.50. Find the cost of one maggot and one worm.
8. A television addict can buy either two televisions and three video-recorders for \$1750 or four televisions and one video-recorder for \$1250. Find the cost of one of each.
9. Half the difference between two numbers is 2. The sum of the greater number and twice the smaller number is 13. Find the numbers.
10. A snake can lay either white or brown eggs. Three white eggs and two brown eggs weigh 13 grams, while five white eggs and four brown eggs weigh 24 grams. Find the weight of a brown egg and of a white egg.
11. A tortoise makes a journey in two parts; it can either walk at 4 cm/s or crawl at 3 cm/s. If the tortoise walks the first part and crawls the second, it takes 110 seconds. If it crawls the first part and walks the second, it takes 100 seconds. Find the lengths of the two parts of the journey.
12. A cyclist completes a journey of 500 m in 22 seconds, part of the way at 10 m/s and the remainder at 50 m/s. How far does she travel at each speed?
13. A bag contains forty coins, all of them either 2 cent or 5 cent coins. If the value of the money in the bag is \$1.55, find the number of each kind.
14. A slot machine takes only 10 cent and 50 cent coins and contains a total of twenty-one coins altogether. If the value of the coins is \$4.90, find the number of coins of each value.
15. Thirty tickets were sold for a concert, some at 60 cents and the rest at \$1. If the total raised was \$22, how many had the cheaper tickets?

Remember
100 cents = \$1

16. The wage bill for five men and six women workers is \$6700, while the bill for eight men and three women is \$6100. Find the wage for a man and for a woman.
17. A fish can swim at 14 m/s with the current and at 6 m/s against it. Find the speed of the current and the speed of the fish in still water.
18. If the numerator and denominator of a fraction are both decreased by one the fraction becomes $\frac{2}{3}$. If the numerator and denominator are both increased by one the fraction becomes $\frac{3}{4}$. Find the original fraction.
19. The denominator of a fraction is 2 more than the numerator. If both denominator and numerator are increased by 1 the fraction becomes $\frac{2}{3}$. Find the original fraction.
20. In three years' time a pet mouse will be as old as his owner was four years ago. Their present ages total 13 years. Find the age of each now.
21. Find two numbers where three times the smaller number exceeds the larger by 5 and the sum of the numbers is 11.
22. A straight line passes through the points (2, 4) and (-1, -5). Find its equation.
23. A spider can walk at a certain speed and run at another speed. If she walks for 10 seconds and runs for 9 seconds she travels 85 m. If she walks for 30 seconds and runs for 2 seconds she travels 130 m. Find her speeds of walking and running.
24. A wallet containing \$40 has three times as many \$1 notes as \$5 notes. Find the number of each kind.
25. At the present time a man is four times as old as his son. Six years ago he was 10 times as old. Find their present ages.
26. A submarine can travel at 25 knots with the wind and at 16 knots against it. Find the speed of the wind and the speed of the submarine in still air.
27. The curve $y = ax^2 + bx + c$ passes through the points (1, 8), (0, 5) and (3, 20). Find the values of a , b and c and hence the equation of the curve.
28. The curve $y = ax^2 + bx + c$ passes through the points (1, 4), (-2, 19) and (0, 5). Find the equation of the curve.
29. The curve $y = ax^2 + bx + c$ passes through (1, 8), (-1, 2) and (2, 14). Find the equation of the curve.
30. The curve $y = ax^2 + bx + c$ passes through (2, 5), (3, 12) and (-1, -4). Find the equation of the curve.

2.8 Factorising

Earlier in this section we expanded expressions such as $x(3x - 1)$ to give $3x^2 - x$.

The reverse of this process is called *factorising*.

Example

Factorise: (a) $x^2 + 7x$ (b) $3y^2 - 12y$ (c) $6a^2b - 10ab^2$

(a) x is common to x^2 and $7x$.

$$\therefore x^2 + 7x = x(x + 7)$$

The factors are x and $(x + 7)$.

(b) $3y$ is common.

$$\therefore 3y^2 - 12y = 3y(y - 4)$$

(c) $2ab$ is common.

$$\therefore 6a^2b - 10ab^2 = 2ab(3a - 5b)$$

Exercise 21

Factorise the following expressions completely:

- | | | | |
|------------------------|-------------------------|----------------------------|----------------------------|
| 1. $x^2 + 5x$ | 2. $x^2 - 6x$ | 3. $7x - x^2$ | 4. $y^2 + 8y$ |
| 5. $2y^2 + 3y$ | 6. $6y^2 - 4y$ | 7. $3x^2 - 21x$ | 8. $16a - 2a^2$ |
| 9. $6c^2 - 21c$ | 10. $15x - 9x^2$ | 11. $56y - 21y^2$ | 12. $ax + bx + 2cx$ |
| 13. $x^2 + xy + 3xz$ | 14. $x^2y + y^3 + z^2y$ | 15. $3a^2b + 2ab^2$ | 16. $x^2y + xy^2$ |
| 17. $6a^2 + 4ab + 2ac$ | 18. $ma + 2bm + m^2$ | 19. $2kx + 6ky + 4kz$ | 20. $ax^2 + ay + 2ab$ |
| 21. $x^2k + xk^2$ | 22. $a^3b + 2ab^2$ | 23. $abc - 3b^2c$ | 24. $2a^2e - 5ae^2$ |
| 25. $a^3b + ab^3$ | 26. $x^3y + x^2y^2$ | 27. $6xy^2 - 4x^2y$ | 28. $3ab^3 - 3a^3b$ |
| 29. $2a^3b + 5a^2b^2$ | 30. $ax^2y - 2ax^2z$ | 31. $2abx + 2ab^2 + 2a^2b$ | 32. $ayx + yx^3 - 2y^2x^2$ |

Example 1

Factorise $ah + ak + bh + bk$.

(a) Divide into pairs, $ah + ak$ | $bh + bk$.

(b) a is common to the first pair
 b is common to the second pair
 $a(h + k) + b(h + k)$

(c) $(h + k)$ is common to both terms.
 Thus we have $(h + k)(a + b)$

Example 2

Factorise $6mx - 3nx + 2my - ny$.

(a) $6mx - 3nx$ | $2my - ny$

(b) $= 3x(2m - n) + y(2m - n)$

(c) $= (2m - n)(3x + y)$

Exercise 22

Factorise the following expressions:

- | | | |
|---------------------------|-----------------------------|-------------------------------|
| 1. $ax + ay + bx + by$ | 2. $ay + az + by + bz$ | 3. $xb + xc + yb + yc$ |
| 4. $xh + xk + yh + yk$ | 5. $xm + xn + my + ny$ | 6. $ah - ak + bh - bk$ |
| 7. $ax - ay + bx - by$ | 8. $am - bm + an - bn$ | 9. $hs + ht + ks + kt$ |
| 10. $xs - xt + ys - yt$ | 11. $ax - ay - bx + by$ | 12. $xs - xt - ys + yt$ |
| 13. $as - ay - xs + xy$ | 14. $hx - hy - bx + by$ | 15. $am - bm - an + bn$ |
| 16. $xk - xm - kz + mz$ | 17. $2ax + 6ay + bx + 3by$ | 18. $2ax + 2ay + bx + by$ |
| 19. $2mh - 2mk + nh - nk$ | 20. $2mh + 3mk - 2nh - 3nk$ | 21. $6ax + 2bx + 3ay + by$ |
| 22. $2ax - 2ay - bx + by$ | 23. $x^2a + x^2b + ya + yb$ | 24. $ms + 2mt^2 - ns - 2nt^2$ |

Example 1Factorise $x^2 + 6x + 8$.

- (a) Find two numbers which multiply to give 8 and add up to 6.
In this case the numbers are 4 and 2.
- (b) Put these numbers into brackets.
So $x^2 + 6x + 8 = (x + 4)(x + 2)$

Example 2Factorise (a) $x^2 + 2x - 15$
(b) $x^2 - 6x + 8$

- (a) Two numbers which multiply to give -15 and add up to $+2$ are -3 and 5 .
 $\therefore x^2 + 2x - 15 = (x - 3)(x + 5)$
- (b) Two numbers which multiply to give $+8$ and add up to -6 are -2 and -4 .
 $\therefore x^2 - 6x + 8 = (x - 2)(x - 4)$

Exercise 23

Factorise the following:

- | | | |
|----------------------|-----------------------|----------------------|
| 1. $x^2 + 7x + 10$ | 2. $x^2 + 7x + 12$ | 3. $x^2 + 8x + 15$ |
| 4. $x^2 + 10x + 21$ | 5. $x^2 + 8x + 12$ | 6. $y^2 + 12y + 35$ |
| 7. $y^2 + 11y + 24$ | 8. $y^2 + 10y + 25$ | 9. $y^2 + 15y + 36$ |
| 10. $a^2 - 3a - 10$ | 11. $a^2 - a - 12$ | 12. $z^2 + z - 6$ |
| 13. $x^2 - 2x - 35$ | 14. $x^2 - 5x - 24$ | 15. $x^2 - 6x + 8$ |
| 16. $y^2 - 5y + 6$ | 17. $x^2 - 8x + 15$ | 18. $a^2 - a - 6$ |
| 19. $a^2 + 14a + 45$ | 20. $b^2 - 4b - 21$ | 21. $x^2 - 8x + 16$ |
| 22. $y^2 + 2y + 1$ | 23. $y^2 - 3y - 28$ | 24. $x^2 - x - 20$ |
| 25. $x^2 - 8x - 240$ | 26. $x^2 - 26x + 165$ | 27. $y^2 + 3y - 108$ |
| 28. $x^2 - 49$ | 29. $x^2 - 9$ | 30. $x^2 - 16$ |

ExampleFactorise $3x^2 + 13x + 4$.

- (a) Find two numbers which multiply to give 12 and add up to 13.
In this case the numbers are 1 and 12.
- (b) Split the '13x' term,
 $3x^2 + x + 12x + 4$
- (c) Factorise in pairs,
 $x(3x + 1) + 4(3x + 1)$
- (d) $(3x + 1)$ is common,
 $(3x + 1)(x + 4)$

Exercise 24

Factorise the following:

- | | | |
|------------------------|-----------------------|------------------------|
| 1. $2x^2 + 5x + 3$ | 2. $2x^2 + 7x + 3$ | 3. $3x^2 + 7x + 2$ |
| 4. $2x^2 + 11x + 12$ | 5. $3x^2 + 8x + 4$ | 6. $2x^2 + 7x + 5$ |
| 7. $3x^2 - 5x - 2$ | 8. $2x^2 - x - 15$ | 9. $2x^2 + x - 21$ |
| 10. $3x^2 - 17x - 28$ | 11. $6x^2 + 7x + 2$ | 12. $12x^2 + 23x + 10$ |
| 13. $3x^2 - 11x + 6$ | 14. $3y^2 - 11y + 10$ | 15. $4y^2 - 23y + 15$ |
| 16. $6y^2 + 7y - 3$ | 17. $6x^2 - 27x + 30$ | 18. $10x^2 + 9x + 2$ |
| 19. $6x^2 - 19x + 3$ | 20. $8x^2 - 10x - 3$ | 21. $12x^2 + 4x - 5$ |
| 22. $16x^2 + 19x + 3$ | 23. $4a^2 - 4a + 1$ | 24. $12x^2 + 17x - 14$ |
| 25. $15x^2 + 44x - 3$ | 26. $48x^2 + 46x + 5$ | 27. $64y^2 + 4y - 3$ |
| 28. $120x^2 + 67x - 5$ | 29. $9x^2 - 1$ | 30. $4a^2 - 9$ |

The difference of two squares

$$x^2 - y^2 = (x - y)(x + y)$$

Remember this result.

ExampleFactorise (a) $4a^2 - b^2$
(b) $3x^2 - 27y^2$

$$\begin{aligned} \text{(a) } 4a^2 - b^2 &= (2a)^2 - b^2 \\ &= (2a - b)(2a + b) \end{aligned}$$

$$\begin{aligned} \text{(b) } 3x^2 - 27y^2 &= 3(x^2 - 9y^2) \\ &= 3[x^2 - (3y)^2] \\ &= 3(x - 3y)(x + 3y) \end{aligned}$$

Exercise 25

Factorise the following:

- | | | | |
|----------------|----------------|------------------------|------------------------|
| 1. $y^2 - a^2$ | 2. $m^2 - n^2$ | 3. $x^2 - t^2$ | 4. $y^2 - 1$ |
| 5. $x^2 - 9$ | 6. $a^2 - 25$ | 7. $x^2 - \frac{1}{4}$ | 8. $x^2 - \frac{1}{9}$ |

- | | | | |
|---------------------------|-----------------------------|-------------------------------|------------------------------|
| 9. $4x^2 - y^2$ | 10. $a^2 - 4b^2$ | 11. $25x^2 - 4y^2$ | 12. $9x^2 - 16y^2$ |
| 13. $x^2 - \frac{y^2}{4}$ | 14. $9m^2 - \frac{4}{9}n^2$ | 15. $16t^2 - \frac{4}{25}s^2$ | 16. $4x^2 - \frac{z^2}{100}$ |
| 17. $x^3 - x$ | 18. $a^3 - ab^2$ | 19. $4x^3 - x$ | 20. $8x^3 - 2xy^2$ |
| 21. $12x^3 - 3xy^2$ | 22. $18m^3 - 8mn^2$ | 23. $5x^2 - 1\frac{1}{4}$ | 24. $50a^3 - 18ab^2$ |
| 25. $12x^2y - 3yz^2$ | 26. $36a^3b - 4ab^3$ | 27. $50a^5 - 8a^3b^2$ | 28. $36x^3y - 225xy^3$ |

Evaluate the following:

- | | | | |
|----------------------------------|---------------------------------|-----------------------------------|-------------------------------------|
| 29. $81^2 - 80^2$ | 30. $102^2 - 100^2$ | 31. $225^2 - 215^2$ | 32. $1211^2 - 1210^2$ |
| 33. $723^2 - 720^2$ | 34. $3 \cdot 8^2 - 3 \cdot 7^2$ | 35. $5 \cdot 24^2 - 4 \cdot 76^2$ | 36. $1234^2 - 1235^2$ |
| 37. $3 \cdot 81^2 - 3 \cdot 8^2$ | 38. $540^2 - 550^2$ | 39. $7 \cdot 68^2 - 2 \cdot 32^2$ | 40. $0 \cdot 003^2 - 0 \cdot 002^2$ |

2.9 Quadratic equations

So far, we have met linear equations which have one solution only. Quadratic equations always have an x^2 term, and often an x term and a number term, and generally have two different solutions.

Solution by factors

Consider the equation $a \times b = 0$, where a and b are numbers. The product $a \times b$ can only be zero if either a or b (or both) is equal to zero. Can you think of other possible pairs of numbers which multiply together to give zero?

Example 1

Solve the equation $x^2 + x - 12 = 0$

Factorising, $(x - 3)(x + 4) = 0$

either $x - 3 = 0$ or $x + 4 = 0$
 $x = 3$ $x = -4$

Example 2

Solve the equation $6x^2 + x - 2 = 0$

Factorising, $(2x - 1)(3x + 2) = 0$

either $2x - 1 = 0$ or $3x + 2 = 0$
 $2x = 1$ $3x = -2$
 $x = \frac{1}{2}$ $x = -\frac{2}{3}$

Exercise 26

Solve the following equations:

- | | | |
|-------------------------|--------------------------|--------------------------|
| 1. $x^2 + 7x + 12 = 0$ | 2. $x^2 + 7x + 10 = 0$ | 3. $x^2 + 2x - 15 = 0$ |
| 4. $x^2 + x - 6 = 0$ | 5. $x^2 - 8x + 12 = 0$ | 6. $x^2 + 10x + 21 = 0$ |
| 7. $x^2 - 5x + 6 = 0$ | 8. $x^2 - 4x - 5 = 0$ | 9. $x^2 + 5x - 14 = 0$ |
| 10. $2x^2 - 3x - 2 = 0$ | 11. $3x^2 + 10x - 8 = 0$ | 12. $2x^2 + 7x - 15 = 0$ |

13. $6x^2 - 13x + 6 = 0$

16. $y^2 - 15y + 56 = 0$

19. $x^2 + 2x + 1 = 0$

22. $x^2 - 14x + 49 = 0$

25. $z^2 - 8z - 65 = 0$

28. $y^2 - 2y + 1 = 0$

14. $4x^2 - 29x + 7 = 0$

17. $12y^2 - 16y + 5 = 0$

20. $x^2 - 6x + 9 = 0$

23. $6a^2 - a - 1 = 0$

26. $6x^2 + 17x - 3 = 0$

29. $36x^2 + x - 2 = 0$

15. $10x^2 - x - 3 = 0$

18. $y^2 + 2y - 63 = 0$

21. $x^2 + 10x + 25 = 0$

24. $4a^2 - 3a - 10 = 0$

27. $10k^2 + 19k - 2 = 0$

30. $20x^2 - 7x - 3 = 0$

Example 1Solve the equation $x^2 - 7x = 0$ Factorising, $x(x - 7) = 0$ either $x = 0$ or $x - 7 = 0$

$$x = 7$$

The solutions are $x = 0$ and $x = 7$.**Example 2**Solve the equation $4x^2 - 9 = 0$ (a) Factorising, $(2x - 3)(2x + 3) = 0$ either $2x - 3 = 0$ or $2x + 3 = 0$

$$2x = 3 \qquad 2x = -3$$

$$x = \frac{3}{2} \qquad x = -\frac{3}{2}$$

(b) Alternative method

$$4x^2 - 9 = 0$$

$$4x^2 = 9$$

$$x^2 = \frac{9}{4}$$

$$x = +\frac{3}{2} \text{ or } -\frac{3}{2}$$

Hint

You must give both the solutions. A common error is to only give the positive square root.

Exercise 27

Solve the following equations:

1. $x^2 - 3x = 0$

4. $3x^2 - x = 0$

7. $4x^2 - 1 = 0$

10. $6a^2 - 9a = 0$

13. $y^2 - \frac{1}{4} = 0$

16. $x^2 = 6x$

19. $x^2 = x$

22. $4x^2 = 1$

25. $12x = 5x^2$

28. $2x^2 = \frac{x}{3}$

2. $x^2 + 7x = 0$

5. $x^2 - 16 = 0$

8. $9x^2 - 4 = 0$

11. $10x^2 - 55x = 0$

14. $56x^2 - 35x = 0$

17. $x^2 = 11x$

20. $4x = x^2$

23. $9x^2 = 16$

26. $1 - 9x^2 = 0$

29. $4x^2 = \frac{1}{4}$

3. $2x^2 - 2x = 0$

6. $x^2 - 49 = 0$

9. $6y^2 + 9y = 0$

12. $16x^2 - 1 = 0$

15. $36x^2 - 3x = 0$

18. $2x^2 = 3x$

21. $3x - x^2 = 0$

24. $x^2 = 9$

27. $x^2 = \frac{x}{4}$

30. $\frac{x}{5} - x^2 = 0$

Solution by formula

The solutions of the quadratic equation $ax^2 + bx + c = 0$ are given by the formula

$$x = \frac{-b \pm \sqrt{b^2 - 4ac}}{2a}$$

Use this formula only after trying (and failing) to factorise.

Example

Solve the equation $2x^2 - 3x - 4 = 0$.

In this case $a = 2$, $b = -3$, $c = -4$.

$$x = \frac{-(-3) \pm \sqrt{(-3)^2 - (4 \times 2 \times -4)}}{2 \times 2}$$

$$x = \frac{3 \pm \sqrt{9 + 32}}{4} = \frac{3 \pm \sqrt{41}}{4} = \frac{3 \pm 6.403}{4}$$

$$\text{either } x = \frac{3 + 6.403}{4} = 2.35 \text{ (2 decimal places)} \quad \text{or} \quad x = \frac{3 - 6.403}{4} = -0.85 \text{ (2 decimal places).}$$

Exercise 28

Solve the following, giving answers to two decimal places where necessary:

- | | | |
|-----------------------------------|-------------------------------|----------------------------|
| 1. $2x^2 + 11x + 5 = 0$ | 2. $3x^2 + 11x + 6 = 0$ | 3. $6x^2 + 7x + 2 = 0$ |
| 4. $3x^2 - 10x + 3 = 0$ | 5. $5x^2 - 7x + 2 = 0$ | 6. $6x^2 - 11x + 3 = 0$ |
| 7. $2x^2 + 6x + 3 = 0$ | 8. $x^2 + 4x + 1 = 0$ | 9. $5x^2 - 5x + 1 = 0$ |
| 10. $x^2 - 7x + 2 = 0$ | 11. $2x^2 + 5x - 1 = 0$ | 12. $3x^2 + x - 3 = 0$ |
| 13. $3x^2 + 8x - 6 = 0$ | 14. $3x^2 - 7x - 20 = 0$ | 15. $2x^2 - 7x - 15 = 0$ |
| 16. $x^2 - 3x - 2 = 0$ | 17. $2x^2 + 6x - 1 = 0$ | 18. $6x^2 - 11x - 7 = 0$ |
| 19. $3x^2 + 25x + 8 = 0$ | 20. $3y^2 - 2y - 5 = 0$ | 21. $2y^2 - 5y + 1 = 0$ |
| 22. $\frac{1}{2}y^2 + 3y + 1 = 0$ | 23. $2 - x - 6x^2 = 0$ | 24. $3 + 4x - 2x^2 = 0$ |
| 25. $1 - 5x - 2x^2 = 0$ | 26. $3x^2 - 1 + 4x = 0$ | 27. $5x - x^2 + 2 = 0$ |
| 28. $24x^2 - 22x - 35 = 0$ | 29. $36x^2 - 17x - 35 = 0$ | 30. $20x^2 + 17x - 63 = 0$ |
| 31. $x^2 + 2.5x - 6 = 0$ | 32. $0.3y^2 + 0.4y - 1.5 = 0$ | 33. $10 - x - 3x^2 = 0$ |
| 34. $x^2 + 3.3x - 0.7 = 0$ | 35. $12 - 5x^2 - 11x = 0$ | 36. $5x - 2x^2 + 187 = 0$ |

The solution to a problem can involve an equation which does not at first appear to be quadratic. The terms in the equation may need to be rearranged as shown below.

Example

$$\begin{aligned} \text{Solve:} \quad & 2x(x-1) = (x+1)^2 - 5 \\ & 2x^2 - 2x = x^2 + 2x + 1 - 5 \\ 2x^2 - 2x - x^2 - 2x - 1 + 5 &= 0 \\ x^2 - 4x + 4 &= 0 \\ (x-2)(x-2) &= 0 \\ x &= 2 \end{aligned}$$

In this example the quadratic has a repeated solution of $x = 2$.

Exercise 29

Solve the following, giving answers to two decimal places where necessary:

1. $x^2 = 6 - x$

3. $3x + 2 = 2x^2$

5. $6x(x + 1) = 5 - x$

7. $(x - 3)^2 = 10$

9. $(2x - 1)^2 = (x - 1)^2 + 8$

11. $x = \frac{15}{x} - 22$

13. $4x + \frac{7}{x} = 29$

15. $2x^2 = 7x$

17. $2x + 2 = \frac{7}{x} - 1$

19. $\frac{3}{x-1} + \frac{3}{x+1} = 4$

21. One of the solutions published by Cardan in 1545 for the solution of cubic equations is given below. For an equation in the form $x^3 + px = q$

$$x = \sqrt[3]{\left[\sqrt{\left(\frac{p}{3}\right)^3 + \left(\frac{q}{2}\right)^2} + \frac{q}{2}\right]} - \sqrt[3]{\left[\sqrt{\left(\frac{p}{3}\right)^3 + \left(\frac{q}{2}\right)^2} - \frac{q}{2}\right]}$$

Use the formula to solve the following equations, giving answers to 4 sig. fig. where necessary.

(a) $x^3 + 7x = -8$

(b) $x^3 + 6x = 4$

(c) $x^3 + 3x = 2$

(d) $x^3 + 9x - 2 = 0$

2.10 Problems solved by quadratic equations**Example 1**

The perimeter of a rectangle is 42 cm. If the diagonal is 15 cm, find the width of the rectangle.

Let the width of the rectangle be x cm.

Since the perimeter is 42 cm, the sum of the length and the width is 21 cm.

\therefore length of rectangle = $(21 - x)$ cm

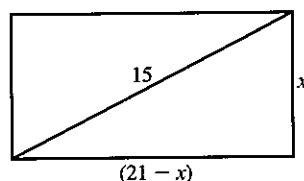

By Pythagoras' theorem

$$\begin{aligned}x^2 + (21 - x)^2 &= 15^2 \\x^2 + (21 - x)(21 - x) &= 15^2 \\x^2 + 441 - 42x + x^2 &= 225 \\2x^2 - 42x + 216 &= 0 \\x^2 - 21x + 108 &= 0 \\(x - 12)(x - 9) &= 0 \\x &= 12 \\ \text{or } x &= 9\end{aligned}$$

Note that the dimensions of the rectangle are 9 cm and 12 cm, whichever value of x is taken.

\therefore The width of the rectangle is 9 cm.

Example 2

A man bought a certain number of golf balls for \$20. If each ball had cost 20 cents less, he could have bought five more for the same money. How many golf balls did he buy?

Let the number of balls bought be x .

$$\text{Cost of each ball} = \frac{2000}{x} \text{ cents}$$

If five more balls had been bought

$$\text{Cost of each ball now} = \frac{2000}{(x + 5)} \text{ cents}$$

The new price is 20 cents less than the original price.

$$\therefore \frac{2000}{x} - \frac{2000}{(x + 5)} = 20$$

(multiply by x)

$$x \cdot \frac{2000}{x} - x \cdot \frac{2000}{(x + 5)} = 20x$$

(multiply by $(x + 5)$)

$$\begin{aligned}2000(x + 5) - x \frac{2000}{(x + 5)}(x + 5) &= 20x(x + 5) \\2000x + 10\,000 - 2000x &= 20x^2 + 100x \\20x^2 + 100x - 10\,000 &= 0 \\x^2 + 5x - 500 &= 0 \\(x - 20)(x + 25) &= 0 \\x &= 20 \\ \text{or } x &= -25\end{aligned}$$

We discard $x = -25$ as meaningless.

The number of balls bought = 20.

You can find out more about
Pythagoras' Theorem in Unit 4
on page 119.



Exercise 30

Solve by forming a quadratic equation:

- Two numbers, which differ by 3, have a product of 88. Find them.
- The product of two consecutive odd numbers is 143. Find the numbers. (Hint: If the first odd number is x , what is the next odd number?)
- The length of a rectangle exceeds the width by 7 cm. If the area is 60 cm^2 , find the length of the rectangle.
- The length of a rectangle exceeds the width by 2 cm. If the diagonal is 10 cm long, find the width of the rectangle.
- The area of the rectangle exceeds the area of the square by 24 m^2 . Find x .

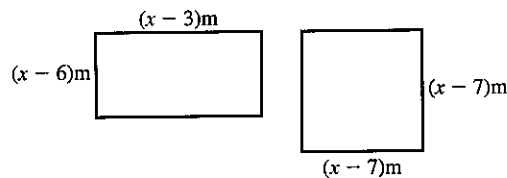

- The perimeter of a rectangle is 68 cm. If the diagonal is 26 cm, find the dimensions of the rectangle.
- A man walks a certain distance due North and then the same distance plus a further 7 km due East. If the final distance from the starting point is 17 km, find the distances he walks North and East.
- A farmer makes a profit of x cents on each of the $(x+5)$ eggs her hen lays. If her total profit was 84 cents, find the number of eggs the hen lays.
- A boy buys x eggs at $(x-8)$ cents each and $(x-2)$ rashers of bacon at $(x-3)$ cents each. If the total bill is \$1.75, how many eggs does he buy?
- A number exceeds four times its reciprocal by 3. Find the number.
- Two numbers differ by 3. The sum of their reciprocals is $\frac{7}{10}$; find the numbers.
- A cyclist travels 40 km at a speed of x km/h. Find the time taken in terms of x . Find the time taken when his speed is reduced by 2 km/h. If the difference between the times is 1 hour, find the original speed x .
- An increase of speed of 4 km/h on a journey of 32 km reduces the time taken by 4 hours. Find the original speed.
- A train normally travels 240 km at a certain speed. One day, due to bad weather, the train's speed is reduced by 20 km/h so that the journey takes two hours longer. Find the normal speed.

Questions 4, 6 and 7 use
Pythagoras' Theorem.

15. The speed of a sparrow is x km/h in still air. When the wind is blowing at 1 km/h, the sparrow takes 5 hours to fly 12 kilometres to her nest and 12 kilometres back again. She goes out directly into the wind and returns with the wind behind her. Find her speed in still air.
16. An aircraft flies a certain distance on a bearing of 135° and then twice the distance on a bearing of 225° . Its distance from the starting point is then 350 km. Find the length of the first part of the journey.
17. In Figure 1, ABCD is a rectangle with $AB = 12$ cm and $BC = 7$ cm. $AK = BL = CM = DN = x$ cm. If the area of KLMN is 54 cm² find x .

A bearing is a clockwise angle measured from North.

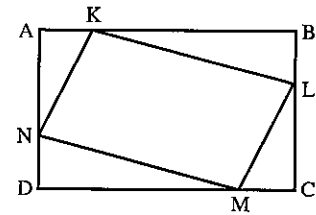

Figure 1

18. In Figure 1, $AB = 14$ cm, $BC = 11$ cm and $AK = BL = CM = DN = x$ cm. If the area of KLMN is now 97 cm², find x .
19. The numerator of a fraction is 1 less than the denominator. When both numerator and denominator are increased by 2, the fraction is increased by $\frac{1}{12}$. Find the original fraction.
20. The perimeters of a square and a rectangle are equal. One side of the rectangle is 11 cm and the area of the square is 4 cm² more than the area of the rectangle. Find the side of the square.

Revision exercise 2A

1. Solve the equations:
- | | |
|--------------------------|-------------------|
| (a) $x + 4 = 3x + 9$ | (b) $9 - 3a = 1$ |
| (c) $y^2 + 5y = 0$ | (d) $x^2 - 4 = 0$ |
| (e) $3x^2 + 7x - 40 = 0$ | |
2. Given $a = 3$, $b = 4$ and $c = -2$, evaluate:
- | | |
|------------------|----------------|
| (a) $2a^2 - b$ | (b) $a(b - c)$ |
| (c) $2b^2 - c^2$ | |
3. Factorise completely:
- | | |
|---------------------------|---------------------|
| (a) $4x^2 - y^2$ | (b) $2x^2 + 8x + 6$ |
| (c) $6m + 4n - 9km - 6kn$ | |
| (d) $2x^2 - 5x - 3$ | |
4. Solve the simultaneous equations:
- | | |
|--------------------|--------------------|
| (a) $3x + 2y = 5$ | (b) $2m - n = 6$ |
| $2x - y = 8$ | $2m + 3n = -6$ |
| (c) $3x - 4y = 19$ | (d) $3x - 7y = 11$ |
| $x + 6y = 10$ | $2x - 3y = 4$ |

Questions 13 and 20 use Pythagoras' Theorem.

5. Given that $x = 4$, $y = 3$, $z = -2$, evaluate:

- (a) $2x(y + z)$ (b) $(xy)^2 - z^2$
 (c) $x^2 + y^2 + z^2$ (d) $(x + y)(x - z)$
 (e) $\sqrt{x(1 - 4z)}$ (f) $\frac{xy}{z}$

6. (a) Simplify $3(2x - 5) - 2(2x + 3)$.

(b) Factorise $2a - 3b - 4xa + 6xb$.

(c) Solve the equation $\frac{x - 11}{2} - \frac{x - 3}{5} = 2$.

7. Solve the equations:

- (a) $5 - 7x = 4 - 6x$ (b) $\frac{7}{x} = \frac{2}{3}$
 (c) $2x^2 - 7x = 0$ (d) $x^2 + 5x + 6 = 0$
 (e) $\frac{1}{x} + \frac{1}{4} = \frac{1}{3}$

8. Factorise completely:

- (a) $z^3 - 16z$ (b) $x^2y^2 + x^2 + y^2 + 1$
 (c) $2x^2 + 11x + 12$

9. Find the value of $\frac{2x - 3y}{5x + 2y}$ when $x = 2a$ and $y = -a$.

10. Solve the simultaneous equations:

- (a) $7c + 3d = 29$ (b) $2x - 3y = 7$
 $5c - 4d = 33$ $2y - 3x = -8$
 (c) $5x = 3(1 - y)$ (d) $5s + 3t = 16$
 $3x + 2y + 1 = 0$ $11s + 7t = 34$

11. Solve the equations:

- (a) $4(y + 1) = \frac{3}{1 - y}$
 (b) $4(2x - 1) - 3(1 - x) = 0$
 (c) $\frac{x + 3}{x} = 2$
 (d) $x^2 = 5x$

12. Solve the following, giving your answers correct to two decimal places.

- (a) $2x^2 - 3x - 1 = 0$ (b) $x^2 - x - 1 = 0$
 (c) $3x^2 + 2x - 4 = 0$ (d) $x + 3 = \frac{7}{x}$

13. Find x by forming a suitable equation.

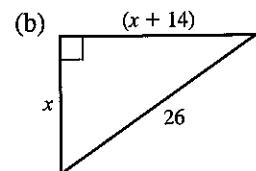
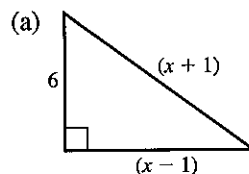

14. Given that $m = -2$, $n = 4$, evaluate:

(a) $5m + 3n$

(b) $5 + 2m - m^2$

(c) $m^2 + 2n^2$

(d) $(2m + n)(2m - n)$

(e) $(n - m)^2$

(f) $n - mn - 2m^2$

15. A car travels for x hours at a speed of $(x + 2)$ km/h. If the distance travelled is 15 km, write down an equation for x and solve it to find the speed of the car.

16. ABCD is a rectangle, where $AB = x$ cm and BC is 1.5 cm less than AB.

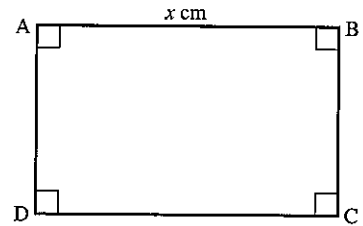

If the area of the rectangle is 52 cm^2 , form an equation in x and solve it to find the dimensions of the rectangle.

17. Solve the equations:

(a) $(2x + 1)^2 = (x + 5)^2$

(b) $\frac{x+2}{2} - \frac{x-1}{3} = \frac{x}{4}$

(c) $x^2 - 7x + 5 = 0$, giving the answers correct to two decimal places.

18. Solve the equation:

$$\frac{x}{x+1} - \frac{x+1}{3x-1} = \frac{1}{4}$$

19. Given that $a + b = 2$ and that $a^2 + b^2 = 6$, prove that $2ab = -2$. Find also the value of $(a - b)^2$.

20. The sides of a right-angled triangle have lengths $(x - 3)$ cm, $(x + 11)$ cm and $2x$ cm, where $2x$ is the hypotenuse. Find x .

21. A piggy-bank contains 50 coins, all either 2 cents or 5 cents. The total value of the coins is \$1.87. How many 2 cents coins are there?

22. Pat bought 45 stamps, some for 10c and some for 18c. If he spent \$6.66 altogether, how many 10c stamps did he buy?

23. When each edge of a cube is decreased by 1 cm, its volume is decreased by 91 cm^3 . Find the length of a side of the original cube.

24. One solution of the equation $2x^2 - 7x + k = 0$ is $x = -\frac{1}{2}$. Find the value of k .

Examination exercise 2B

1. The diagram shows a square picture in a square frame of side x cm.
The width of the border all round the picture is 2 cm, and the area of the border is 112 cm^2 .
- (a) Use this information to form an equation in x .
(b) Solve your equation to find the value of x . N 96 2

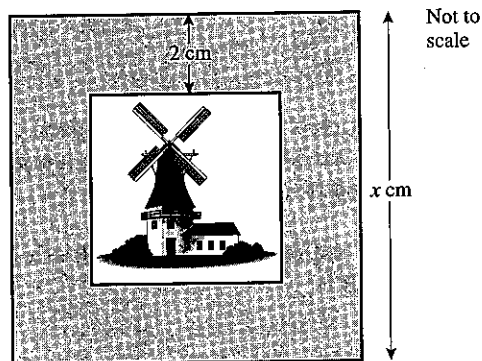

2. A bank uses the formula $A = P\left(1 + \frac{r}{100}\right)^n$ to calculate the amount of money in an account.
- (a) Calculate A when $P = 800$, $r = 6$ and $n = 5$, correct to two decimal places.
(b) When $n = 1$, the formula is

$$A = P\left(1 + \frac{r}{100}\right).$$

Make r the subject of this formula.

N 97 2

3. In a set of three numbers,
the first is a positive integer,
the second is three more than the first
and the third is the square of the second.
- (a) The first number in the set is x .
Write the second and third numbers in terms of x .
(b) The sum of the three numbers is 77.
(i) Write down an equation in x .
(ii) Show that your equation simplifies to $x^2 + 8x - 65 = 0$.
(iii) Solve the equation $x^2 + 8x - 65 = 0$.
(iv) Write down the three numbers. N 96 4

4. Give exact answers to each part of this question.
It is given that

$$1^2 + 2^2 + 3^2 + \dots + k^2 = \frac{k(k+1)(2k+1)}{6}.$$

- (a) Substitute $k = 100$ in the formula above to find the value of $1^2 + 2^2 + 3^2 + \dots + 100^2$.
(b) $2^2 + 4^2 + 6^2 + \dots + 100^2 = 2^2(1^2 + 2^2 + 3^2 + \dots + n^2)$.
(i) Write down the value of n .
(ii) Hence find the value of $2^2 + 4^2 + 6^2 + \dots + 100^2$.
(c) Use your answers to parts (a) and (b) (ii) to find the value of $1^2 + 3^2 + 5^2 + \dots + 99^2$.
(d) Use some of your previous answers to find the value of:
 $1^2 - 2^2 + 3^2 - 4^2 + 5^2 - 6^2 + \dots + 99^2 - 100^2$ J 95 4

5. (a) Write as a single fraction:

$$\frac{2x+1}{3} - \frac{x-1}{2}$$

- (b) (i) Factorise:
- $x^2 - 5x + 6$
-
- (ii) Simplify:

$$\frac{x^2 - 5x + 6}{x^2 + x - 6}$$

- (c) Solve the equation:

$$3x^2 = 7x - 1$$

Show all your working and give your answers correct to two decimal places. N 96 4

6. (a) (i) Write down the next two terms in the sequence:

$$\frac{1}{2}, \frac{2}{3}, \frac{3}{5}, \frac{5}{8}, \frac{8}{13}, \text{---}, \text{---}$$

- (ii) This can be written in the form:

$$\frac{a}{b}, \frac{b}{a+b}, \frac{a+b}{a+2b}, \text{---}, \text{---}$$

Write down the next two terms of the sequence in terms of a and b .

- (b) A different sequence follows the pattern:

$$\frac{1}{x}, \frac{2}{x+1}, \frac{3}{x+2}, \frac{4}{x+3}, \text{---}, \text{---}$$

- (i) Write down the next two terms of this sequence.
-
- (ii) Write down the 100th term of this sequence.

- (iii) Find
- x
- if the
- tenth*
- term equals
- $\frac{1}{2}$
- .

J 96 4

7. Three positive integers are
- $(x-1)$
- ,
- x
- and
- $(x+1)$
- .

When they are multiplied together the answer is 40 times their sum.

- (a) (i) Write down an equation in
- x
- .
-
- (ii) Show that your equation simplifies to
- $x^3 - 121x = 0$
- .
-
- (b) Factorise
- completely**
- ,
- $x^3 - 121x$
- .
-
- (c) Find the three positive integers.

J 98 2

8. (a) Write the expression
- $\frac{100}{x-2} - \frac{100}{x}$
- as a

single fraction and simplify your answer.

- (b) Rice costs
- x
- francs for one kilogram. How many kilograms can I buy for 100 francs?
-
- (c) When rice costs
- $(x-2)$
- francs for one kilogram, I can buy five more kilograms for 100 francs. Write down an equation in
- x
- . Show that it simplifies to
- $x^2 - 2x - 40 = 0$
- .
-
- (d) (i) Solve the equation
- $x^2 - 2x - 40 = 0$
- , giving your answers correct to two decimal places. Show all your working.
-
- (ii) Write down the original price of one kilogram of rice.

J 98 4

4 GEOMETRY



Pythagoras (569–500 B.C.) was one of the first of the great mathematical names in Greek antiquity. He settled in southern Italy and formed a mysterious brotherhood with his students who were bound by an oath not to reveal the secrets of numbers and who exercised great influence. They laid the foundations of arithmetic through geometry but failed to resolve the concept of irrational numbers. The work of these and others was brought together by Euclid at Alexandria in a book called 'The Elements' which was still studied in English schools as recently as 1900.

- 26** Use and interpret geometrical terms, including similarity and congruence; use the relationships between areas and volumes of similar figures; use and interpret vocabulary of shapes and simple solid figures including nets
- 27** Measure lines and angles; construct a triangle given three sides; construct angle bisectors and perpendicular bisectors
- 28** Recognise rotational and line symmetry
- 29** Calculate unknown angles using geometrical properties, including irregular polygons and circle theorems
- 30** Use loci in two dimensions
- 32** Apply Pythagoras' theorem

4.1 Fundamental results

You should already be familiar with the following results. They are used later in this section and are quoted here for reference.

- The angles on a straight line add up to 180° :

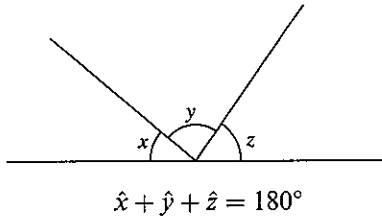

- The angles at a point add up to 360° :

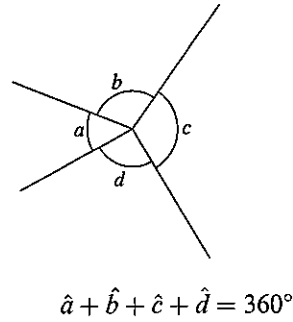

- The angle sum of a triangle is 180° .
- An isosceles triangle has 2 sides and 2 angles the same:

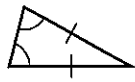

- The angle sum of a quadrilateral is 360° .
- An equilateral triangle has 3 sides and 3 angles the same:

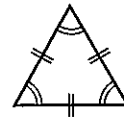

Exercise 1

Find the angles marked with letters. (AB is always a straight line.)

1. 2. 3. 4.

5. 6. 7. 8.

9. 10. 11. 12.

13.

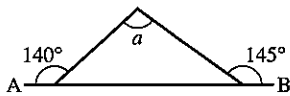

14.

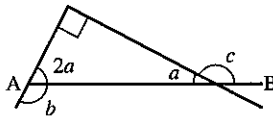

15.

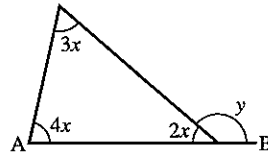

16.

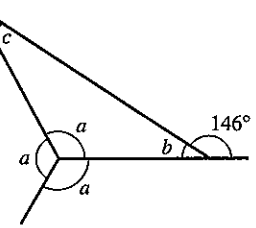

17.

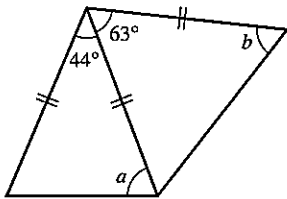

18.

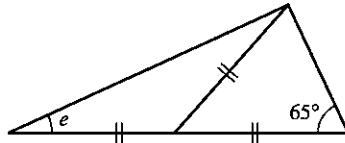

19.

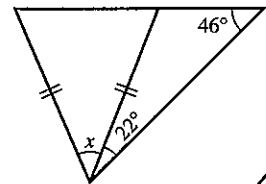

20.

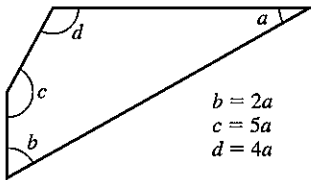

21.

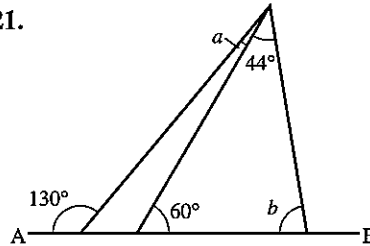

22.

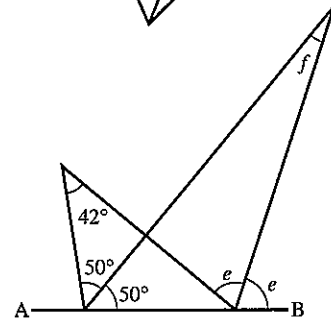

23. Calculate the largest angle of a triangle in which one angle is eight times each of the others.
24. In $\triangle ABC$, \hat{A} is a right angle and D is a point on AC such that BD bisects \hat{B} . If $\hat{BDC} = 100^\circ$, calculate \hat{C} .
25. $WXYZ$ is a quadrilateral in which $\hat{W} = 108^\circ$, $\hat{X} = 88^\circ$, $\hat{Y} = 57^\circ$ and $\hat{WXZ} = 31^\circ$. Calculate \hat{WZX} and \hat{XZY} .
26. In quadrilateral $ABCD$, AB produced is perpendicular to DC produced. If $\hat{A} = 44^\circ$ and $\hat{C} = 148^\circ$, calculate \hat{D} and \hat{B} .
27. Triangles ABD , CBD and ADC are all isosceles. Find the angle x .

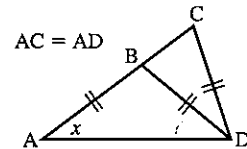

Polygons

- (i) The exterior angles of a polygon add up to 360° ($\hat{a} + \hat{b} + \hat{c} + \hat{d} + \hat{e} = 360^\circ$).
- (ii) The sum of the interior angles of a polygon is $(n - 2) \times 180^\circ$ where n is the number of sides of the polygon. This result is investigated in question 3 in the next exercise.
- (iii) A regular polygon has equal sides and equal angles.

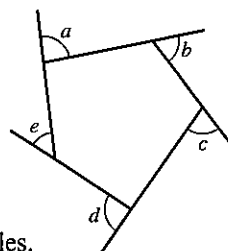

Remember
 pentagon = 5 sides
 hexagon = 6 sides
 octagon = 8 sides
 decagon = 10 sides

Example

Find the angles marked with letters.

The sum of the interior angles = $(n - 2) \times 180^\circ$
 where n is the number of sides of the polygon.

In this case $n = 6$.

$$\begin{aligned} \therefore 110 + 120 + 94 + 114 + 2t &= 4 \times 180 \\ 438 + 2t &= 720 \\ 2t &= 282 \\ t &= 141^\circ \end{aligned}$$

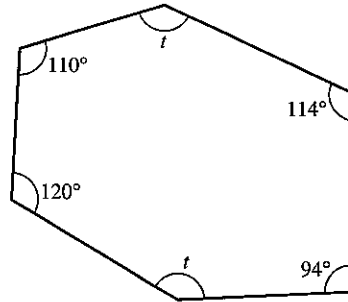

Exercise 2

1. Find angles a and b for the regular pentagon.

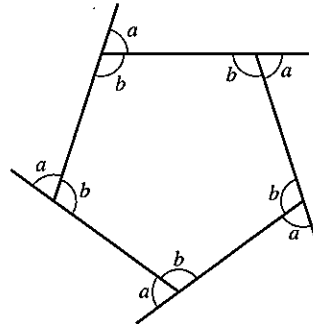

2. Find x and y .

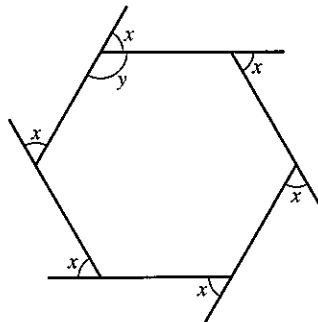

3. Consider the pentagon below which has been divided into three triangles.

$$\widehat{A} = a + f + g, \widehat{B} = b, \widehat{C} = c + d, \widehat{D} = e + i, \widehat{E} = h$$

$$\text{Now } a + b + c = d + e + f = g + h + i = 180^\circ$$

$$\begin{aligned} \therefore \widehat{A} + \widehat{B} + \widehat{C} + \widehat{D} + \widehat{E} &= a + b + c + d + e \\ &\quad + f + g + h + i \\ &= 3 \times 180^\circ \\ &= 6 \times 90^\circ \end{aligned}$$

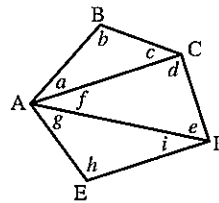

Draw further polygons and make a table of results.

Number of sides n	5	6	7	8...
Sum of interior angles	$3 \times 180^\circ$			

What is the sum of the interior angles for a polygon with n sides?

4. Find a .

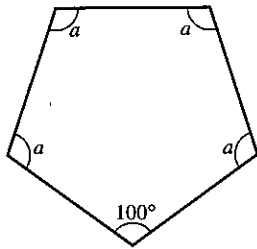

5. Find m .

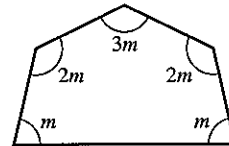

6. Find a .

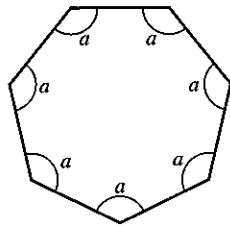

7. Calculate the number of sides of a regular polygon whose interior angles are each 156° .
8. Calculate the number of sides of a regular polygon whose interior angles are each 150° .
9. Calculate the number of sides of a regular polygon whose exterior angles are each 40° .
10. In a regular polygon each interior angle is 140° greater than each exterior angle. Calculate the number of sides of the polygon.
11. In a regular polygon each interior angle is 120° greater than each exterior angle. Calculate the number of sides of the polygon.
12. Two sides of a regular pentagon are produced to form angle x . What is x ?

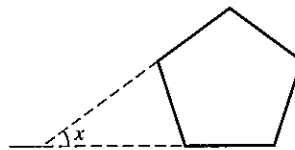

Parallel lines

- (i) $\hat{a} = \hat{c}$ (corresponding angles)
- (ii) $\hat{c} = \hat{d}$ (alternate angles)
- (iii) $\hat{b} + \hat{c} = 180^\circ$ (allied angles)

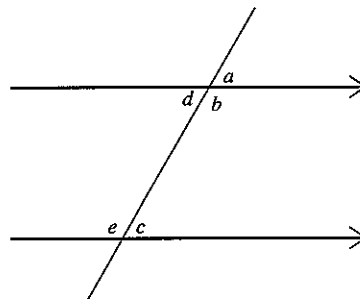

Remember: 'The acute angles (angles less than 90°) are the same and the obtuse angles (angles between 90° and 180°) are the same.'

Exercise 3

In questions 1 to 9 find the angles marked with letters.

1.

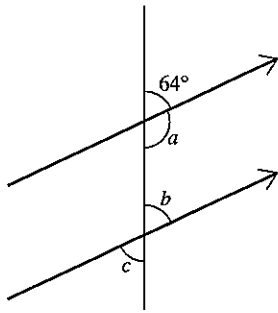

2.

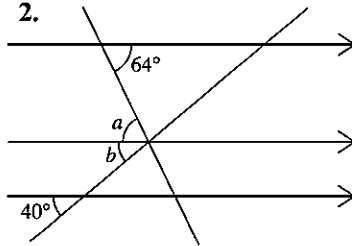

3.

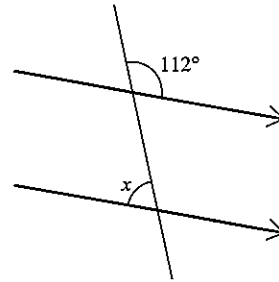

4.

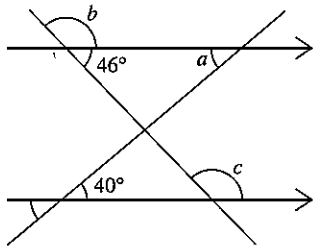

5.

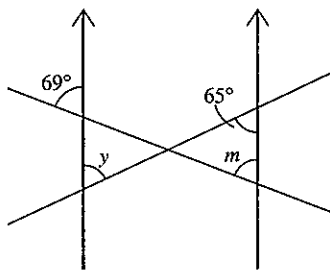

6.

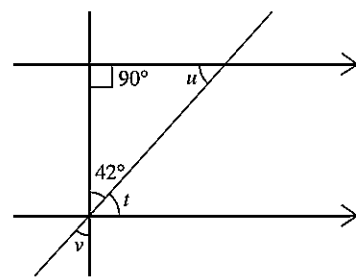

7.

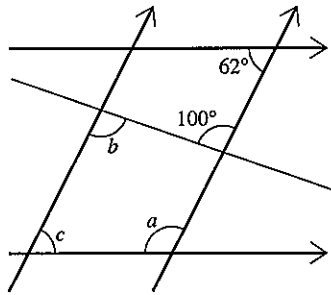

8.

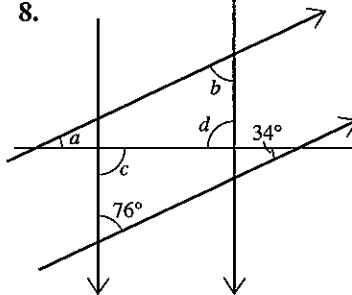

9.

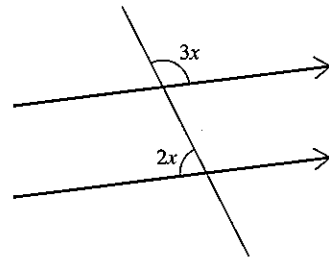

4.2 Pythagoras' theorem

In a right-angled triangle the square on the hypotenuse is equal to the sum of the squares on the other two sides.

$$a^2 + b^2 = c^2$$

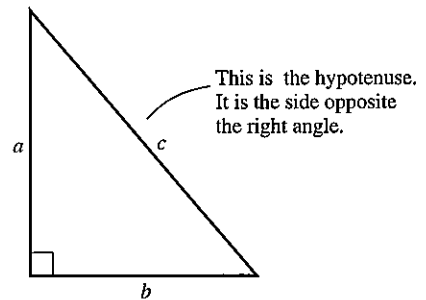

Example

Find the side marked d .

$$d^2 + 4^2 = 7^2$$

$$d^2 = 49 - 16$$

$$d = \sqrt{33} = 5.74 \text{ cm (3 sig. fig.)}$$

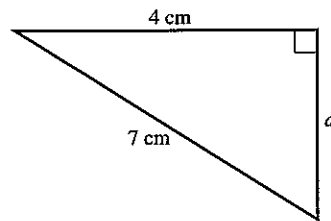

The *converse* is also true:

'If the square on one side of a triangle is equal to the sum of the squares on the other two sides, then the triangle is right-angled.'

Exercise 4

In questions 1 to 10, find x . All the lengths are in cm.

1.

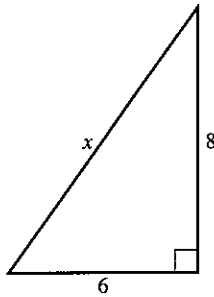

2.

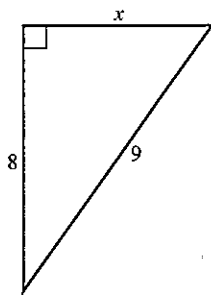

3.

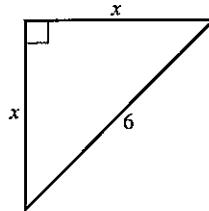

4.

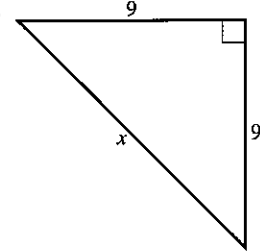

5.

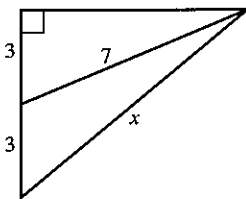

6.

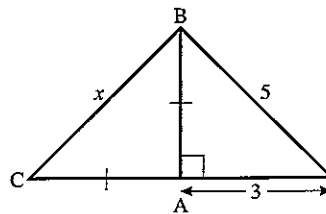

7.

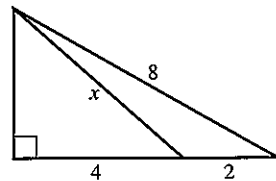

8.

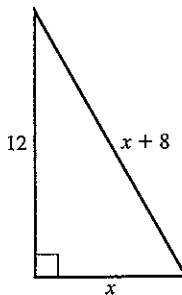

9.

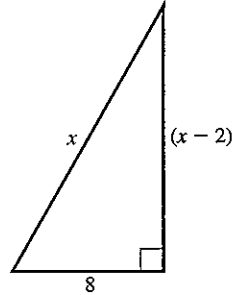

10.

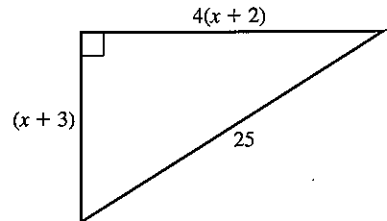

11. Find the length of a diagonal of a rectangle of length 9 cm and width 4 cm.

12. A square has diagonals of length 10 cm. Find the sides of the square.

13. A 4 m ladder rests against a vertical wall with its foot 2 m from the wall. How far up the wall does the ladder reach?

14. A ship sails 20 km due North and then 35 km due East. How far is it from its starting point?

15. Find the length of a diagonal of a rectangular box of length 12 cm, width 5 cm and height 4 cm.

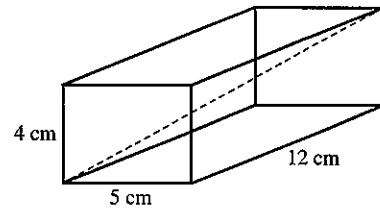

16. Find the length of a diagonal of a rectangular room of length 5 m, width 3 m and height 2.5 m.

17. Find the height of a rectangular box of length 8 cm, width 6 cm where the length of a diagonal is 11 cm.

18. An aircraft flies equal distances South-East and then South-West to finish 120 km due South of its starting-point. How long is each part of its journey?

19. The diagonal of a rectangle exceeds the length by 2 cm. If the width of the rectangle is 10 cm, find the length.

20. A cone has base radius 5 cm and *slant* height 11 cm. Find its vertical height.

21. It is possible to find the sides of a right-angled triangle, with lengths which are whole numbers, by substituting different values of x into the expressions:

(a) $2x^2 + 2x + 1$ (b) $2x^2 + 2x$ (c) $2x + 1$

((a) represents the hypotenuse, (b) and (c) the other two sides.)

(i) Find the sides of the triangles when $x = 1, 2, 3, 4$ and 5 .

(ii) Confirm that $(2x + 1)^2 + (2x^2 + 2x)^2 = (2x^2 + 2x + 1)^2$

22. The diagram represents the starting position (AB) and the finishing position (CD) of a ladder as it slips. The ladder is leaning against a vertical wall.

Given: $AC = x$, $OC = 4AC$, $BD = 2AC$ and $OB = 5$ m.

Form an equation in x , find x and hence find the length of the ladder.

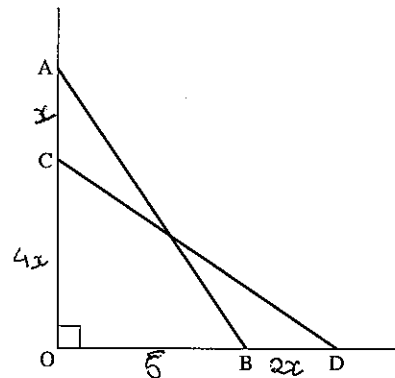

23. A thin wire of length 18 cm is bent into the shape shown. Calculate the length from A to B.

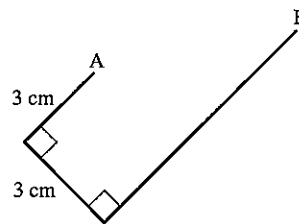

24. An aircraft is vertically above a point which is 10 km West and 15 km North of a control tower. If the aircraft is 4000 m above the ground, how far is it from the control tower?

4.3 Symmetry

Line symmetry

The letter A has one line of symmetry, shown dotted.

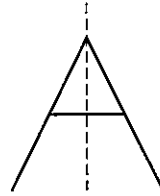

Rotational symmetry

The shape may be turned about O into three identical positions. It has rotational symmetry of order 3.

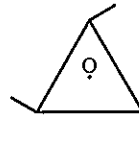

Quadrilaterals

1. *Square*

all sides are equal, all angles 90° , opposite sides parallel; diagonals bisect at right angles.

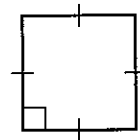

2. *Rectangle*

opposite sides parallel and equal, all angles 90° , diagonals bisect each other.

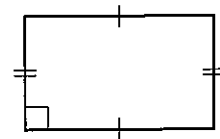

3. *Parallelogram*

opposite sides parallel and equal, opposite angles equal, diagonals bisect each other (but not equal).

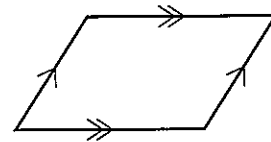

4. *Rhombus*

a parallelogram with all sides equal, diagonals bisect each other at right angles and bisect angles.

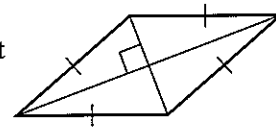

5. *Trapezium*

one pair of sides is parallel.

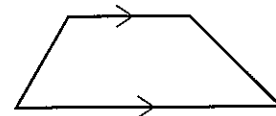

6. *Kite*

two pairs of adjacent sides equal, diagonals meet at right angles bisecting one of them.

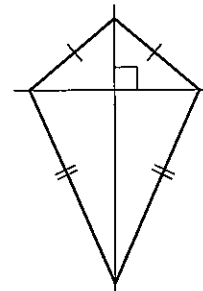

Exercise 5

1. For each shape state:

(a) the number of lines of symmetry (b) the order of rotational symmetry.

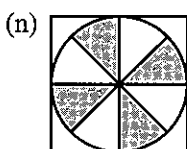
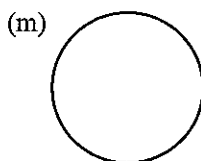
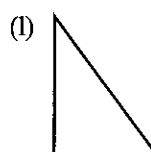
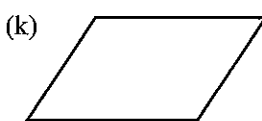
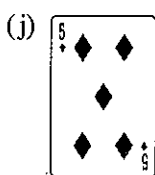
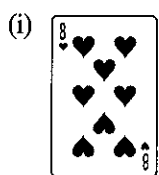
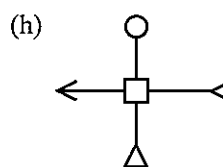
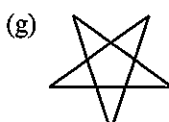
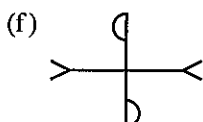
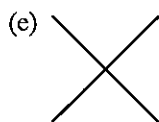
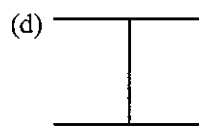
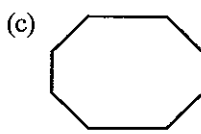
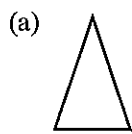

2. Add one line to each of the diagrams below so that the resulting figure has rotational symmetry but not line symmetry.

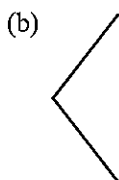
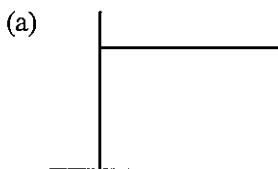

3. Draw a hexagon with just two lines of symmetry.

4. For each of the following shapes, find:

- (a) the number of lines of symmetry
(b) the order of rotational symmetry.

square; rectangle; parallelogram; rhombus; trapezium; kite;
equilateral triangle; regular hexagon.

In questions 5 to 15, begin by drawing a diagram.

5. In a rectangle $KLMN$, $\widehat{LNM} = 34^\circ$. Calculate:

- (a) \widehat{KLN} (b) \widehat{KML}

6. In a trapezium $ABCD$; $\widehat{ABD} = 35^\circ$, $\widehat{BAD} = 110^\circ$ and AB is parallel to DC . Calculate:

- (a) \widehat{ADB} (b) \widehat{BDC}

7. In a parallelogram WXYZ, $\widehat{WXY} = 72^\circ$, $\widehat{ZWY} = 80^\circ$. Calculate:
 (a) \widehat{WZY} (b) \widehat{XWZ} (c) \widehat{WYZ}
8. In a kite ABCD, $AB = AD$; $BC = CD$; $\widehat{CAD} = 40^\circ$ and $\widehat{CBD} = 60^\circ$. Calculate:
 (a) \widehat{BAC} (b) \widehat{BCA} (c) \widehat{ADC}
9. In a rhombus ABCD, $\widehat{ABC} = 64^\circ$. Calculate:
 (a) \widehat{BCD} (b) \widehat{ADB} (c) \widehat{BAC}
10. In a rectangle WXYZ, M is the mid-point of WX and $\widehat{ZMY} = 70^\circ$. Calculate:
 (a) \widehat{MZY} (b) \widehat{YMX}
11. In a trapezium ABCD, AB is parallel to DC, $AB = AD$, $BD = DC$ and $\widehat{BAD} = 128^\circ$. Find:
 (a) \widehat{ABD} (b) \widehat{BDC} (c) \widehat{BCD}
12. In a parallelogram KLMN, $KL = KM$ and $\widehat{KML} = 64^\circ$. Find:
 (a) \widehat{MKL} (b) \widehat{KNM} (c) \widehat{LMN}
13. In a kite PQRS with $PQ = PS$ and $RQ = RS$, $\widehat{QRS} = 40^\circ$ and $\widehat{QPS} = 100^\circ$. Find:
 (a) \widehat{QSR} (b) \widehat{PSQ} (c) \widehat{PQR}
14. In a rhombus PQRS, $\widehat{RPQ} = 54^\circ$. Find:
 (a) \widehat{PRQ} (b) \widehat{PSR} (c) \widehat{RQS}
15. In a kite PQRS, $\widehat{RPS} = 2\widehat{PRS}$, $PQ = QS = PS$ and $QR = RS$. Find:
 (a) \widehat{QPS} (b) \widehat{PRS} (c) \widehat{QSR} (d) \widehat{PQR}

4.4 Similarity

Two triangles are similar if they have the same angles. For other shapes, not only must corresponding angles be equal, but also corresponding sides must be in the same proportion.

The two rectangles A and B are *not* similar even though they have the same angles.

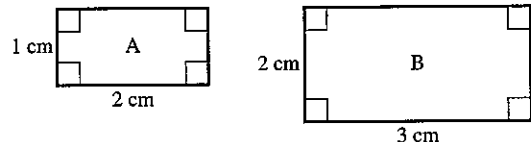

Example

In the triangles ABC and XYZ

$$\widehat{A} = \widehat{X} \text{ and } \widehat{B} = \widehat{Y}$$

so the triangles are similar. (\widehat{C} must be equal to \widehat{Z} .)

We have
$$\frac{BC}{YZ} = \frac{AC}{XZ} = \frac{AB}{XY}$$

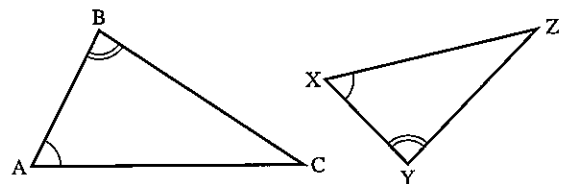

Exercise 6

Find the sides marked with letters in questions 1 to 11; all lengths are given in centimetres.

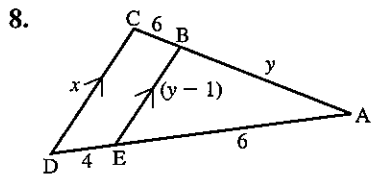
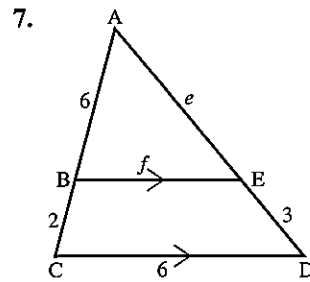
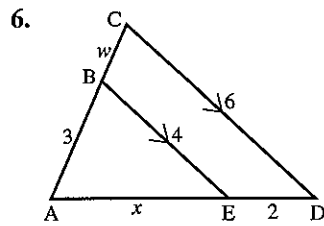
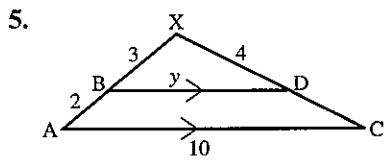
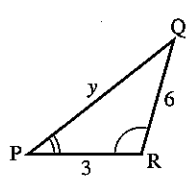
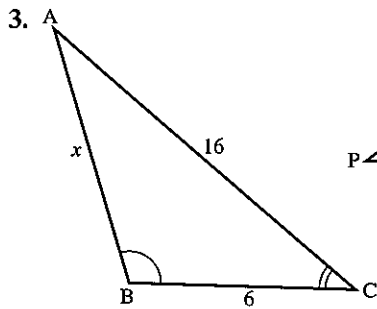
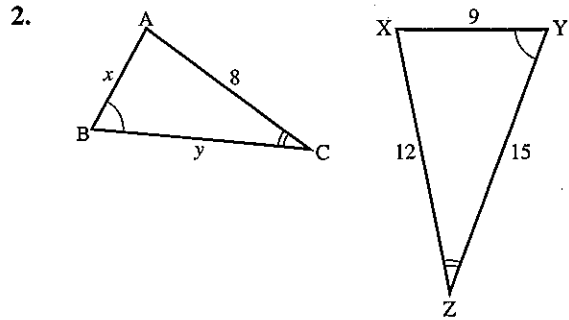
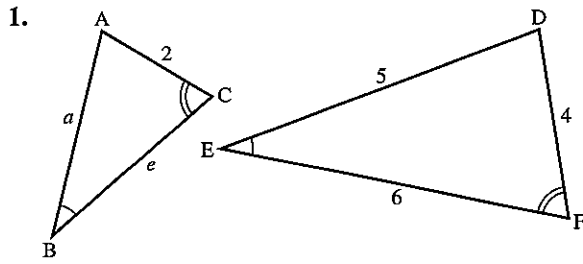

9. $\widehat{BAC} = \widehat{DBC}$

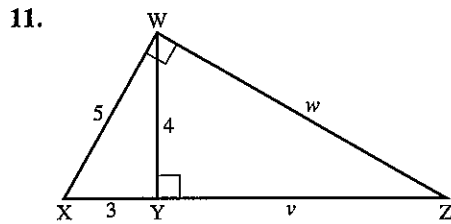
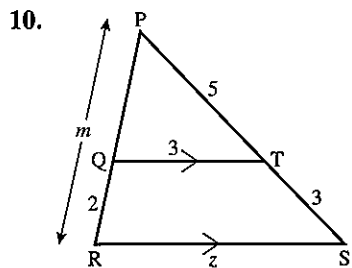
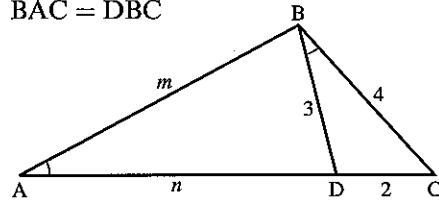

12. The drawing shows a rectangular picture $16\text{ cm} \times 8\text{ cm}$ surrounded by a border of width 4 cm . Are the two rectangles similar?

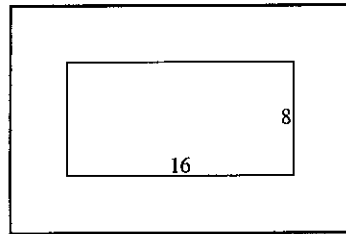

13. The diagonals of a trapezium $ABCD$ intersect at O . AB is parallel to DC , $AB = 3\text{ cm}$ and $DC = 6\text{ cm}$. If $CO = 4\text{ cm}$ and $OB = 3\text{ cm}$, find AO and DO .
14. A tree of height 4 m casts a shadow of length 6.5 m . Find the height of a house casting a shadow 26 m long.
15. Which of the following *must* be similar to each other?
- two equilateral triangles
 - two rectangles
 - two isosceles triangles
 - two squares
 - two regular pentagons
 - two kites
 - two rhombuses
 - two circles

16. In the diagram $\widehat{ABC} = \widehat{ADB} = 90^\circ$, $AD = p$ and $DC = q$.
- Use similar triangles to show that $x^2 = pz$.
 - Find a similar expression for y^2 .
 - Add the expressions for x^2 and y^2 and hence prove Pythagoras' theorem.

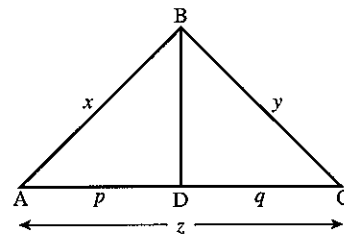

17. In a triangle ABC , a line is drawn parallel to BC to meet AB at D and AC at E . DC and BE meet at X . Prove that:
- the triangles ADE and ABC are similar
 - the triangles DXE and BXC are similar
 - $\frac{AD}{AB} = \frac{EX}{XB}$

18. From the rectangle $ABCD$ a square is cut off to leave rectangle $BCEF$. Rectangle $BCEF$ is similar to $ABCD$. Find x and hence state the ratio of the sides of rectangle $ABCD$. $ABCD$ is called the Golden Rectangle and is an important shape in architecture.

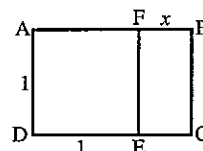

Congruence

Two plane figures are congruent if one fits exactly on the other. They must be the same size and the same shape.

Exercise 7

1. Identify pairs of congruent shapes below.

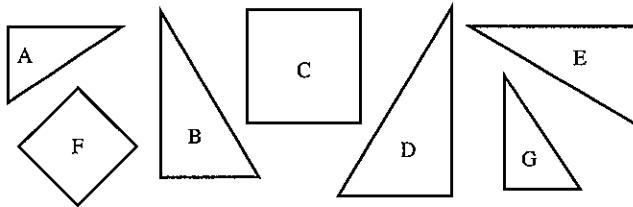

2. Triangle LMN is isosceles with $LM = LN$; X and Y are points on LM, LN respectively such that $LX = LY$. Prove that triangles LMY and LNX are congruent.
3. ABCD is a quadrilateral and a line through A parallel to BC meets DC at X. If $\widehat{D} = \widehat{C}$, prove that $\triangle ADX$ is isosceles.
4. In the diagram, N lies on a side of the square ABCD, AM and LC are perpendicular to DN. Prove that:
 (a) $\widehat{ADN} = \widehat{LCD}$ (b) $AM = LD$

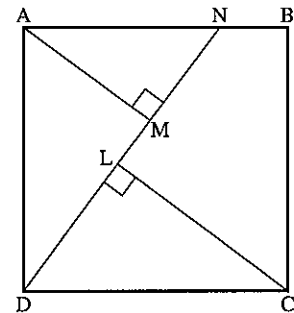

5. Points L and M on the side YZ of a triangle XYZ are drawn so that L is between Y and M. Given that $XY = XZ$ and $\widehat{YXL} = \widehat{MXZ}$, prove that $YL = MZ$.
6. Squares AMNB and AOPC are drawn on the sides of triangle ABC, so that they lie outside the triangle. Prove that $MC = OB$.
7. In the diagram, $\widehat{LMN} = \widehat{ONM} = 90^\circ$. P is the mid-point of MN, $MN = 2ML$ and $MN = NO$. Prove that:
 (a) the triangles MNL and NOP are congruent
 (b) $\widehat{OPN} = \widehat{LNO}$
 (c) $\widehat{LQO} = 90^\circ$

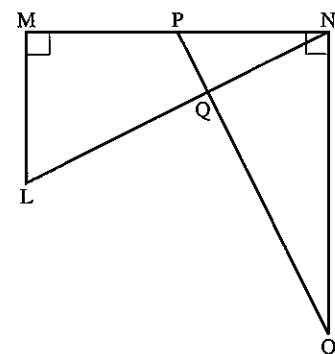

8. PQRS is a parallelogram in which the bisectors of the angles P and Q meet at X. Prove that the angle PXQ is a right angle.

Areas of similar shapes

The two rectangles are similar, the ratio of corresponding sides being k .

$$\begin{aligned} \text{area of } ABCD &= ab \\ \text{area of } WXYZ &= ka \times kb = k^2 ab \end{aligned}$$

$$\therefore \frac{\text{area } WXYZ}{\text{area } ABCD} = \frac{k^2 ab}{ab} = k^2$$

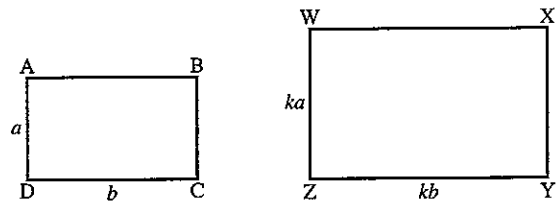

This illustrates an important general rule for all similar shapes:

If two figures are similar and the ratio of corresponding sides is k , then the ratio of their areas is k^2 .

Note: k is sometimes called the *linear scale factor*.

This result also applies for the surface areas of similar three-dimensional objects.

Example 1

XY is parallel to BC .

$$\frac{AB}{AX} = \frac{3}{2}$$

If the area of $\triangle AXY = 4 \text{ cm}^2$, find the area of $\triangle ABC$.

The triangles ABC and AXY are similar.

$$\text{Ratio of corresponding sides } (k) = \frac{3}{2}$$

$$\therefore \text{Ratio of areas } (k^2) = \frac{9}{4}$$

$$\begin{aligned} \therefore \text{Area of } \triangle ABC &= \frac{9}{4} \times (\text{area of } \triangle AXY) \\ &= \frac{9}{4} \times (4) = 9 \text{ cm}^2 \end{aligned}$$

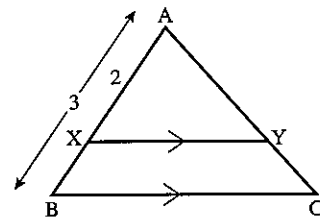

Example 2

Two similar triangles have areas of 18 cm^2 and 32 cm^2 respectively. If the base of the smaller triangle is 6 cm , find the base of the larger triangle.

$$\text{Ratio of areas } (k^2) = \frac{32}{18} = \frac{16}{9}$$

$$\begin{aligned} \therefore \text{Ratio of corresponding sides } (k) &= \sqrt{\left(\frac{16}{9}\right)} \\ &= \frac{4}{3} \end{aligned}$$

$$\therefore \text{Base of larger triangle} = 6 \times \frac{4}{3} = 8 \text{ cm}$$

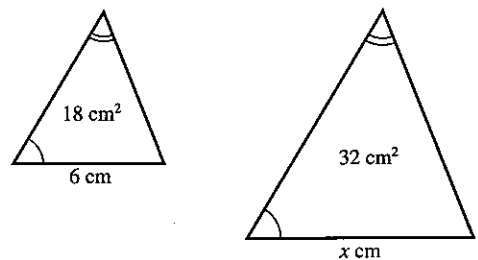

Exercise 8

In this exercise a number written inside a figure represents the area of the shape in cm^2 . Numbers on the outside give linear dimensions in cm. In questions 1 to 6 find the unknown area A . In each case the shapes are similar.

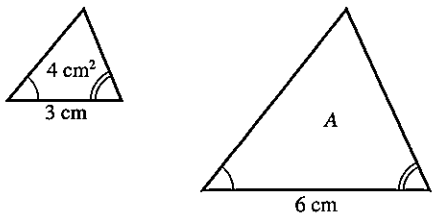
1. 

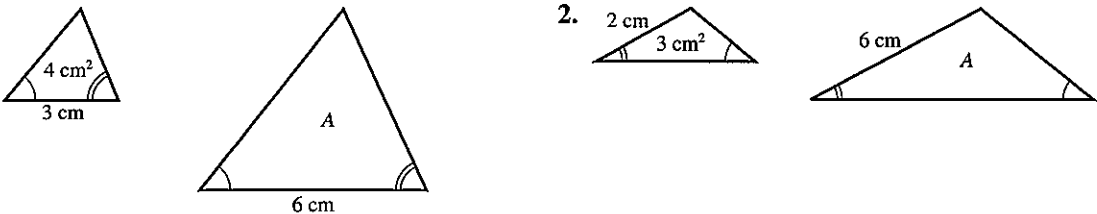
2. 

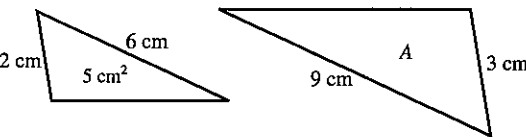
3. 

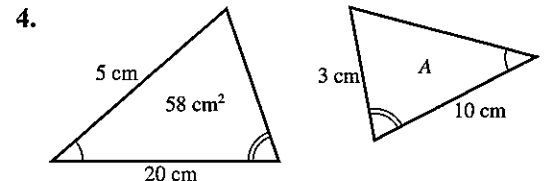
4. 

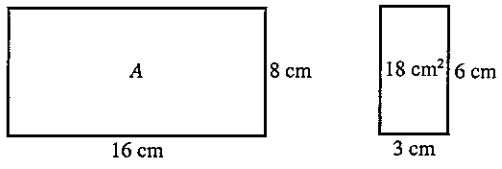
5. 

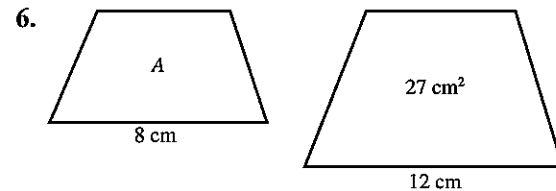
6. 

In questions 7 to 12, find the lengths marked for each pair of similar shapes.

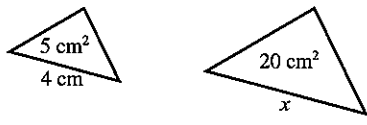
7. 

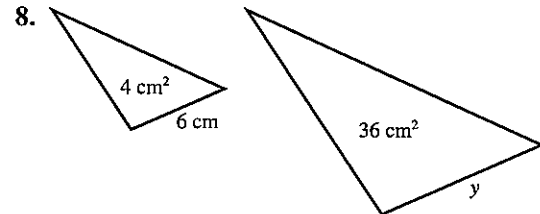
8. 

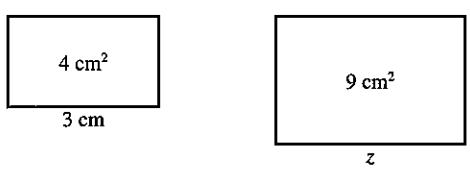
9. 

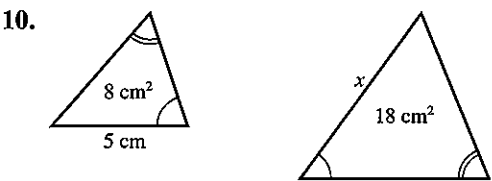
10. 

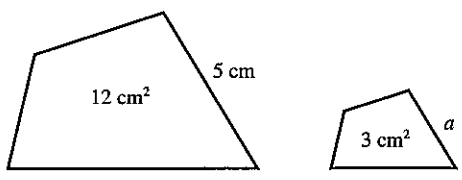
11. 

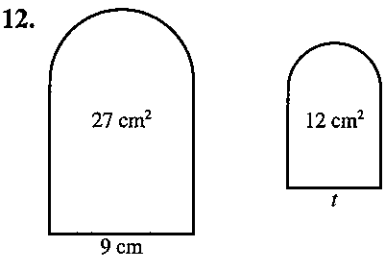
12. 

13. Given: $AD = 3$ cm, $AB = 5$ cm and area of $\triangle ADE = 6$ cm².
 Find:
 (a) area of $\triangle ABC$ (b) area of $DECB$

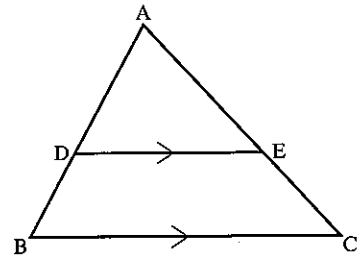

14. Given: $XY = 5$ cm, $MY = 2$ cm and area of $\triangle MYN = 4$ cm².
 Find:
 (a) area of $\triangle XYZ$ (b) area of $MNZX$

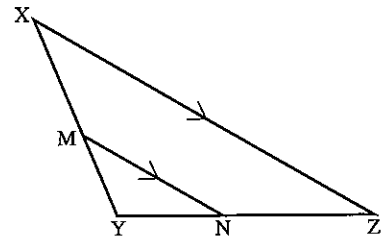

15. Given $XY = 2$ cm, $BC = 3$ cm and area of $XYCB = 10$ cm², find the area of $\triangle AXY$.

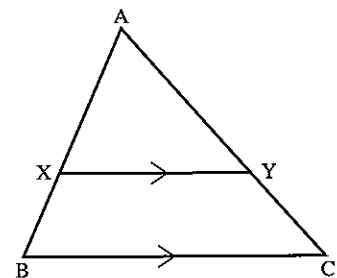

16. Given $KP = 3$ cm, area of $\triangle KOP = 2$ cm² and area of $OPML = 16$ cm², find the length of PM .

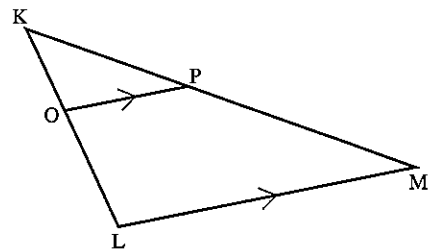

17. The triangles ABC and EBD are similar (AC and DE are *not* parallel).
 If $AB = 8$ cm, $BE = 4$ cm and the area of $\triangle DBE = 6$ cm², find the area of $\triangle ABC$.

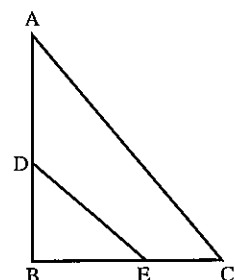

18. Given: $AZ = 3$ cm, $ZC = 2$ cm, $MC = 5$ cm, $BM = 3$ cm. Find:
 (a) XY
 (b) YZ
 (c) the ratio of areas $AXY : AYZ$
 (d) the ratio of areas $AXY : ABM$

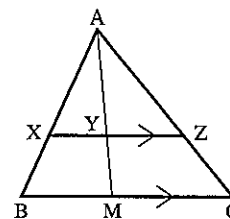

19. A floor is covered by 600 tiles which are 10 cm by 10 cm. How many 20 cm by 20 cm tiles are needed to cover the same floor?
20. A wall is covered by 160 tiles which are 15 cm by 15 cm. How many 10 cm by 10 cm tiles are needed to cover the same wall?
21. When potatoes are peeled do you lose more peel or less when big potatoes are used as opposed to small ones?

Volumes of similar objects

When solid objects are similar, one is an accurate enlargement of the other.

If two objects are similar and the ratio of corresponding sides is k , then the ratio of their volumes is k^3 .

A line has one dimension, and the scale factor is used once.

An area has two dimensions, and the scale factor is used twice.

A volume has three dimensions, and the scale factor is used three times.

Example 1

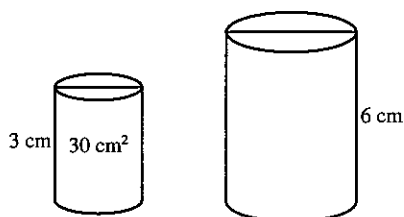

Two similar cylinders have heights of 3 cm and 6 cm respectively. If the volume of the smaller cylinder is 30 cm^3 , find the volume of the larger cylinder.

If linear scale factor = k , then ratio of heights (k) = $\frac{6}{3} = 2$

$$\therefore \text{ratio of volumes } (k^3) = 2^3 = 8$$

$$\text{and volume of larger cylinder} = 8 \times 30 = 240 \text{ cm}^3$$

Example 2

Two similar spheres made of the same material have weights of 32 kg and 108 kg respectively. If the radius of the larger sphere is 9 cm, find the radius of the smaller sphere.

We may take the ratio of weights to be the same as the ratio of volumes.

$$\begin{aligned} \text{ratio of volumes } (k^3) &= \frac{32}{108} \\ &= \frac{8}{27} \end{aligned}$$

$$\begin{aligned} \text{ratio of corresponding lengths } (k) &= \sqrt[3]{\left(\frac{8}{27}\right)} \\ &= \frac{2}{3} \end{aligned}$$

$$\begin{aligned} \therefore \text{Radius of smaller sphere} &= \frac{2}{3} \times 9 \\ &= 6 \text{ cm} \end{aligned}$$

Exercise 9

In this exercise, the objects are similar and a number written inside a figure represents the volume of the object in cm^3 .

Numbers on the outside give linear dimensions in cm. In questions 1 to 8, find the unknown volume V .

1.

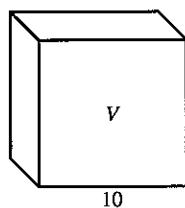
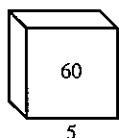

2.

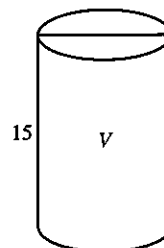

3.

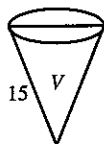

4.



radius = 1.2 cm

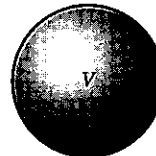

radius = 12 cm

5.

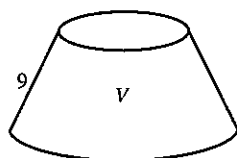

6.

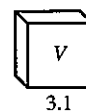
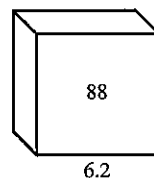

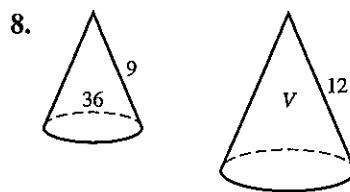
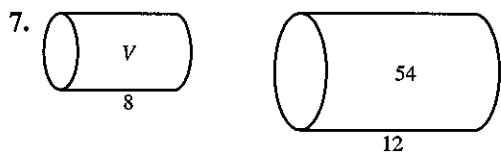

In questions 9 to 14, find the lengths marked by a letter.

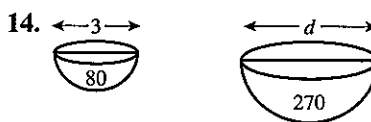
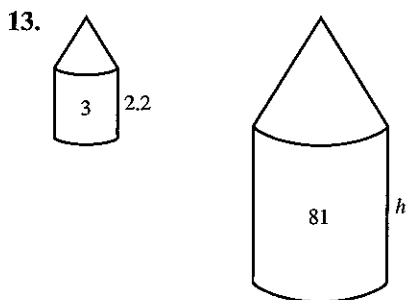
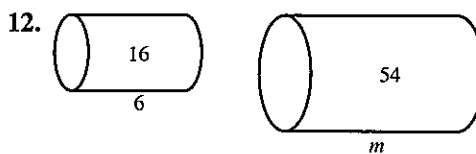
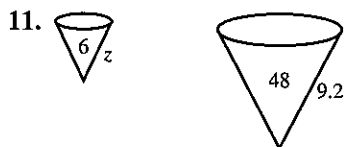
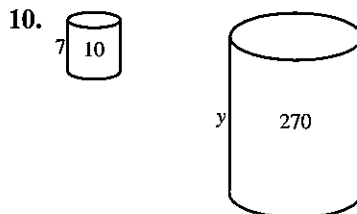
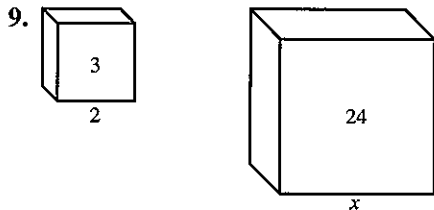

15. Two similar jugs have heights of 4 cm and 6 cm respectively. If the capacity of the smaller jug is 50 cm^3 , find the capacity of the larger jug.
16. Two similar cylindrical tins have base radii of 6 cm and 8 cm respectively. If the capacity of the larger tin is 252 cm^3 , find the capacity of the small tin.
17. Two solid metal spheres have masses of 5 kg and 135 kg respectively. If the radius of the smaller one is 4 cm, find the radius of the larger one.
18. Two similar cones have surface areas in the ratio 4 : 9. Find the ratio of:
 - (a) their lengths,
 - (b) their volumes.
19. The area of the bases of two similar glasses are in the ratio 4 : 25. Find the ratio of their volumes.
20. Two similar solids have volumes V_1 and V_2 and corresponding sides of length x_1 and x_2 . State the ratio $V_1 : V_2$ in terms of x_1 and x_2 .

21. Two solid spheres have surface areas of 5 cm^2 and 45 cm^2 respectively and the mass of the smaller sphere is 2 kg. Find the mass of the larger sphere.
22. The masses of two similar objects are 24 kg and 81 kg respectively. If the surface area of the larger object is 540 cm^2 , find the surface area of the smaller object.
23. A cylindrical can has a circumference of 40 cm and a capacity of 4.8 litres. Find the capacity of a similar cylinder of circumference 50 cm.
24. A container has a surface area of 5000 cm^2 and a capacity of 12.8 litres. Find the surface area of a similar container which has a capacity of 5.4 litres.

4.5 Circle theorems

- (a) The angle subtended at the centre of a circle is twice the angle subtended at the circumference.

$$\widehat{AOB} = 2 \times \widehat{ACB}$$

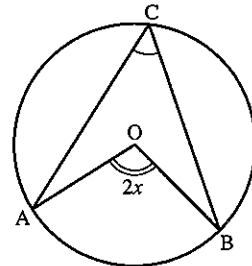

Proof:

Draw the straight line COD.

Let $\widehat{ACO} = y$ and $\widehat{BCO} = z$.

In triangle AOC,

- $AO = OC$ (radii)
- $\therefore \widehat{OCA} = \widehat{OAC}$ (isosceles triangle)
- $\therefore \widehat{COA} = 180 - 2y$ (angle sum of triangle)
- $\therefore \widehat{AOD} = 2y$ (angles on a straight line)

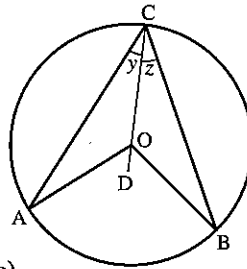

Similarly from triangle COB, we find

- $\widehat{DOB} = 2z$
- Now $\widehat{ACB} = y + z$
- and $\widehat{AOB} = 2y + 2z$
- $\therefore \widehat{AOB} = 2 \times \widehat{ACB}$ as required.

- (b) Angles subtended by an arc in the same segment of a circle are equal.

$$\widehat{AXB} = \widehat{AYB} = \widehat{AZB}$$

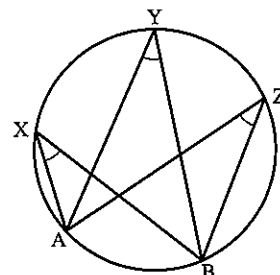

Example 1

Given $\widehat{ABO} = 50^\circ$, find \widehat{BCA} .

Triangle OBA is isosceles ($OA = OB$).

- $\therefore \widehat{OAB} = 50^\circ$
- $\therefore \widehat{BOA} = 80^\circ$ (angle sum of a triangle)
- $\therefore \widehat{BCA} = 40^\circ$ (angle at the circumference)

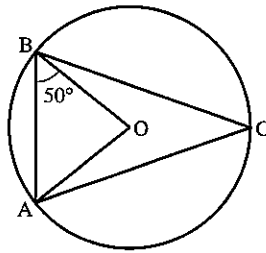

Example 2

Given $\widehat{BDC} = 62^\circ$ and $\widehat{DCA} = 44^\circ$, find \widehat{BAC} and \widehat{ABD} .

- $\widehat{BDC} = \widehat{BAC}$ (both subtended by arc BC)
- $\therefore \widehat{BAC} = 62^\circ$
- $\widehat{DCA} = \widehat{ABD}$ (both subtended by arc DA)
- $\therefore \widehat{ABD} = 44^\circ$

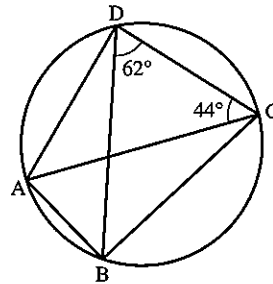

Exercise 10

Find the angles marked with letters. A line passes through the centre only when point O is shown.

1.

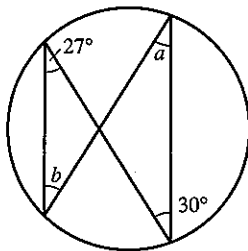

2.

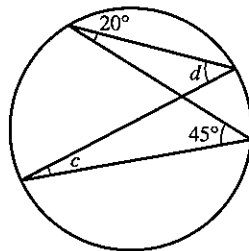

3.

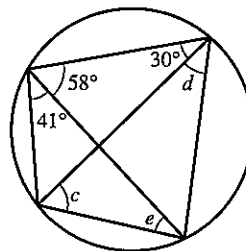

4.

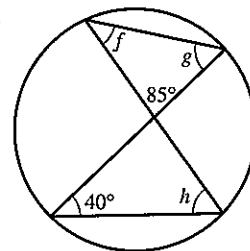

5.

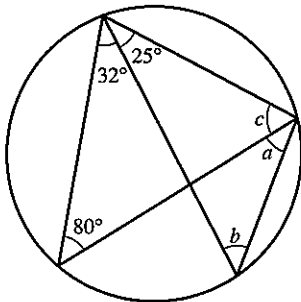

6.

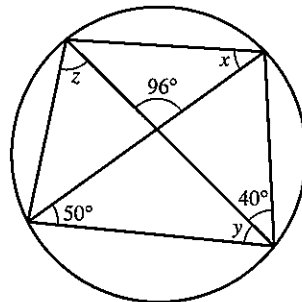

7.

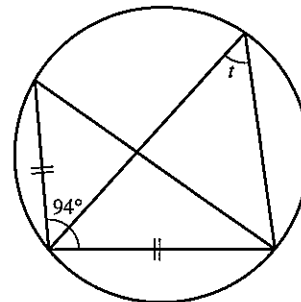

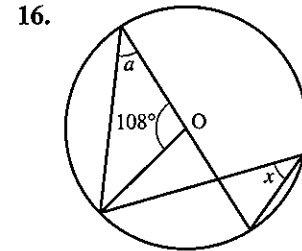
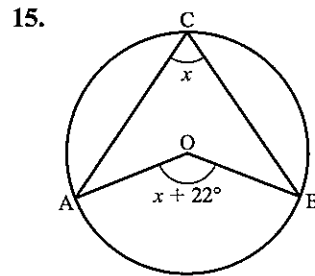
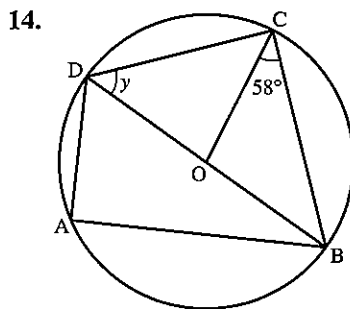
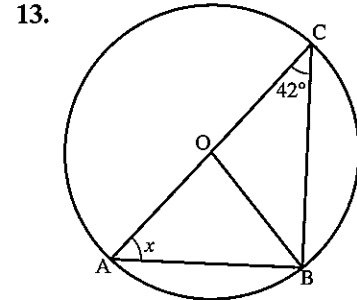
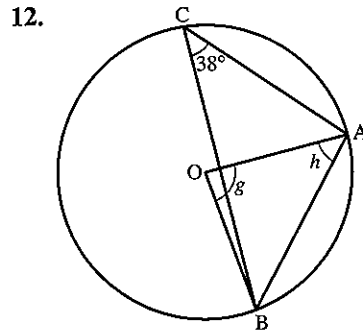
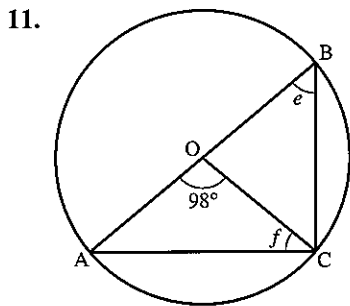
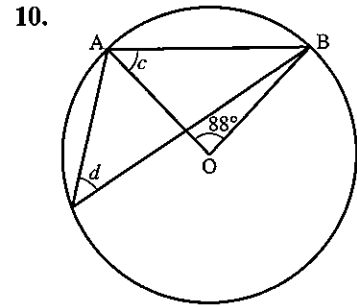
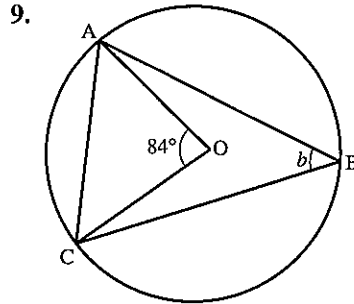
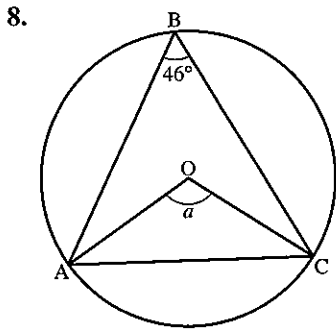

• ABCD is a cyclic quadrilateral. The corners touch the circle.

(c) The opposite angles in a cyclic quadrilateral add up to 180° (the angles are supplementary).

$$\begin{aligned} \hat{A} + \hat{C} &= 180^\circ \\ \hat{B} + \hat{D} &= 180^\circ \end{aligned}$$

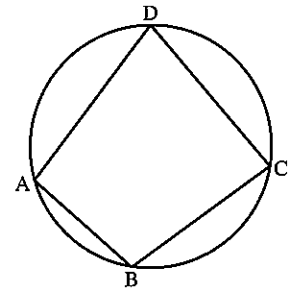

Proof:

Draw radii OA and OC.

Let $\hat{ADC} = x$ and $\hat{ABC} = y$.

\hat{AOC} obtuse = $2x$ (angle at the centre)

\hat{AOC} reflex = $2y$ (angle at the centre)

$\therefore 2x + 2y = 360^\circ$ (angles at a point)

$\therefore x + y = 180^\circ$ as required

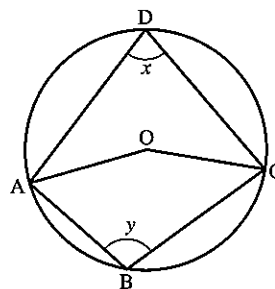

(d) The angle in a semi-circle is a right angle.

In the diagram, AB is a diameter.

$$\widehat{ACB} = 90^\circ.$$

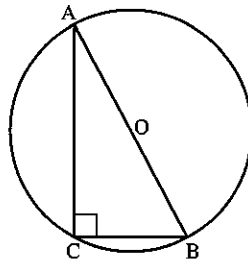

Example 1

Find a and x .

$$a = 180^\circ - 81^\circ \text{ (opposite angles of a cyclic quadrilateral)}$$

$$\therefore a = 99^\circ$$

$$x + 2x = 180^\circ \text{ (opposite angles of a cyclic quadrilateral)}$$

$$3x = 180^\circ$$

$$x = 60^\circ$$

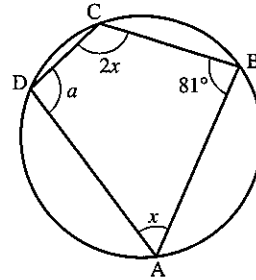

Example 2

Find b .

$$\widehat{ACB} = 90^\circ \text{ (angle in a semi-circle)}$$

$$\therefore b = 180^\circ - (90 + 37)^\circ = 53^\circ$$

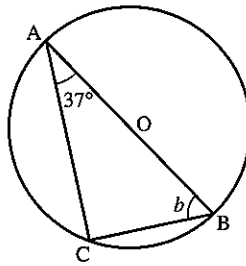

Exercise 11

Find the angles marked with a letter.

1.

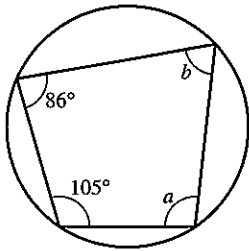

2.

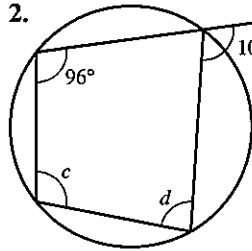

3.

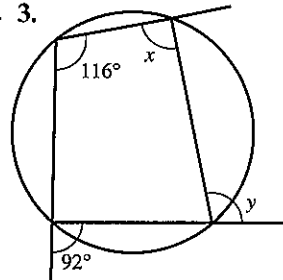

4.

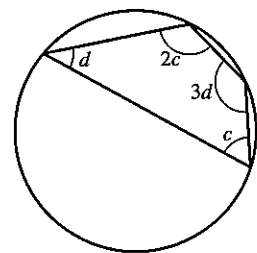

5.

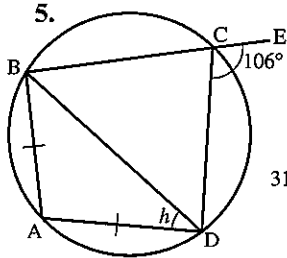

6.

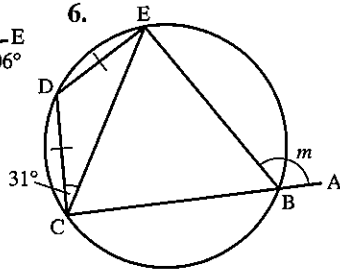

7.

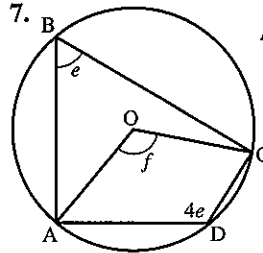

8.

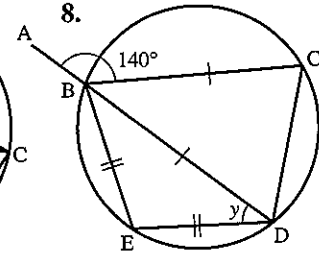

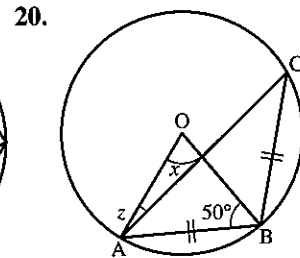
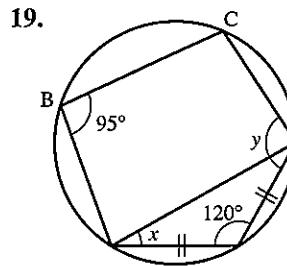
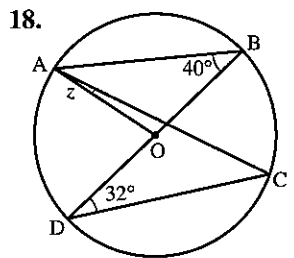
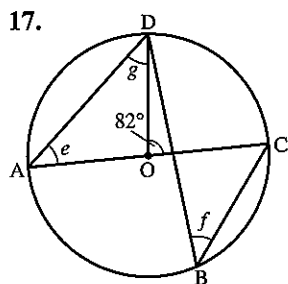
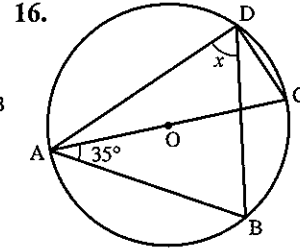
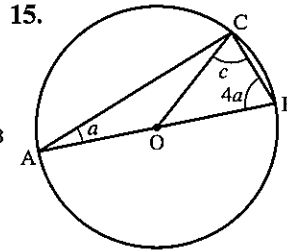
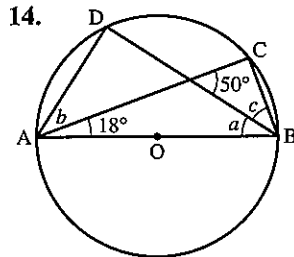
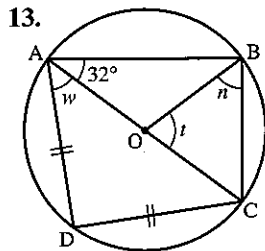
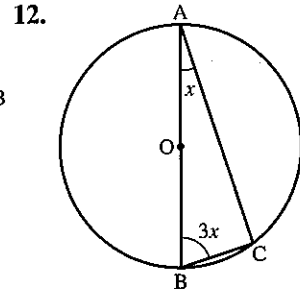
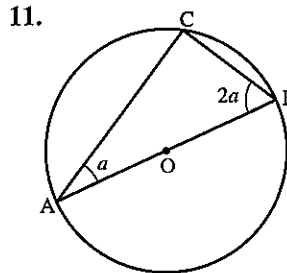
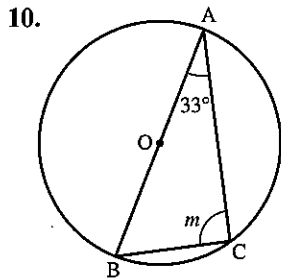
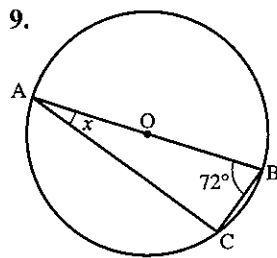

Tangents to circles

- (a) The angle between a tangent and the radius drawn to the point of contact is 90° .

$$\widehat{ABO} = 90^\circ$$

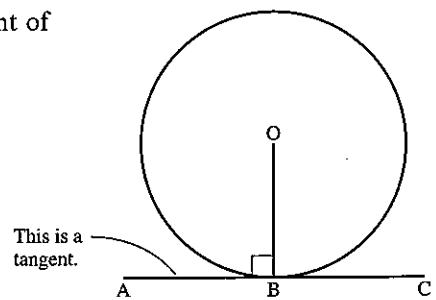

- (b) From any point outside a circle just two tangents to the circle may be drawn and they are of equal length.

$$TA = TB$$

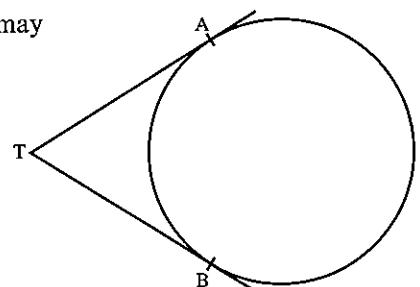

(c) Alternate segment theorem.

The angle between a tangent and a chord through the point of contact is equal to the angle subtended by the chord in the alternate segment.

$$\widehat{TAB} = \widehat{BCA}$$

and $\widehat{SAC} = \widehat{CBA}$

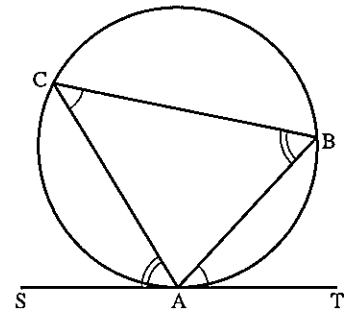

Example

TA and TB are tangents to the circle, centre O. Given $\widehat{ATB} = 50^\circ$, find

- (a) \widehat{ABT}
- (b) \widehat{OBA}
- (c) \widehat{ACB}

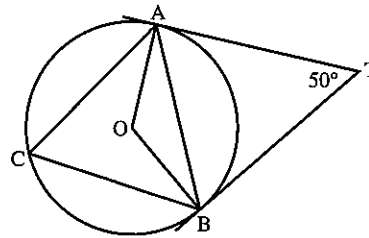

- (a) $\triangle TBA$ is isosceles ($TA = TB$)
 $\therefore \widehat{ABT} = \frac{1}{2}(180 - 50) = 65^\circ$
- (b) $\widehat{OBT} = 90^\circ$ (tangent and radius)
 $\therefore \widehat{OBA} = 90 - 65 = 25^\circ$
- (c) $\widehat{ACB} = \widehat{ABT}$ (alternate segment theorem)
 $\widehat{ACB} = 65^\circ$

Exercise 12

For questions 1 to 12, find the angles marked with a letter.

1.

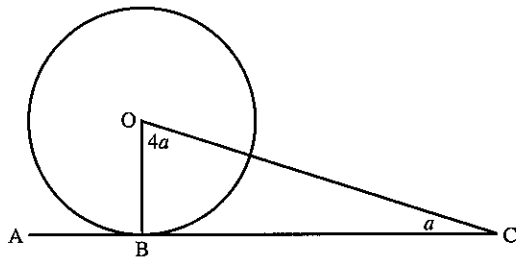

2.

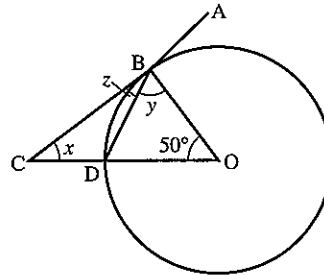

3.

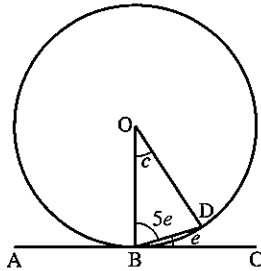

4.

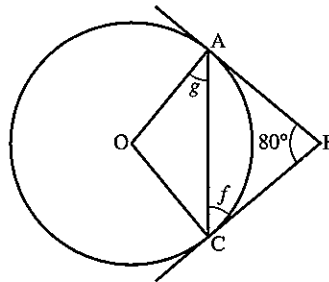

5.

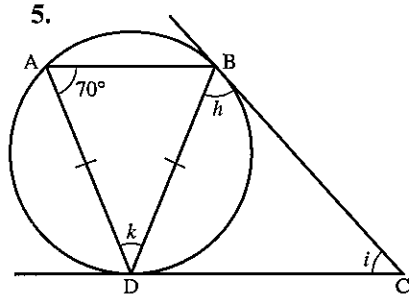

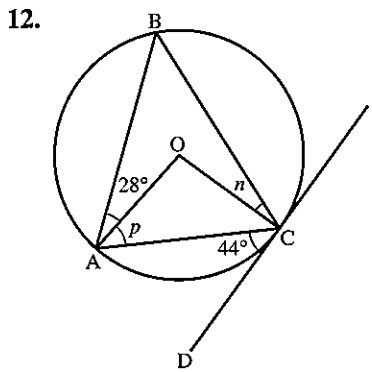
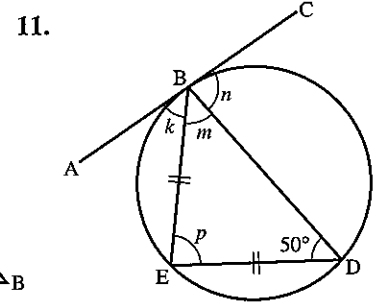
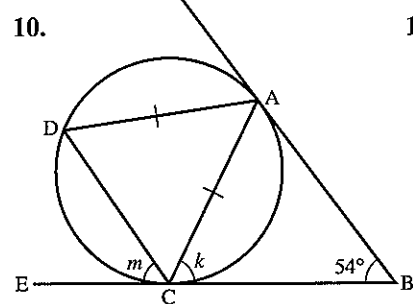
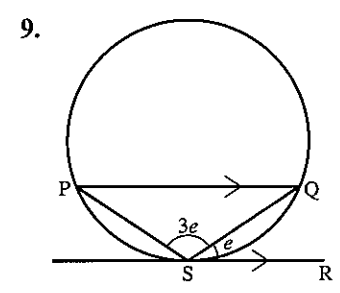
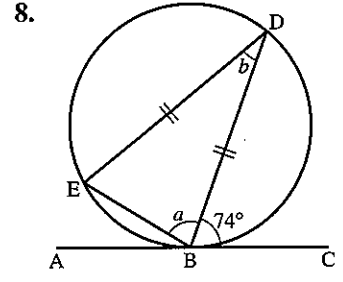
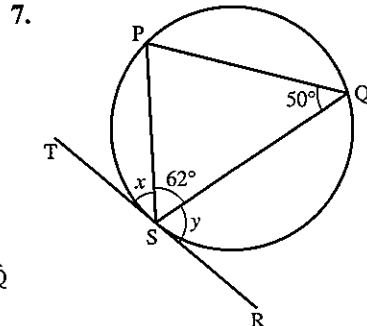
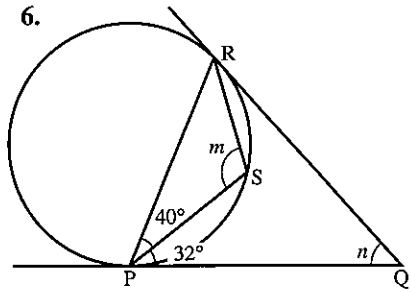

13. Find (a) \widehat{ADX} (b) \widehat{ABC} (c) \widehat{BCD}

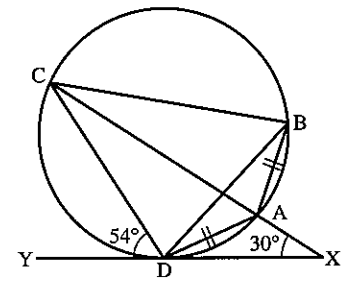

14. Find, in terms of p :
 (a) \widehat{BAC} (b) \widehat{XCA} (c) \widehat{ACO}

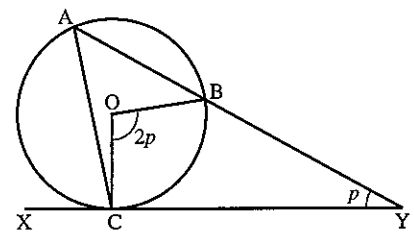

15. Find x , y and z .

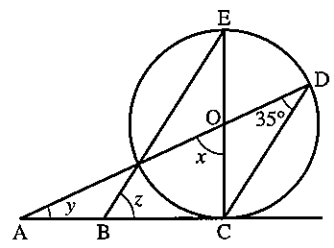

16. Given that $KL = LN$, LP bisects \widehat{KLN} and $\widehat{MKN} = a$:

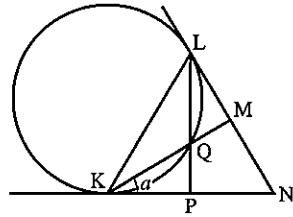

- (a) prove that $\triangle KQL$ is isosceles
 (b) find \widehat{LQM} and \widehat{LMQ} in terms of a .

17. Show that:

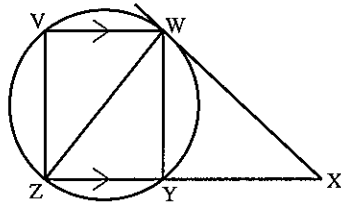

- (a) $\widehat{YWX} = \widehat{VWZ}$
 (b) the triangles VWZ and YWX are similar
 (c) $VW \times WX = YW \times WZ$
18. Given that BOC is a diameter and that $\widehat{ADC} = 90^\circ$, prove that AC bisects \widehat{BCD} .

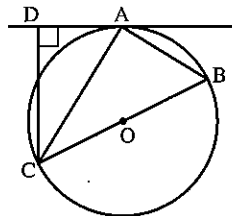

19. The angles of a triangle are 50° , 60° and 70° , and a circle touches the sides at A , B , C . Calculate the angles of triangle ABC .
20. The tangents at A and B on a circle intersect at T , and C is any point on the major arc AB .
- (a) If $\widehat{ATB} = 52^\circ$, calculate \widehat{ACB} .
 (b) If $\widehat{ACB} = x$, find \widehat{ATB} in terms of x .
21. Line ATB touches a circle at T and TC is a diameter. AC and BC cut the circle at D and E respectively. Prove that the quadrilateral $ADEB$ is cyclic.
22. Two circles touch externally at T . A chord of the first circle XY is produced and touches the other at Z . The chord ZT of the second circle, when produced, cuts the first circle at W . Prove that $\widehat{XTW} = \widehat{YTZ}$.

4.6 Constructions and loci

When the word 'construct' is used, the diagram should be drawn using equipment such as compasses, a ruler, a protractor etc.

Three basic constructions are shown below.

(a) Perpendicular bisector of a line joining two points

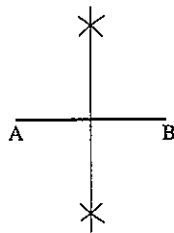

(b) Bisector of an angle

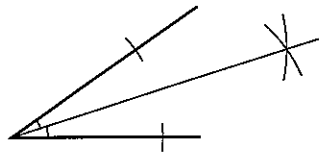

(c) 60° angle construction

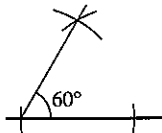

Exercise 13

1. Construct a triangle ABC in which $AB = 8$ cm, $AC = 6$ cm and $BC = 5$ cm. Measure the angle \widehat{ACB} .
2. Construct a triangle PQR in which $PQ = 10$ cm, $PR = 7$ cm and $RQ = 6$ cm. Measure the angle \widehat{RPQ} .
3. Construct an equilateral triangle of side 7 cm.
4. Draw a line AB of length 10 cm. Construct the perpendicular bisector of AB.
5. Draw two lines AB and AC of length 8 cm, where \widehat{BAC} is approximately 40° . Construct the line which bisects \widehat{BAC} .
6. Draw a line AB of length 12 cm and draw a point X approximately 6 cm above the middle of the line. Construct the line through X which is perpendicular to AB.
7. Construct an equilateral triangle ABC of side 9 cm. Construct a line through A to meet BC at 90° at the point D. Measure the length AD.

8. Construct the triangles shown and measure the length x .

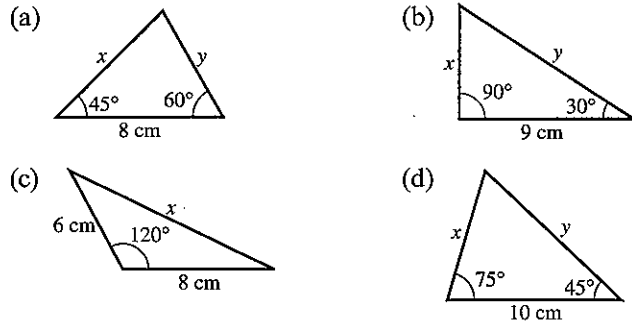

9. Construct a parallelogram $WXYZ$ in which $WX = 10$ cm, $WZ = 6$ cm and $\widehat{XWZ} = 60^\circ$. By construction, find the point A that lies on ZY and is equidistant from lines WZ and WX . Measure the length WA .

10. (a) Draw a line $OX = 10$ cm and construct an angle $XOY = 60^\circ$.
 (b) Bisect the angle XOY and mark a point A on the bisector so that $OA = 7$ cm.
 (c) Construct a circle with centre A to touch OX and OY and measure the radius of the circle.
11. (a) Construct a triangle PQR with $PQ = 8$ cm, $PR = 12$ cm and $\widehat{PQR} = 90^\circ$.
 (b) Construct the bisector of \widehat{QPR} .
 (c) Construct the perpendicular bisector of PR and mark the point X where this line meets the bisector of \widehat{QPR} .
 (d) Measure the length PX .
12. (a) Construct a triangle ABC in which $AB = 8$ cm, $AC = 6$ cm and $BC = 9$ cm.
 (b) Construct the bisector of \widehat{BAC} .
 (c) Construct the line through C perpendicular to CA and mark the point X where this line meets the bisector of \widehat{BAC} .
 (d) Measure the lengths CX and AX .

The locus of a point

The locus of a point is the path which it describes as it moves.

Example

Draw a line AB of length 8 cm.

Construct the locus of a point P which moves so that $\widehat{BAP} = 90^\circ$.

Construct the perpendicular at A .

This line is the locus of P .

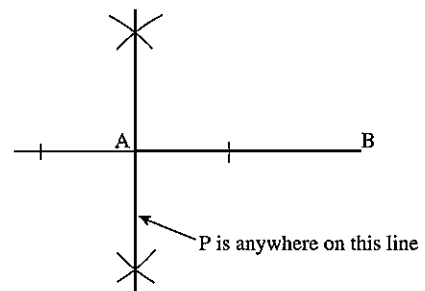

These are the basic loci you will come across:

1. Given distance from a given point. Locus is a circle.
2. Given distance from a straight line. Locus is a parallel line.
3. Equidistant from two given points. Locus is the perpendicular bisector of the line joining the two points.
4. Equidistant from two intersecting lines. Locus is the angle bisector of the two lines.

Exercise 14

1. Draw a line XY of length 10 cm. Construct the locus of a point which is equidistant from X and Y.
2. Draw two lines AB and AC of length 8 cm, where \widehat{BAC} is approximately 70° . Construct the locus of a point which is equidistant from the lines AB and AC.
3. Draw a circle, centre O, of radius 5 cm and draw a radius OA. Construct the locus of a point P which moves so that $\widehat{OAP} = 90^\circ$.
4. Draw a line AB of length 10 cm and construct the circle with diameter AB. Indicate the locus of a point P which moves so that $\widehat{APB} = 90^\circ$.
5. (a) Describe in words the locus of M, the tip of the minute hand of a clock as the time changes from 3 o'clock to 4 o'clock.
 (b) Sketch the locus of H, the tip of the hour hand, as the time changes from 3 o'clock to 4 o'clock.
 (c) Describe the locus of the tip of the second hand as the time goes from 3 o'clock to 4 o'clock.
6. Inspector Clouseau has put a radio transmitter on a suspect's car, which is parked somewhere in Paris. From the strength of the signals received at points R and P, Clouseau knows that the car is
 (a) not more than 40 km from R, and
 (b) not more than 20 km from P.

Make a scale drawing [1 cm \equiv 10 km] and show the possible positions of the suspect's car.

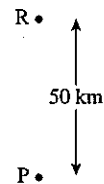

7. A treasure is buried in the rectangular garden shown. The treasure is: (a) within 4 m of A and (b) more than 3 m from the line AD. Draw a plan of the garden and shade the points where the treasure could be.

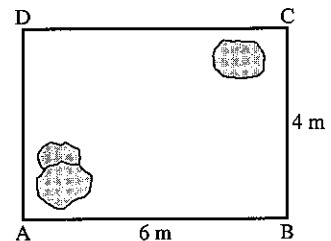

8. A goat is tied to one corner on the outside of a barn. The diagram shows a plan view. Sketch two plan views of the barn and show the locus of points where the goat can graze if
 (a) the rope is 4 m long,
 (b) the rope is 7 m long.

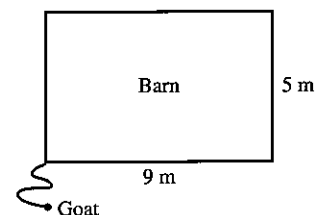

9. Draw a line AB of length 10 cm. With AB as base draw a triangle ABP so that the *area* of the triangle is 30 cm^2 . Describe the locus of P if P moves so that the area of the triangle ABP is always 30 cm^2 .

10. As the second hand of a clock goes through a vertical position, a money spider starts walking from C along the hand. After one minute the spider is at the top of the clock T. Describe the locus of the spider.

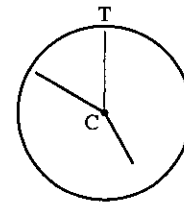

11. Sketch a side view of the locus of the valve on a bicycle wheel as the bicycle goes past in a straight line.

4.7 Nets

If the cube below was made of cardboard, and you cut along some of the edges and laid it out flat, you would have the *net* of the cube.

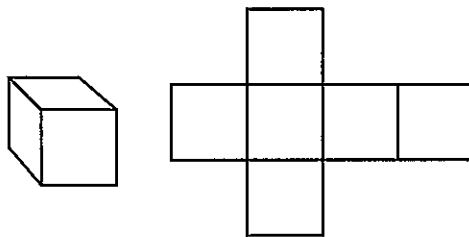

Exercise 15

1. Which of the nets below can be used to make a cube?

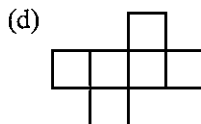
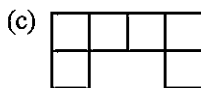
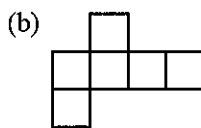
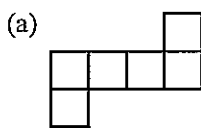

2. The diagram shows the net of a closed rectangular box. All lengths are in cm.

- (a) Find the lengths a , x , y
- (b) Calculate the volume of the box.

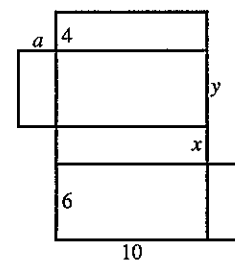

3. The diagram shows the net of a pyramid. The base is shaded. The lengths are in cm.

- (a) Find the lengths a, b, c, d
 (b) Find the volume of the pyramid.

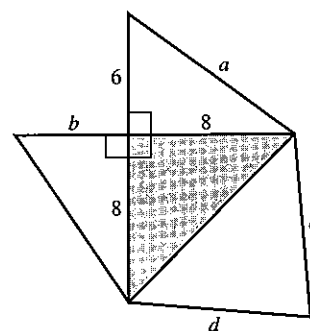

4. The diagram shows the net of a prism.
 (a) Find the area of one of the triangular faces (shown shaded).
 (b) Find the volume of the prism.

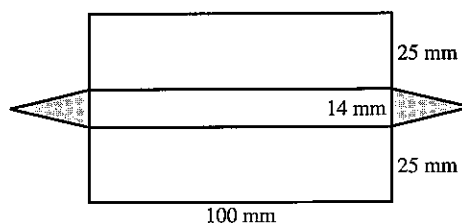

5. This is the net of a square-based pyramid.
 What are the lengths a, b, c, x, y ?

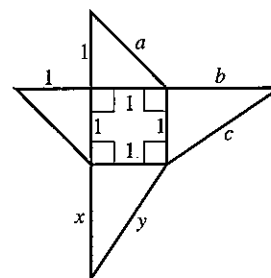

6. Sketch nets for the following:
 (a) Closed rectangular box $7\text{ cm} \times 9\text{ cm} \times 5\text{ cm}$.
 (b) Closed cylinder: length 10 cm , radius 6 cm .
 (c) Prism of length 12 cm , cross-section an equilateral triangle of side 4 cm .

Revision exercise 4A

1. ABCD is a parallelogram and AE bisects angle A. Prove that $DE = BC$.

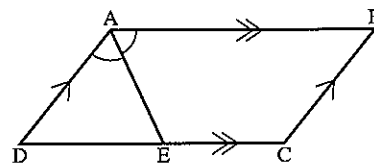

2. In a triangle PQR, $\widehat{PQR} = 50^\circ$ and point X lies on PQ such that $QX = XR$. Calculate \widehat{QXR} .
3. (a) ABCDEF is a regular hexagon. Calculate \widehat{FDE} .
 (b) ABCDEFGH is a regular eight-sided polygon. Calculate \widehat{AGH} .
 (c) Each interior angle of a regular polygon measures 150° . How many sides has the polygon?

4. In the quadrilateral PQRS, $PQ = QS = QR$, PS is parallel to QR and $\widehat{QRS} = 70^\circ$. Calculate:
 (a) \widehat{RQS}
 (b) \widehat{PQS}

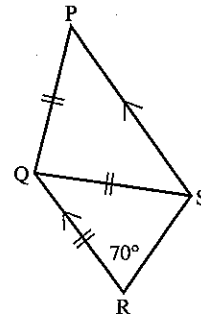

5. Find x .

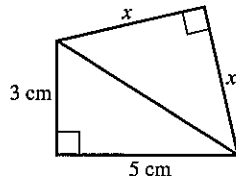

6. In the triangle ABC, $AB = 7$ cm, $BC = 8$ cm and $\widehat{ABC} = 90^\circ$. Point P lies inside the triangle such that $BP = PC = 5$ cm. Calculate:
 (a) the perpendicular distance from P to BC
 (b) the length AP
7. In triangle PQR the bisector of \widehat{PQR} meets PR at S and the point T lies on PQ such that ST is parallel to RQ.
 (a) Prove that $QT = TS$.
 (b) Prove that the triangles PTS and PQR are similar.
 (c) Given that $PT = 5$ cm and $TQ = 2$ cm, calculate the length of QR.
8. In the quadrilateral ABCD, AB is parallel to DC and $\widehat{DAB} = \widehat{DBC}$.
 (a) Prove that the triangles ABD and DBC are similar.
 (b) If $AB = 4$ cm and $DC = 9$ cm, calculate the length of BD.
9. A rectangle 11 cm by 6 cm is similar to a rectangle 2 cm by x cm. Find the two possible values of x .
10. In the diagram, triangles ABC and EBD are similar but DE is *not* parallel to AC. Given that $AD = 5$ cm, $DB = 3$ cm and $BE = 4$ cm, calculate the length of BC.

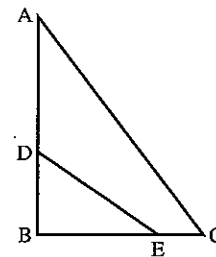

11. The radii of two spheres are in the ratio 2:5. The volume of the smaller sphere is 16 cm³. Calculate the volume of the larger sphere.
12. The surface areas of two similar jugs are 50 cm² and 450 cm² respectively.
 (a) If the height of the larger jug is 10 cm, find the height of the smaller jug.
 (b) If the volume of the smaller jug is 60 cm³, find the volume of the larger jug.

13. A car is an enlargement of a model, the scale factor being 10.
- If the windscreen of the model has an area of 100 cm^2 , find the area of the windscreen on the actual car (answer in m^2).
 - If the capacity of the boot of the car is 1 m^3 , find the capacity of the boot on the model (answer in cm^3).

14. Find the angles marked with letters. (O is the centre of the circle.)

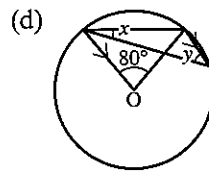
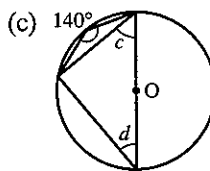
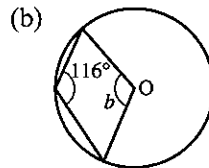
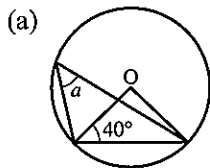

15. ABCD is a cyclic quadrilateral in which $AB = BC$ and $\widehat{ABC} = 70^\circ$. AD produced meets BC produced at the point P, where $\widehat{APB} = 30^\circ$. Calculate:
- \widehat{ADB}
 - \widehat{ABD}

16. Using ruler and compasses only:
- Construct the triangle ABC in which $AB = 7 \text{ cm}$, $BC = 5 \text{ cm}$ and $AC = 6 \text{ cm}$.
 - Construct the circle which passes through A, B and C and measure the radius of this circle.
17. Construct:
- the triangle XYZ in which $XY = 10 \text{ cm}$, $YZ = 11 \text{ cm}$ and $XZ = 9 \text{ cm}$.
 - the locus of points, inside the triangle, which are equidistant from the lines XZ and YZ.
 - the locus of points which are equidistant from Y and Z.
 - the circle which touches YZ at its mid-point and also touches XZ.

Examination exercise 4B

1. Two different quadrilaterals each have one, and only one, line of symmetry. In quadrilateral A, the line of symmetry is a diagonal. In quadrilateral B, the line of symmetry is not a diagonal. Draw each of the quadrilaterals, showing the line of symmetry, and write down their special names.

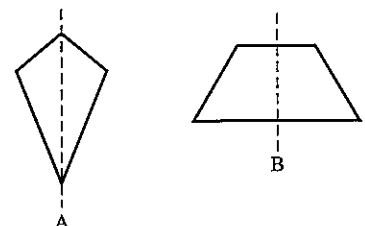

2.

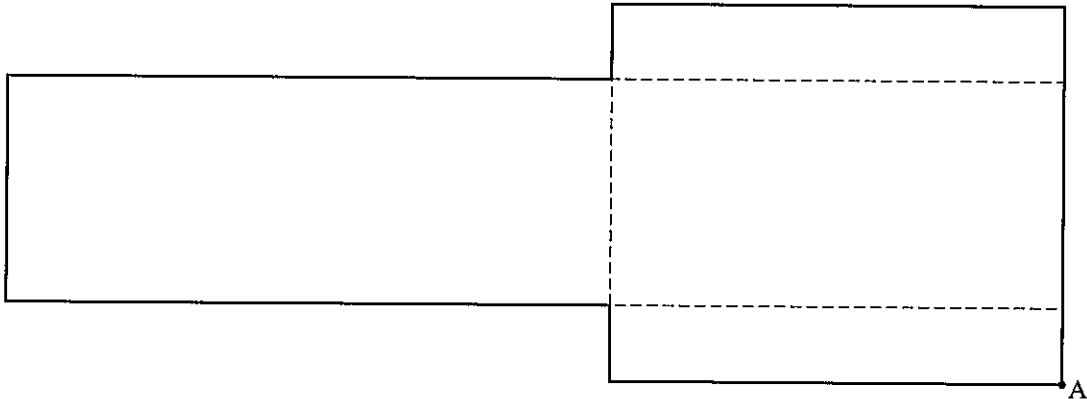

- (a) Copy the diagram and then draw two more broken lines to make it into the net of a cuboid.
 - (b) Mark clearly on the diagram the point A' which will touch the point A when the net is folded to make the cuboid. J 97 2
3. Show, by drawing and shading, the set of all points which are at least 2 cm from a point O but no more than 3 cm from it. N 97 2
4. A 'Pythagorean triple' is a set of three whole numbers that could be the lengths of the three sides of a right-angled triangle.
- (a) Show that $\{5, 12, 13\}$ is a Pythagorean triple.
 - (b) Two of the numbers in a Pythagorean triple are 24 and 25. Find the third number.
 - (c) The largest number in a Pythagorean triple is x and one of the other numbers is $x - 2$.
 - (i) If the third number is y , show that $y = \sqrt{4x - 4}$.
 - (ii) If $x = 50$, find the other two numbers in the triple.
 - (iii) If $x = 101$, find the other two numbers in the triple.
 - (iv) Find two other Pythagorean triples in the form $\{y, x - 2, x\}$, where $x < 40$. Remember that all three numbers must be whole numbers. N 97 4

5. Two table tops are similar in shape, as shown in the diagram.

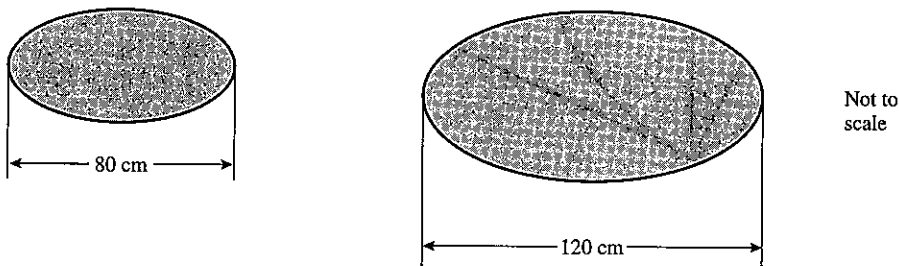

The area of the smaller one is $\frac{1}{4} \text{ m}^2$. Calculate the area of the larger one. N 97 2

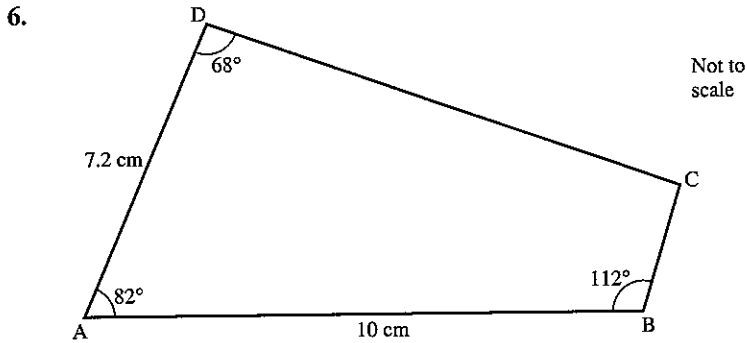

- (a) Draw the line AB, 10 cm long, in the centre of a new page. Construct a quadrilateral ABCD such that $AD = 7.2$ cm, angle $DAB = 82^\circ$, angle $ADC = 68^\circ$ and angle $ABC = 112^\circ$.
- (b) Use a straight edge and compasses only to construct the perpendicular bisectors of AB and AD. These meet at E. Leave all construction lines on your diagram.
- (c) (i) Measure and write down the length AE.
(ii) Construct the locus of all points which are this distance from E.
(iii) Write down the special name of quadrilateral ABCD.
- (d) Shade the region inside the quadrilateral which is nearer to A than it is to B, and nearer to A than it is to D. J 98 4

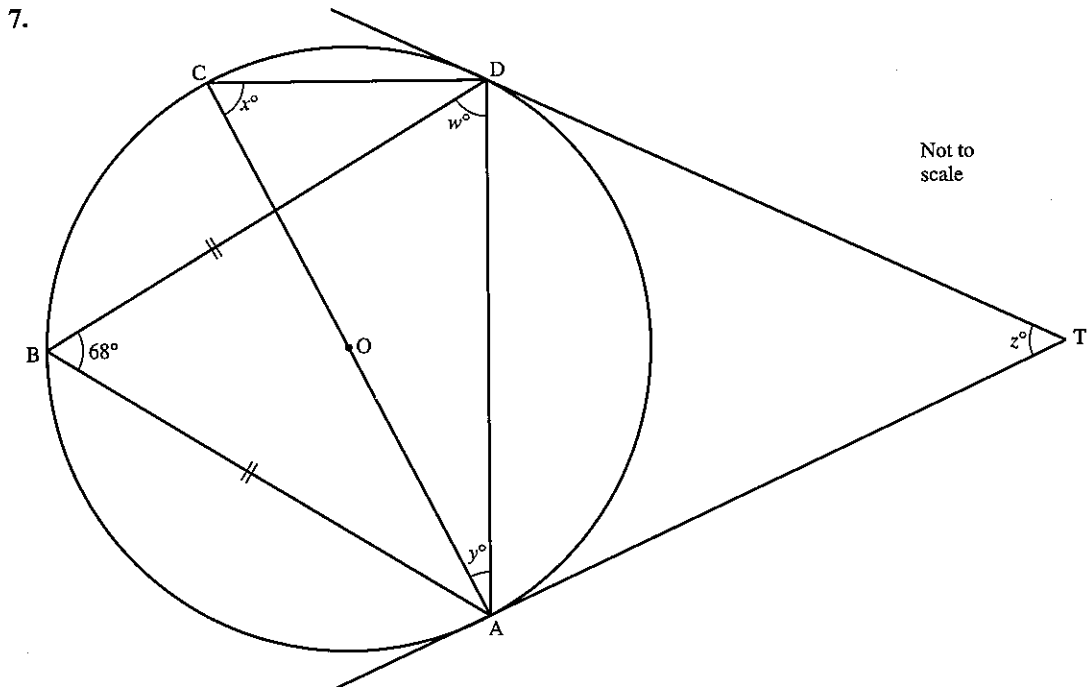

AOC is the diameter of circle ABCD.
 AT and DT are tangents. $BD = BA$ and angle $DBA = 68^\circ$.
 Find the angles marked w , x , y and z .

8. (a)

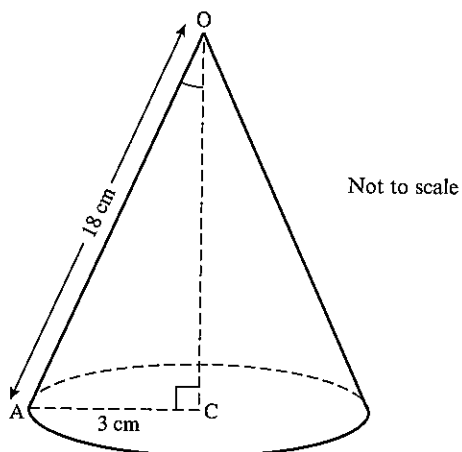

The diagram shows a hollow cone with base radius $AC = 3$ cm and edge $OA = 18$ cm. Calculate:

- (i) the height OC ,
- (ii) angle AOC ,
- (iii) the circumference of the base.
[π is approximately 3.142.]
- (iv) The cone is cut along the line OA and opened out to form the sector AOA' . Calculate
 - (a) the circumference of a circle of radius 18 cm,
 - (b) angle AOA' .

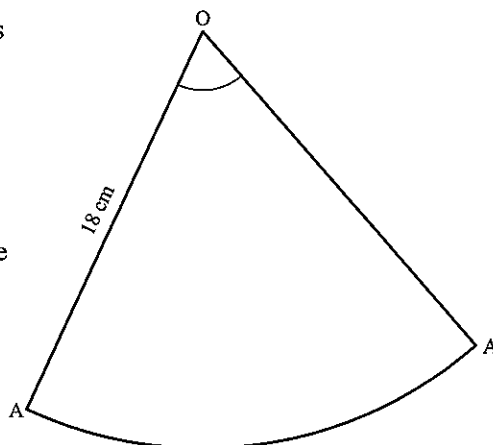

(b) The top part of a solid cone is removed. The height of the remaining solid is half the height of the original cone.

- (i) Write down, in the form $1 : n$, the ratios:
 - (a) the base radius of the cone removed : the base radius of the original cone,
 - (b) the curved surface area of the cone removed : the curved surface area of the original cone,
 - (c) the volume of the cone removed : the volume of the original cone.
- (ii) The curved surface area of the original cone was 24π cm². Calculate, in terms of π , the curved surface area of the remaining solid.
- (iii) The volume of the original cone was V cm³. Give the volume of the remaining solid in terms of V .

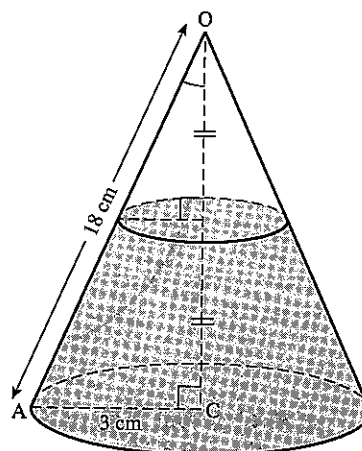

9.

Not to scale

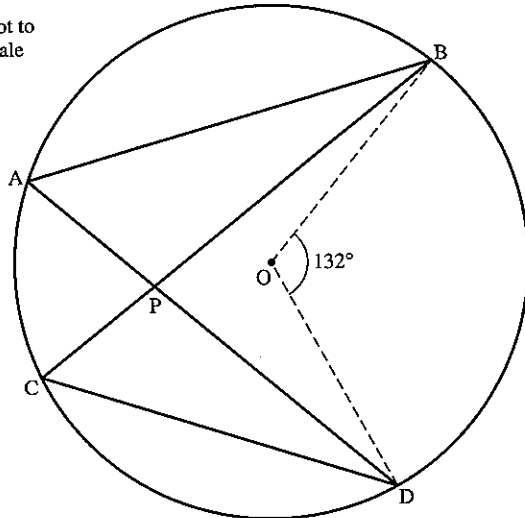

O is the centre of the circle. Angle $BOD = 132^\circ$. The chords AD and BC meet at P.

- (a)
 - (i) Calculate angles BAD and BCD.
 - (ii) Explain why triangles ABP and CDP are similar.
 - (iii) $AP = 6$ cm, $PD = 8$ cm, $CP = 3$ cm and $AB = 17.5$ cm. Calculate the lengths of PB and CD.
 - (iv) If the area of triangle ABP is n cm², write down, in terms of n , the area of triangle CPD.
- (b)
 - (i) The tangents at B and D meet at T. Calculate angle BTD.
 - (ii) Use $OB = 9.5$ cm to calculate the diameter of the circle which passes through O, B, T and D, giving your answer to the nearest centimetre.

N 95 4

10.

Not to scale

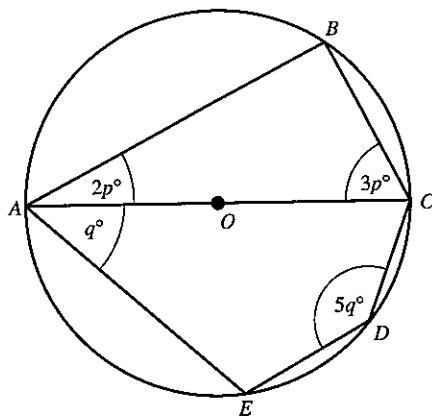

A, B, C, D and E lie on a circle, centre O. AOC is a diameter. Find the value of:

- (a) p ,
- (b) q .

J 03 2

5 ALGEBRA 2

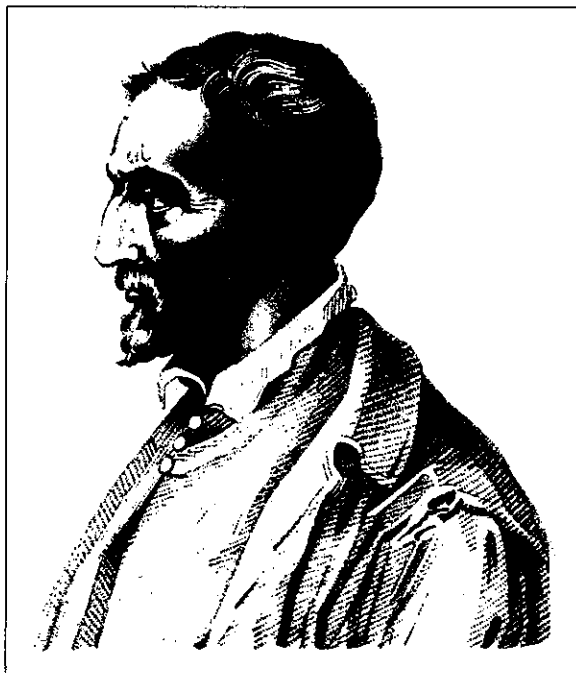

Girolamo Cardan (1501–1576) was a colourful character who became Professor of Mathematics at Milan. As well as being a distinguished academic, he was an astrologer, a physician, a gambler and a heretic, yet he received a pension from the Pope. His mathematical genius enabled him to open up the general theory of cubic and quartic equations, although a method for solving cubic equations which he claimed as his own was pirated from Niccolo Tartaglia.

- 10 Express direct and inverse variation in algebraic terms
- 20 Transform more complicated formulae
- 21 Manipulate algebraic fractions
- 23 Use indices, including fractional indices
- 24 Solve simple linear inequalities
- 25 Represent inequalities graphically and solve simple linear programming problems

5.1 Algebraic fractions

Simplifying fractions

Example

Simplify: (a) $\frac{32}{56}$ (b) $\frac{3a}{5a^2}$ (c) $\frac{3y + y^2}{6y}$

(a) $\frac{32}{56} = \frac{\cancel{8} \times 4}{\cancel{8} \times 7} = \frac{4}{7}$ (b) $\frac{3a}{5a^2} = \frac{3 \times \cancel{a}}{5 \times a \times \cancel{a}} = \frac{3}{5a}$ (c) $\frac{y(3 + y)}{6y} = \frac{3 + y}{6}$

Exercise 1

Simplify as far as possible, where you can.

- | | | |
|------------------------------|------------------------------|-------------------------------|
| 1. $\frac{25}{35}$ | 2. $\frac{84}{96}$ | 3. $\frac{5y^2}{y}$ |
| 4. $\frac{y}{2y}$ | 5. $\frac{8x^2}{2x^2}$ | 6. $\frac{2x}{4y}$ |
| 7. $\frac{6y}{3y}$ | 8. $\frac{5ab}{10b}$ | 9. $\frac{8ab^2}{12ab}$ |
| 10. $\frac{7a^2b}{35ab^2}$ | 11. $\frac{(2a)^2}{4a}$ | 12. $\frac{7yx}{8xy}$ |
| 13. $\frac{5x + 2x^2}{3x}$ | 14. $\frac{9x + 3}{3x}$ | 15. $\frac{25 + 7}{25}$ |
| 16. $\frac{4a + 5a^2}{5a}$ | 17. $\frac{3x}{4x - x^2}$ | 18. $\frac{5ab}{15a + 10a^2}$ |
| 19. $\frac{5x + 4}{8x}$ | 20. $\frac{12x + 6}{6y}$ | 21. $\frac{5x + 10y}{15xy}$ |
| 22. $\frac{18a - 3ab}{6a^2}$ | 23. $\frac{4ab + 8a^2}{2ab}$ | 24. $\frac{(2x)^2 - 8x}{4x}$ |

Example

Simplify:

$$(a) \frac{x^2 + x - 6}{x^2 + 2x - 3} = \frac{(x-2)\cancel{(x+3)}}{\cancel{(x+3)}(x-1)} = \frac{x-2}{x-1}$$

$$(b) \frac{x^2 + 3x - 10}{x^2 - 4} = \frac{\cancel{(x-2)}(x+5)}{\cancel{(x-2)}(x+2)} = \frac{x+5}{x+2}$$

$$(c) \frac{3x^2 - 9x}{x^2 - 4x + 3} = \frac{3x\cancel{(x-3)}}{(x-1)\cancel{(x-3)}} = \frac{3x}{x-1}$$

Exercise 2

Simplify as far as possible:

- | | | |
|---------------------------------------|--|--|
| 1. $\frac{x^2 + 2x}{x^2 - 3x}$ | 2. $\frac{x^2 - 3x}{x^2 - 2x - 3}$ | 3. $\frac{x^2 + 4x}{2x^2 - 10x}$ |
| 4. $\frac{x^2 + 6x + 5}{x^2 - x - 2}$ | 5. $\frac{x^2 - 4x - 21}{x^2 - 5x - 14}$ | 6. $\frac{x^2 + 7x + 10}{x^2 - 4}$ |
| 7. $\frac{x^2 + x - 2}{x^2 - x}$ | 8. $\frac{3x^2 - 6x}{x^2 + 3x - 10}$ | 9. $\frac{6x^2 - 2x}{12x^2 - 4x}$ |
| 10. $\frac{3x^2 + 15x}{x^2 - 25}$ | 11. $\frac{12x^2 - 20x}{4x^2}$ | 12. $\frac{x^2 + x - 6}{x^2 + 2x - 3}$ |

Addition and subtraction of algebraic fractions

Example

Write as a single fraction:

$$(a) \frac{2}{3} + \frac{3}{4} \qquad (b) \frac{2}{x} + \frac{3}{y}$$

Compare these two workings line for line:

$$(a) \frac{2}{3} + \frac{3}{4}; \text{ the L.C.M. of 3 and 4 is 12.}$$

$$\begin{aligned} \therefore \frac{2}{3} + \frac{3}{4} &= \frac{8}{12} + \frac{9}{12} \\ &= \frac{17}{12} \end{aligned}$$

$$(b) \frac{2}{x} + \frac{3}{y}; \text{ the L.C.M. of } x \text{ and } y \text{ is } xy.$$

$$\begin{aligned} \therefore \frac{2}{x} + \frac{3}{y} &= \frac{2y}{xy} + \frac{3x}{xy} \\ &= \frac{2y + 3x}{xy} \end{aligned}$$

Exercise 3

Simplify the following:

- | | | |
|--------------------------------------|-------------------------------------|--------------------------------------|
| 1. $\frac{2}{5} + \frac{1}{5}$ | 2. $\frac{2x}{5} + \frac{x}{5}$ | 3. $\frac{2}{x} + \frac{1}{x}$ |
| 4. $\frac{1}{7} + \frac{3}{7}$ | 5. $\frac{x}{7} + \frac{3x}{7}$ | 6. $\frac{1}{7x} + \frac{3}{7x}$ |
| 7. $\frac{5}{8} + \frac{1}{4}$ | 8. $\frac{5x}{8} + \frac{x}{4}$ | 9. $\frac{5}{8x} + \frac{1}{4x}$ |
| 10. $\frac{2}{3} + \frac{1}{6}$ | 11. $\frac{2x}{3} + \frac{x}{6}$ | 12. $\frac{2}{3x} + \frac{1}{6x}$ |
| 13. $\frac{3}{4} + \frac{2}{5}$ | 14. $\frac{3x}{4} + \frac{2x}{5}$ | 15. $\frac{3}{4x} + \frac{2}{5x}$ |
| 16. $\frac{3}{4} - \frac{2}{3}$ | 17. $\frac{3x}{4} - \frac{2x}{3}$ | 18. $\frac{3}{4x} - \frac{2}{3x}$ |
| 19. $\frac{x}{2} + \frac{x+1}{3}$ | 20. $\frac{x-1}{3} + \frac{x+2}{4}$ | 21. $\frac{2x-1}{5} + \frac{x+3}{2}$ |
| 22. $\frac{x+1}{3} - \frac{2x+1}{4}$ | 23. $\frac{x-3}{3} - \frac{x-2}{5}$ | 24. $\frac{2x+1}{7} - \frac{x+2}{2}$ |
| 25. $\frac{1}{x} + \frac{2}{x+1}$ | 26. $\frac{3}{x-2} + \frac{4}{x}$ | 27. $\frac{5}{x-2} + \frac{3}{x+3}$ |
| 28. $\frac{7}{x+1} - \frac{3}{x+2}$ | 29. $\frac{2}{x+3} - \frac{5}{x-1}$ | 30. $\frac{3}{x-2} - \frac{4}{x+1}$ |

5.2 Changing the subject of a formula

The operations involved in solving ordinary linear equations are exactly the same as the operations required in changing the subject of a formula.

Example 1

- (a) Solve the equation $3x + 1 = 12$.
 (b) Make x the subject of the formula $Mx + B = A$.

$$\begin{aligned} \text{(a)} \quad 3x + 1 &= 12 \\ 3x &= 12 - 1 \\ x &= \frac{12 - 1}{3} = \frac{11}{3} \end{aligned}$$

$$\begin{aligned} \text{(b)} \quad Mx + B &= A \\ Mx &= A - B \\ x &= \frac{A - B}{M} \end{aligned}$$

Example 2

- (a) Solve the equation $3(y - 2) = 5$.
 (b) Make y the subject of the formula $x(y - a) = e$.

$$\begin{aligned} \text{(a)} \quad 3(y - 2) &= 5 \\ 3y - 6 &= 5 \\ 3y &= 11 \\ y &= \frac{11}{3} \end{aligned}$$

$$\begin{aligned} \text{(b)} \quad x(y - a) &= e \\ xy - xa &= e \\ xy &= e + xa \\ y &= \frac{e + xa}{x} \end{aligned}$$

Exercise 4

Make x the subject of the following:

- | | | |
|---------------------|---------------------|--------------------|
| 1. $2x = 5$ | 2. $7x = 21$ | 3. $Ax = B$ |
| 4. $Nx = T$ | 5. $Mx = K$ | 6. $xy = 4$ |
| 7. $Bx = C$ | 8. $4x = D$ | 9. $9x = T + N$ |
| 10. $Ax = B - R$ | 11. $Cx = R + T$ | 12. $Lx = N - R^2$ |
| 13. $R - S^2 = Nx$ | 14. $x + 5 = 7$ | 15. $x + 10 = 3$ |
| 16. $x + A = T$ | 17. $x + B = S$ | 18. $N = x + D$ |
| 19. $M = x + B$ | 20. $L = x + D^2$ | 21. $N^2 + x = T$ |
| 22. $L + x = N + M$ | 23. $Z + x = R - S$ | 24. $x - 5 = 2$ |
| 25. $x - R = A$ | 26. $x - A = E$ | 27. $F = x - B$ |
| 28. $F^2 = x - B^2$ | 29. $x - D = A + B$ | 30. $x - E = A^2$ |

Make y the subject of the following:

31. $L = y - B$

34. $2y - 4 = 5$

37. $Dy + E = F$

40. $Ry - L = B$

43. $qy + n = s - t$

46. $r = ny - 6$

49. $j = my + c$

52. $A(y + B) = C$

55. $b(y - d) = q$

58. $z = S(y + t)$

32. $N = y - T$

35. $Ay + C = N$

38. $Ny - F = H$

41. $Vy + m = Q$

44. $ny - s^2 = t$

47. $s = my + d$

50. $2(y + 1) = 6$

53. $D(y + E) = F$

56. $n = r(y + t)$

59. $s = v(y - d)$

33. $3y + 1 = 7$

36. $By + D = L$

39. $Yy - Z = T$

42. $ty - m = n + a$

45. $V^2y + b = c$

48. $t = my - b$

51. $3(y - 1) = 5$

54. $h(y + n) = a$

57. $t(y - 4) = b$

60. $g = m(y + n)$

Example 1

(a) Solve the equation $\frac{3a + 1}{2} = 4$.

(b) Make a the subject of the formula $\frac{na + b}{m} = n$.

(a) $\frac{3a + 1}{2} = 4$

$3a + 1 = 8$

$3a = 7$

$a = \frac{7}{3}$

(b) $\frac{na + b}{m} = n$

$na + b = mn$

$na = mn - b$

$a = \frac{mn - b}{n}$

Example 2

Make a the subject of the formula

$x - na = y$

Make the ' a ' term positive

$x = y + na$

$x - y = na$

$\frac{x - y}{n} = a$

Exercise 5

Make a the subject.

1. $\frac{a}{4} = 3$

4. $\frac{a}{B} = T$

7. $\frac{a - 2}{4} = 6$

10. $\frac{a + Q}{N} = B^2$

13. $\frac{Aa + B}{C} = D$

2. $\frac{a}{5} = 2$

5. $\frac{a}{N} = R$

8. $\frac{a - A}{B} = T$

11. $g = \frac{a - r}{e}$

14. $\frac{na + m}{p} = q$

3. $\frac{a}{D} = B$

6. $b = \frac{a}{m}$

9. $\frac{a - D}{N} = A$

12. $\frac{2a + 1}{5} = 2$

15. $\frac{ra - t}{S} = v$

16. $\frac{za - m}{q} = t$

19. $n = \frac{ea - f}{h}$

22. $7 - a = 9$

25. $C - a = E$

28. $t = q - a$

31. $t = m - a$

34. $M - Na = Q$

37. $r = v^2 - ra$

40. $\frac{3 - 4a}{2} = 1$

43. $\frac{D - Ea}{N} = B$

46. $\frac{M(a + B)}{N} = T$

49. $\frac{y(x - a)}{z} = t$

17. $\frac{m + Aa}{b} = c$

20. $q = \frac{ga + b}{r}$

23. $5 = 7 - a$

26. $D - a = H$

29. $b = s - a$

32. $5 - 2a = 1$

35. $V - Ma = T$

38. $t^2 = w - na$

41. $\frac{5 - 7a}{3} = 2$

44. $\frac{h - fa}{b} = x$

47. $\frac{f(Na - e)}{m} = B$

50. $\frac{k^2(m - a)}{x} = x$

18. $A = \frac{Ba + D}{E}$

21. $6 - a = 2$

24. $A - a = B$

27. $n - a = m$

30. $v = r - a$

33. $T - Xa = B$

36. $L = N - Ra$

39. $n - qa = 2$

42. $\frac{B - Aa}{D} = E$

45. $\frac{v^2 - ha}{C} = d$

48. $\frac{T(M - a)}{E} = F$

Example 1(a) Solve the equation $\frac{4}{z} = 7$.(b) Make z the subject of the formula $\frac{n}{z} = k$.

(a) $\frac{4}{z} = 7$
 $4 = 7z$
 $\frac{4}{7} = z$

(b) $\frac{n}{z} = k$
 $n = kz$
 $\frac{n}{k} = z$

Example 2Make t the subject of the formula $\frac{x}{t} + m = a$.

$$\frac{x}{t} = a - m$$

$$x = (a - m)t$$

$$\frac{x}{(a - m)} = t$$

Exercise 6Make a the subject.

1. $\frac{7}{a} = 14$

2. $\frac{5}{a} = 3$

3. $\frac{B}{a} = C$

4. $\frac{T}{a} = X$

5. $\frac{M}{a} = B$

6. $m = \frac{n}{a}$

7. $t = \frac{v}{a}$

8. $\frac{n}{a} = \sin 20^\circ$

- | | | | |
|----------------------------------|---------------------------------|---------------------------------|---------------------------------|
| 9. $\frac{7}{a} = \cos 30^\circ$ | 10. $\frac{B}{a} = x$ | 11. $\frac{5}{a} = \frac{3}{4}$ | 12. $\frac{N}{a} = \frac{B}{D}$ |
| 13. $\frac{H}{a} = \frac{N}{M}$ | 14. $\frac{t}{a} = \frac{b}{e}$ | 15. $\frac{v}{a} = \frac{m}{s}$ | 16. $\frac{t}{b} = \frac{m}{a}$ |
| 17. $\frac{5}{a+1} = 2$ | 18. $\frac{7}{a-1} = 3$ | 19. $\frac{B}{a+D} = C$ | 20. $\frac{Q}{a-C} = T$ |
| 21. $\frac{V}{a-T} = D$ | 22. $\frac{L}{Ma} = B$ | 23. $\frac{N}{Ba} = C$ | 24. $\frac{m}{ca} = d$ |
| 25. $t = \frac{b}{c-a}$ | 26. $x = \frac{z}{y-a}$ | | |

Make x the subject.

- | | | | |
|-----------------------------|-----------------------------|------------------------------|------------------------------|
| 27. $\frac{2}{x} + 1 = 3$ | 28. $\frac{5}{x} - 2 = 4$ | 29. $\frac{A}{x} + B = C$ | 30. $\frac{V}{x} + G = H$ |
| 31. $\frac{r}{x} - t = n$ | 32. $q = \frac{b}{x} + d$ | 33. $t = \frac{m}{x} - n$ | 34. $h = d - \frac{b}{x}$ |
| 35. $C - \frac{d}{x} = e$ | 36. $r - \frac{m}{x} = e^2$ | 37. $t^2 = b - \frac{n}{x}$ | 38. $\frac{d}{x} + b = mn$ |
| 39. $\frac{M}{x+q} - N = 0$ | 40. $\frac{Y}{x-c} - T = 0$ | 41. $3M = M + \frac{N}{P+x}$ | 42. $A = \frac{B}{c+x} - 5A$ |
| 43. $\frac{K}{Mx} + B = C$ | 44. $\frac{z}{xy} - z = y$ | 45. $\frac{m^2}{x} - n = -p$ | 46. $t = w - \frac{q}{x}$ |

Example

Make x the subject of the formulae.

- (a) $\sqrt{x^2 + A} = B$
 $x^2 + A = B^2$ (square both sides)
 $x^2 = B^2 - A$
 $x = \pm\sqrt{B^2 - A}$
- (b) $(Ax - B)^2 = M$
 $Ax - B = \pm\sqrt{M}$ (square root both sides)
 $Ax = B \pm \sqrt{M}$
 $x = \frac{B \pm \sqrt{M}}{A}$
- (c) $\sqrt{R - x} = T$
 $R - x = T^2$
 $R = T^2 + x$
 $R - T^2 = x$

Exercise 7

Make x the subject.

- | | | | |
|------------------------------|------------------------|----------------------|-----------------------|
| 1. $\sqrt{x} = 2$ | 2. $\sqrt{x+1} = 5$ | 3. $\sqrt{x-2} = 3$ | 4. $\sqrt{x+a} = B$ |
| 5. $\sqrt{x+C} = D$ | 6. $\sqrt{x-E} = H$ | 7. $\sqrt{ax+b} = c$ | 8. $\sqrt{x-m} = a$ |
| 9. $b = \sqrt{gx-t}$ | 10. $r = \sqrt{b-x}$ | 11. $\sqrt{d-x} = t$ | 12. $b = \sqrt{x-d}$ |
| 13. $c = \sqrt{n-x}$ | 14. $f = \sqrt{b-x}$ | 15. $g = \sqrt{c-x}$ | 16. $\sqrt{M-Nx} = P$ |
| 17. $\sqrt{Ax+B} = \sqrt{D}$ | 18. $\sqrt{x-D} = A^2$ | 19. $x^2 = g$ | 20. $x^2 + 1 = 17$ |

21. $x^2 = B$

25. $C - x^2 = m$

22. $x^2 + A = B$

26. $n = d - x^2$

23. $x^2 - A = M$

27. $mx^2 = n$

24. $b = a + x^2$

28. $b = ax^2$

Make k the subject.

29. $\frac{kz}{a} = t$

33. $\sqrt{(k^2 - A)} = B$

37. $A\sqrt{(k + B)} = M$

41. $\sqrt{(a^2 - k^2)} = t$

45. $\sqrt{(ak^2 - b)} = C$

49. $\sqrt{(c^2 - ak)} = b$

30. $ak^2 - t = m$

34. $\sqrt{(k^2 + y)} = x$

38. $\sqrt{\left(\frac{M}{k}\right)} = N$

42. $\sqrt{(m - k^2)} = x$

46. $a\sqrt{(k^2 - x)} = b$

50. $\frac{m}{k^2} = a + b$

31. $n = a - k^2$

35. $t = \sqrt{(m + k^2)}$

39. $\sqrt{\left(\frac{N}{k}\right)} = B$

43. $2\pi\sqrt{(k + t)} = 4$

47. $k^2 + b = x^2$

32. $\sqrt{(k^2 - 4)} = 6$

36. $2\sqrt{(k + 1)} = 6$

40. $\sqrt{(a - k)} = b$

44. $A\sqrt{(k + 1)} = B$

48. $\frac{k^2}{a} + b = c$

Example

Make x the subject of the formulae.

(a) $Ax - B = Cx + D$

$Ax - Cx = D + B$

$x(A - C) = D + B$ (factorise)

$x = \frac{D + B}{A - C}$

(b) $x + a = \frac{x + b}{c}$

$c(x + a) = x + b$

$cx + ca = x + b$

$cx - x = b - ca$

$x(c - 1) = b - ca$ (factorise)

$x = \frac{b - ca}{c - 1}$

Exercise 8

Make y the subject.

1. $5(y - 1) = 2(y + 3)$

4. $My - D = E - 2My$

7. $xy + 4 = 7 - ky$

10. $m(y + a) = n(y + b)$

13. $\frac{1 - y}{1 + y} = \frac{c}{d}$

16. $y + m = \frac{2y - 5}{m}$

19. $\frac{ay + x}{x} = 4 - y$

22. $y(m + n) = a(y + b)$

2. $7(y - 3) = 4(3 - y)$

5. $ay + b = 3b + by$

8. $Ry + D = Ty + C$

11. $x(y - b) = y + d$

14. $\frac{M - y}{M + y} = \frac{a}{b}$

17. $y - n = \frac{y + 2}{n}$

20. $c - dy = e - ay$

23. $t - ay = s - by$

3. $Ny + B = D - Ny$

6. $my - c = e - ny$

9. $ay - x = z + by$

12. $\frac{a - y}{a + y} = b$

15. $m(y + n) = n(n - y)$

18. $y + b = \frac{ay + e}{b}$

21. $y(a - c) = by + d$

24. $\frac{y + x}{y - x} = 3$

25. $\frac{v-y}{v+y} = \frac{1}{2}$

26. $y(b-a) = a(y+b+c)$

27. $\sqrt{\left(\frac{y+x}{y-x}\right)} = 2$

28. $\sqrt{\left(\frac{z+y}{z-y}\right)} = \frac{1}{3}$

29. $\sqrt{\left[\frac{m(y+n)}{y}\right]} = p$

30. $n-y = \frac{4y-n}{m}$

Example

Make w the subject of the formula $\sqrt{\left(\frac{w}{w+a}\right)} = c$.

Squaring both sides, $\frac{w}{w+a} = c^2$

Multiplying by $(w+a)$, $w = c^2(w+a)$

$$\begin{aligned} w &= c^2w + c^2a \\ w - c^2w &= c^2a \\ w(1 - c^2) &= c^2a \\ w &= \frac{c^2a}{1 - c^2} \end{aligned}$$

Exercise 9

Make the letter in square brackets the subject.

1. $ax + by + c = 0$ [x]

2. $\sqrt{a(y^2 - b)} = e$ [y]

3. $\frac{\sqrt{(k-m)}}{n} = \frac{1}{m}$ [k]

4. $a - bz = z + b$ [z]

5. $\frac{x+y}{x-y} = 2$ [x]

6. $\sqrt{\left(\frac{a}{z} - c\right)} = e$ [z]

7. $lm + mn + a = 0$ [n]

8. $t = 2\pi\sqrt{\left(\frac{d}{g}\right)}$ [d]

9. $t = 2\pi\sqrt{\left(\frac{d}{g}\right)}$ [g]

10. $\sqrt{(x^2 + a)} = 2x$ [x]

11. $\sqrt{\left\{\frac{b(m^2 + a)}{e}\right\}} = t$ [m]

12. $\sqrt{\left(\frac{x+1}{x}\right)} = a$ [x]

13. $a + b - mx = 0$ [m]

14. $\sqrt{(a^2 + b^2)} = x^2$ [a]

15. $\frac{a}{k} + b = \frac{c}{k}$ [k]

16. $a - y = \frac{b+y}{a}$ [y]

17. $G = 4\pi\sqrt{(x^2 + T^2)}$ [x]

18. $M(ax + by + c) = 0$ [y]

19. $x = \sqrt{\left(\frac{y-1}{y+1}\right)}$ [y]

20. $a\sqrt{\left(\frac{x^2-n}{m}\right)} = \frac{a^2}{b}$ [x]

21. $\frac{M}{N} + E = \frac{P}{N}$ [N]

22. $\frac{Q}{P-x} = R$ [x]

23. $\sqrt{(z-ax)} = t$ [a]

24. $e + \sqrt{(x+f)} = g$ [x]

25. $\frac{m(ny - e^2)}{p} + n = 5n$ [y]

5.3 Variation

Direct variation

There are several ways of expressing a relationship between two quantities x and y . Here are some examples.

- x varies as y
- x varies directly as y
- x is proportional to y

These three all mean the same and they are written in symbols as follows.

$$x \propto y$$

The ' \propto ' sign can always be replaced by '=' where k is a constant:

$$x = ky$$

Suppose $x = 3$ when $y = 12$;

$$\text{then } 3 = k \times 12$$

$$\text{and } k = \frac{1}{4}$$

We can then write $x = \frac{1}{4}y$, and this allows us to find the value of x for any value of y and *vice versa*.

Example 1

y varies as z , and $y = 2$ when $z = 5$; find

- (a) the value of y when $z = 6$
- (b) the value of z when $y = 5$

Because $y \propto z$, then $y = kz$ where k is a constant.

$$y = 2 \text{ when } z = 5$$

$$2 = k \times 5$$

$$k = \frac{2}{5}$$

$$\text{So } y = \frac{2}{5}z$$

$$\text{(a) When } z = 6, y = \frac{2}{5} \times 6 = 2\frac{2}{5}$$

$$\text{(b) When } y = 5, 5 = \frac{2}{5}z$$

$$z = \frac{25}{2} = 12\frac{1}{2}$$

Example 2

The value V of a diamond is proportional to the square of its weight W .

If a diamond weighing 10 grams is worth \$200, find:

- (a) the value of a diamond weighing 30 grams
- (b) the weight of a diamond worth \$5000.

$$V \propto W^2$$

or $V = kW^2$ where k is a constant.

$$V = 200 \text{ when } W = 10$$

$$\therefore 200 = k \times 10^2$$

$$k = 2$$

$$\text{So } V = 2W^2$$

(a) When $W = 30$,

$$V = 2 \times 30^2 = 2 \times 900$$

$$V = \text{£}1800$$

So a diamond of weight 30 grams is worth \$1800.

(b) When $V = 5000$,

$$5000 = 2 \times W^2$$

$$W^2 = \frac{5000}{2} = 2500$$

$$W = \sqrt{2500} = 50$$

So a diamond of value \$5000 weighs 50 grams.

Exercise 10

1. Rewrite the statement connecting each pair of variables using a constant k instead of ' \propto '.

(a) $S \propto e$

(b) $v \propto t$

(c) $x \propto z^2$

(d) $y \propto \sqrt{x}$

(e) $T \propto \sqrt{L}$

(f) $C \propto r$

(g) $A \propto r^2$

(h) $V \propto r^3$

2. y varies as t . If $y = 6$ when $t = 4$, calculate:

(a) the value of y , when $t = 6$

(b) the value of t , when $y = 4$.

3. z is proportional to m . If $z = 20$ when $m = 4$, calculate:

(a) the value of z , when $m = 7$

(b) the value of m , when $z = 55$.

4. A varies directly as r^2 . If $A = 12$, when $r = 2$, calculate:

(a) the value of A , when $r = 5$

(b) the value of r , when $A = 48$.

5. Given that $z \propto x$, copy and complete the table.

x	1	3		$5\frac{1}{2}$
z	4		16	

6. Given that $V \propto r^3$, copy and complete the table.

r	1	2		$1\frac{1}{2}$
V	4		256	

7. Given that $w \propto \sqrt{h}$, copy and complete the table.

h	4	9		$2\frac{1}{4}$
w	6		15	

8. s is proportional to $(v - 1)^2$. If $s = 8$, when $v = 3$, calculate:

(a) the value of s , when $v = 4$

(b) the value of v , when $s = 2$.

9. m varies as $(d + 3)$. If $m = 28$ when $d = 1$, calculate:
(a) the value of m , when $d = 3$
(b) the value of d , when $m = 49$.
10. The pressure of the water P at any point below the surface of the sea varies as the depth of the point below the surface d . If the pressure is 200 newtons/cm² at a depth of 3 m, calculate the pressure at a depth of 5 m.
11. The distance d through which a stone falls from rest is proportional to the square of the time taken t . If the stone falls 45 m in 3 seconds, how far will it fall in 6 seconds?
How long will it take to fall 20 m?
12. The energy E stored in an elastic band varies as the square of the extension x . When the elastic is extended by 3 cm, the energy stored is 243 joules. What is the energy stored when the extension is 5 cm?
What is the extension when the stored energy is 36 joules?
13. In the first few days of its life, the length of an earthworm l is thought to be proportional to the square root of the number of hours n which have elapsed since its birth. If a worm is 2 cm long after 1 hour, how long will it be after 4 hours?
How long will it take to grow to a length of 14 cm?
14. It is well known that the number of golden eggs which a goose lays in a week varies as the cube root of the average number of hours of sleep she has. When she has 8 hours sleep, she lays 4 golden eggs.
How long does she sleep when she lays 5 golden eggs?
15. The resistance to motion of a car is proportional to the square of the speed of the car. If the resistance is 4000 newtons at a speed of 20 m/s, what is the resistance at a speed of 30 m/s?
At what speed is the resistance 6250 newtons?
16. A road research organisation recently claimed that the damage to road surfaces was proportional to the fourth power of the axle load. The axle load of a 44 ton HGV is about 15 times that of a car.
Calculate the ratio of the damage to road surfaces made by a 44-ton HGV and a car.

Inverse variation

There are several ways of expressing an inverse relationship between two variables,

- x varies inversely as y
- x is inversely proportional to y .

We write $x \propto \frac{1}{y}$ for both statements and proceed using the method outlined in the previous section.

Example

z is inversely proportional to t^2 and $z = 4$ when $t = 1$. Calculate:

- (a) z when $t = 2$
 (b) t when $z = 16$.

We have $z \propto \frac{1}{t^2}$

or $z = k \times \frac{1}{t^2}$ (k is a constant)

$z = 4$ when $t = 1$,

$$\therefore 4 = k \left(\frac{1}{1^2} \right)$$

so $k = 4$

$$\therefore z = 4 \times \frac{1}{t^2}$$

(a) when $t = 2$, $z = 4 \times \frac{1}{2^2} = 1$

(b) when $z = 16$, $16 = 4 \times \frac{1}{t^2}$

$$16t^2 = 4$$

$$t^2 = \frac{1}{4}$$

$$t = \pm \frac{1}{2}$$

Exercise 11

1. Rewrite the statements connecting the variables using a constant of variation, k .

(a) $x \propto \frac{1}{y}$

(b) $s \propto \frac{1}{t^2}$

(c) $t \propto \frac{1}{\sqrt{q}}$

(d) m varies inversely as w

(e) z is inversely proportional to t^2 .

2. b varies inversely as e . If $b = 6$ when $e = 2$, calculate:

- (a) the value of b when $e = 12$
 (b) the value of e when $b = 3$.

3. q varies inversely as r . If $q = 5$ when $r = 2$, calculate:

- (a) the value of q when $r = 4$
 (b) the value of r when $q = 20$.

4. x is inversely proportional to y^2 . If $x = 4$ when $y = 3$, calculate:

- (a) the value of x when $y = 1$
 (b) the value of y when $x = 2\frac{1}{4}$.

5. R varies inversely as v^2 . If $R = 120$ when $v = 1$, calculate:

- (a) the value of R when $v = 10$
 (b) the value of v when $R = 30$.

6. T is inversely proportional to x^2 . If $T = 36$ when $x = 2$, calculate:

- (a) the value of T when $x = 3$
 (b) the value of x when $T = 1.44$.

7. p is inversely proportional to \sqrt{y} . If $p = 1.2$ when $y = 100$, calculate:

- (a) the value of p when $y = 4$
 (b) the value of y when $p = 3$.

8. y varies inversely as z . If $y = \frac{1}{8}$ when $z = 4$, calculate:

- (a) the value of y when $z = 1$
 (b) the value of z when $y = 10$.

9. Given that $z \propto \frac{1}{y}$, copy and complete the table:

y	2	4		$\frac{1}{4}$
z	8		16	

10. Given that $v \propto \frac{1}{t^2}$, copy and complete the table:

t	2	5		10
v	25		$\frac{1}{4}$	

11. Given that $r \propto \frac{1}{\sqrt{x}}$, copy and complete the table:

x	1	4		
r	12		$\frac{3}{4}$	2

12. e varies inversely as $(y - 2)$. If $e = 12$ when $y = 4$, find

- (a) e when $y = 6$ (b) y when $e = \frac{1}{2}$.

13. M is inversely proportional to the square of l .

If $M = 9$ when $l = 2$, find:

- (a) M when $l = 10$ (b) l when $M = 1$.

14. Given $z = \frac{k}{x^n}$, find k and n , then copy and complete the table.

x	1	2	4	
z	100	$12\frac{1}{2}$		$\frac{1}{10}$

15. Given $y = \frac{k}{\sqrt[3]{v}}$, find k and n , then copy and complete the table.

v	1	4	36	
y	12	6		$\frac{3}{25}$

16. The volume V of a given mass of gas varies inversely as the pressure P . When $V = 2 \text{ m}^3$, $P = 500 \text{ N/m}^2$. Find the volume when the pressure is 400 N/m^2 . Find the pressure when the volume is 5 m^3 .
17. The number of hours N required to dig a certain hole is inversely proportional to the number of men available x . When 6 men are digging, the hole takes 4 hours. Find the time taken when 8 men are available. If it takes $\frac{1}{2}$ hour to dig the hole, how many men are there?
18. The life expectancy L of a rat varies inversely as the square of the density d of poison distributed around his home. When the density of poison is 1 g/m^2 the life expectancy is 50 days. How long will he survive if the density of poison is:
 (a) 5 g/m^2 ? (b) $\frac{1}{2} \text{ g/m}^2$?
19. The force of attraction F between two magnets varies inversely as the square of the distance d between them. When the magnets are 2 cm apart, the force of attraction is 18 newtons. How far apart are they if the attractive force is 2 newtons?

5.4 Indices

Rules of indices

1. $a^n \times a^m = a^{n+m}$ e.g. $7^2 \times 7^4 = 7^6$
 2. $a^n \div a^m = a^{n-m}$ e.g. $6^6 \div 6^2 = 6^4$
 3. $(a^n)^m = a^{nm}$ e.g. $(3^2)^5 = 3^{10}$
- Also, $a^{-n} = \frac{1}{a^n}$ e.g. $5^{-2} = \frac{1}{5^2}$
 $a^{\frac{1}{n}}$ means 'the n th root of a ' e.g. $9^{\frac{1}{2}} = \sqrt[2]{9}$
 $a^{\frac{m}{n}}$ means 'the n th root of a raised to the power m '
 e.g. $4^{\frac{3}{2}} = (\sqrt{4})^3 = 8$

Example

Simplify:

- (a) $x^7 \times x^{13}$ (b) $x^3 \div x^7$
 (c) $(x^4)^3$ (d) $(3x^2)^3$
 (e) $(2x^{-1})^2 \div x^{-5}$ (f) $3y^2 \times 4y^3$
- (a) $x^7 \times x^{13} = x^{7+13} = x^{20}$
 (b) $x^3 \div x^7 = x^{3-7} = x^{-4} = \frac{1}{x^4}$
 (c) $(x^4)^3 = x^{12}$
 (d) $(3x^2)^3 = 3^3 \times (x^2)^3 = 27x^6$
 (e) $(2x^{-1})^2 \div x^{-5} = 4x^{-2} \div x^{-5}$
 $= 4x^{(-2)-(-5)}$
 $= 4x^3$
 (f) $3y^2 \times 4y^3 = 12y^5$

Exercise 12

Express in index form:

1. $3 \times 3 \times 3 \times 3$

2. $4 \times 4 \times 5 \times 5 \times 5$

3. $3 \times 7 \times 7 \times 7$

4. $2 \times 2 \times 2 \times 7$

5. $\frac{1}{10 \times 10 \times 10}$

6. $\frac{1}{2 \times 2 \times 3 \times 3 \times 3}$

7. $\sqrt{15}$

8. $\sqrt[3]{3}$

9. $\sqrt[3]{10}$

10. $(\sqrt{5})^3$

Simplify:

11. $x^3 \times x^4$

12. $y^6 \times y^7$

13. $z^7 \div z^3$

14. $z^{50} \times z^{50}$

15. $m^3 \div m^2$

16. $e^{-3} \times e^{-2}$

17. $y^{-2} \times y^4$

18. $w^4 \div w^{-2}$

19. $y^{\frac{1}{2}} \times y^{\frac{1}{2}}$

20. $(x^2)^5$

21. $x^{-2} \div x^{-2}$

22. $w^{-3} \times w^{-2}$

23. $w^{-7} \times w^2$

24. $x^3 \div x^{-4}$

25. $(a^2)^4$

26. $(k^{\frac{1}{2}})^6$

27. $e^{-4} \times e^4$

28. $x^{-1} \times x^{30}$

29. $(y^4)^{\frac{1}{2}}$

30. $(x^{-3})^{-2}$

31. $z^2 \div z^{-2}$

32. $t^{-3} \div t$

33. $(2x^3)^2$

34. $(4y^5)^2$

35. $2x^2 \times 3x^2$

36. $5y^3 \times 2y^2$

37. $5a^3 \times 3a$

38. $(2a)^3$

39. $3x^3 \div x^3$

40. $8y^3 \div 2y$

41. $10y^2 \div 4y$

42. $8a \times 4a^3$

43. $(2x)^2 \times (3x)^3$

44. $4z^4 \times z^{-7}$

45. $6x^{-2} \div 3x^2$

46. $5y^3 \div 2y^{-2}$

47. $(x^2)^{\frac{1}{2}} \div (x^{\frac{1}{3}})^3$

48. $7w^{-2} \times 3w^{-1}$

49. $(2n)^4 \div 8n^0$

50. $4x^{\frac{3}{2}} \div 2x^{\frac{1}{2}}$

Example

Evaluate:

(a) $9^{\frac{1}{2}}$

(b) 5^{-1}

(c) $4^{-\frac{1}{2}}$

(d) $25^{\frac{3}{2}}$

(e) $(5^{\frac{1}{2}})^3 \times 5^{\frac{1}{2}}$

(f) 7^0

(a) $9^{\frac{1}{2}} = \sqrt{9} = 3$

(b) $5^{-1} = \frac{1}{5}$

(c) $4^{-\frac{1}{2}} = \frac{1}{4^{\frac{1}{2}}} = \frac{1}{\sqrt{4}} = \frac{1}{2}$

(d) $25^{\frac{3}{2}} = (\sqrt{25})^3 = 5^3 = 125$

(e) $(5^{\frac{1}{2}})^3 \times 5^{\frac{1}{2}} = 5^{\frac{3}{2}} \times 5^{\frac{1}{2}} = 5^2 = 25$

(f) $7^0 = 1 \left[\text{consider } \frac{7^3}{7^3} = 7^{3-3} = 7^0 = 1 \right]$

Remember: $a^0 = 1$ for any non-zero value of a .**Exercise 13**

Evaluate the following:

1. $3^2 \times 3$

2. 100^0

3. 3^{-2}

4. $(5^{-1})^{-2}$

5. $4^{\frac{1}{2}}$

6. $16^{\frac{1}{2}}$

7. $81^{\frac{1}{2}}$

8. $8^{\frac{1}{3}}$

9. $9^{\frac{3}{2}}$

10. $27^{\frac{1}{3}}$

11. $9^{-\frac{1}{2}}$

12. $8^{-\frac{1}{3}}$

13. $1^{\frac{5}{2}}$

14. $25^{-\frac{1}{2}}$

15. $1000^{\frac{1}{3}}$

16. $2^{-2} \times 2^5$

17. $2^4 \div 2^{-1}$

18. $8^{\frac{2}{3}}$

19. $27^{-\frac{2}{3}}$

20. $4^{-\frac{3}{2}}$

- | | | | |
|--|--|--|--|
| 21. $36^{\frac{1}{2}} \times 27^{\frac{1}{3}}$ | 22. $10\,000^{\frac{1}{4}}$ | 23. $100^{\frac{3}{2}}$ | 24. $(100^{\frac{1}{2}})^{-3}$ |
| 25. $(9^{\frac{1}{2}})^{-2}$ | 26. $(-16 \cdot 371)^0$ | 27. $81^{\frac{1}{4}} \div 16^{\frac{1}{4}}$ | 28. $(5^{-4})^{\frac{1}{2}}$ |
| 29. $1000^{-\frac{1}{3}}$ | 30. $(4^{-\frac{1}{2}})^2$ | 31. $8^{-\frac{2}{3}}$ | 32. $100^{\frac{2}{3}}$ |
| 33. $1^{\frac{4}{3}}$ | 34. 2^{-5} | 35. $(0 \cdot 01)^{\frac{1}{2}}$ | 36. $(0 \cdot 04)^{\frac{1}{2}}$ |
| 37. $(2 \cdot 25)^{\frac{1}{2}}$ | 38. $(7 \cdot 63)^0$ | 39. $3^5 \times 3^{-3}$ | 40. $(3\frac{3}{8})^{\frac{1}{2}}$ |
| 41. $(11\frac{1}{9})^{-\frac{1}{2}}$ | 42. $(\frac{1}{8})^{-2}$ | 43. $(\frac{1}{1000})^{\frac{2}{3}}$ | 44. $(\frac{9}{25})^{-\frac{1}{2}}$ |
| 45. $(10^{-6})^{\frac{1}{3}}$ | 46. $7^2 \div (7^{\frac{1}{2}})^4$ | 47. $(0 \cdot 0001)^{-\frac{1}{2}}$ | 48. $\frac{9^{\frac{1}{2}}}{4^{-\frac{1}{2}}}$ |
| 49. $\frac{25^{\frac{3}{2}} \times 4^{\frac{1}{2}}}{9^{-\frac{1}{2}}}$ | 50. $(-\frac{1}{7})^2 \div (-\frac{1}{7})^3$ | | |

Example

Simplify:

(a) $(2a)^3 \div (9a^2)^{\frac{1}{2}}$ (b) $(3ac^2)^3 \times 2a^{-2}$ (c) $(2x)^2 \div 2x^2$

(a) $(2a)^3 \div (9a^2)^{\frac{1}{2}} = 8a^3 \div 3a$
 $= \frac{8}{3}a^2$

(b) $(3ac^2)^3 \times 2a^{-2} = 27a^3c^6 \times 2a^{-2}$
 $= 54ac^6$

(c) $(2x)^2 \div 2x^2 = 4x^2 \div 2x^2$
 $= 2$

Exercise 14

Rewrite without brackets:

- | | | | |
|----------------------------|----------------------------|----------------------------|---------------------|
| 1. $(5x^2)^2$ | 2. $(7y^3)^2$ | 3. $(10ab)^2$ | 4. $(2xy^2)^2$ |
| 5. $(4x^2)^{\frac{1}{2}}$ | 6. $(9y)^{-1}$ | 7. $(x^{-2})^{-1}$ | 8. $(2x^{-2})^{-1}$ |
| 9. $(5x^2y)^0$ | 10. $(\frac{1}{2}x)^{-1}$ | 11. $(3x)^2 \times (2x)^2$ | 12. $(5y)^2 \div y$ |
| 13. $(2x^{\frac{1}{2}})^4$ | 14. $(3y^{\frac{1}{3}})^3$ | 15. $(5x^0)^2$ | 16. $[(5x^0)^2]^2$ |
| 17. $(7y^0)^2$ | 18. $[(7y^0)^2]^2$ | 19. $(2x^2y)^3$ | 20. $(10xy^3)^2$ |

Simplify the following:

- | | | | |
|----------------------------------|--|-----------------------------|--|
| 21. $(3x^{-1})^2 \div 6x^{-3}$ | 22. $(4x)^{\frac{1}{2}} \div x^{\frac{3}{2}}$ | 23. $x^2y^2 \times xy^3$ | 24. $4xy \times 3x^2y$ |
| 25. $10x^{-1}y^3 \times xy$ | 26. $(3x)^2 \times (\frac{1}{9}x^2)^{\frac{1}{2}}$ | 27. $z^3yx \times x^2yz$ | 28. $(2x)^{-2} \times 4x^3$ |
| 29. $(3y)^{-1} \div (9y^2)^{-1}$ | 30. $(xy)^0 \times (9x)^{\frac{3}{2}}$ | 31. $(x^2y)(2xy)(5y^3)$ | 32. $(4x^{\frac{1}{2}}) \times (8x^{\frac{3}{2}})$ |
| 33. $5x^{-3} \div 2x^{-5}$ | 34. $[(3x^{-1})^{-2}]^{-1}$ | 35. $(2a)^{-2} \times 8a^4$ | 36. $(abc^2)^3$ |
37. Write in the form 2^p (e.g. $4 = 2^2$):
(a) 32 (b) 128 (c) 64 (d) 1
38. Write in the form 3^q :
(a) $\frac{1}{27}$ (b) $\frac{1}{81}$ (c) $\frac{1}{3}$ (d) $9 \times \frac{1}{81}$

Evaluate, with $x = 16$ and $y = 8$.

- | | | | |
|---|---|---|---|
| 39. $2x^{\frac{1}{2}} \times y^{\frac{1}{3}}$ | 40. $x^{\frac{1}{4}} \times y^{-1}$ | 41. $(y^2)^{\frac{1}{6}} \div (9x)^{\frac{1}{2}}$ | 42. $(x^2y^3)^0$ |
| 43. $x + y^{-1}$ | 44. $x^{-\frac{1}{2}} + y^{-1}$ | 45. $y^{\frac{1}{3}} \div x^{\frac{2}{3}}$ | 46. $(1000y)^{\frac{1}{3}} \times x^{-\frac{5}{2}}$ |
| 47. $(x^{\frac{1}{4}} + y^{-1}) \div x^{\frac{1}{4}}$ | 48. $x^{\frac{1}{2}} - y^{\frac{2}{3}}$ | 49. $(x^{\frac{3}{4}}y)^{-\frac{1}{3}}$ | 50. $(\frac{x}{y})^{-2}$ |

Solve the equations for x .

51. $2^x = 8$

52. $3^x = 81$

53. $5^x = \frac{1}{5}$

54. $10^x = \frac{1}{100}$

55. $3^{-x} = \frac{1}{27}$

56. $4^x = 64$

57. $6^{-x} = \frac{1}{6}$

58. $100\,000^x = 10$

59. $12^x = 1$

60. $10^x = 0.0001$

61. $2^x + 3^x = 13$

62. $(\frac{1}{2})^x = 32$

63. $5^{2x} = 25$

64. $1\,000\,000^{3x} = 10$

65. These two are more difficult. Use a calculator to find solutions correct to three significant figures.

(a) $x^x = 100$

(b) $x^x = 10\,000$

5.5 Inequalities

$x < 4$ means 'x is less than 4'

$y > 7$ means 'y is greater than 7'

$z \leq 10$ means 'z is less than or equal to 10'

$t \geq -3$ means 't is greater than or equal to -3'

Solving inequalities

We follow the same procedure used for solving equations except that when we multiply or divide by a *negative* number the inequality is *reversed*.

e.g. $4 > -2$

but multiplying by -2 ,

$$-8 < 4$$

Example

Solve the inequalities:

(a) $2x - 1 > 5$

$2x > 5 + 1$

$x > \frac{6}{2}$

$x > 3$

(b) $5 - 3x \leq 1$

$5 \leq 1 + 3x$

$5 - 1 \leq 3x$

$\frac{4}{3} \leq x$

Exercise 15

Introduce one of the symbols $<$, $>$ or $=$ between each pair of numbers.

1. $-2, 1$

2. $(-2)^2, 1$

3. $\frac{1}{4}, \frac{1}{5}$

4. $0.2, \frac{1}{5}$

5. $10^2, 2^{10}$

6. $\frac{1}{4}, 0.4$

7. $40\%, 0.4$

8. $(-1)^2, (-\frac{1}{2})^2$

9. $5^2, 2^5$

10. $3\frac{1}{3}, \sqrt{10}$

11. $\pi^2, 10$

12. $-\frac{1}{3}, -\frac{1}{2}$

13. $2^{-1}, 3^{-1}$

14. $50\%, \frac{1}{5}$

15. $1\%, 100^{-1}$

State whether the following are true or false:

- | | | |
|---------------------------|---------------------------------|-------------------------------------|
| 16. $0.7^2 > \frac{1}{2}$ | 17. $10^3 = 30$ | 18. $\frac{1}{8} > 12\%$ |
| 19. $(0.1)^3 = 0.0001$ | 20. $(-\frac{1}{5})^0 = -1$ | 21. $\frac{1}{5^2} > \frac{1}{2^5}$ |
| 22. $(0.2)^3 < (0.3)^2$ | 23. $\frac{6}{7} > \frac{7}{8}$ | 24. $0.1^2 > 0.1$ |

Solve the following inequalities:

- | | | | |
|------------------|-----------------------|---------------------------|---------------------|
| 25. $x - 3 > 10$ | 26. $x + 1 < 0$ | 27. $5 > x - 7$ | 28. $2x + 1 \leq 6$ |
| 29. $3x - 4 > 5$ | 30. $10 \leq 2x - 6$ | 31. $5x < x + 1$ | 32. $2x \geq x - 3$ |
| 33. $4 + x < -4$ | 34. $3x + 1 < 2x + 5$ | 35. $2(x + 1) > x - 7$ | 36. $7 < 15 - x$ |
| 37. $9 > 12 - x$ | 38. $4 - 2x \leq 2$ | 39. $3(x - 1) < 2(1 - x)$ | 40. $7 - 3x < 0$ |

The number line

The inequality $x < 4$ is represented on the number line as

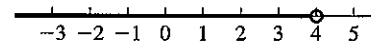

$x \geq -2$ is shown as

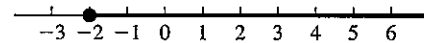

In the first case, 4 is *not* included so we have \circ .

In the second case, -2 is included so we have \bullet .

$-1 \leq x < 3$ is shown as

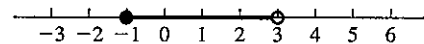

Exercise 16

For questions 1 to 25, solve each inequality and show the result on a number line.

- | | | |
|-----------------------------|---------------------------------|-----------------------------|
| 1. $2x + 1 > 11$ | 2. $3x - 4 \leq 5$ | 3. $2 < x - 4$ |
| 4. $6 \geq 10 - x$ | 5. $8 < 9 - x$ | 6. $8x - 1 < 5x - 10$ |
| 7. $2x > 0$ | 8. $1 < 3x - 11$ | 9. $4 - x > 6 - 2x$ |
| 10. $\frac{x}{3} < -1$ | 11. $1 < x < 4$ | 12. $-2 \leq x \leq 5$ |
| 13. $1 \leq x < 6$ | 14. $0 \leq 2x < 10$ | 15. $-3 \leq 3x \leq 21$ |
| 16. $1 < 5x < 10$ | 17. $\frac{x}{4} > 20$ | 18. $3x - 1 > x + 19$ |
| 19. $7(x + 2) < 3x + 4$ | 20. $1 < 2x + 1 < 9$ | 21. $10 \leq 2x \leq x + 9$ |
| 22. $x < 3x + 2 < 2x + 6$ | 23. $10 \leq 2x - 1 \leq x + 5$ | 24. $x < 3x - 1 < 2x + 7$ |
| 25. $x - 10 < 2(x - 1) < x$ | | |

(Hint: in questions 20 to 25, solve the two inequalities separately.)

For questions 26 to 35, find the solutions, subject to the given condition.

26. $3a + 1 < 20$; a is a positive integer
 27. $b - 1 \geq 6$; b is a prime number less than 20
 28. $2e - 3 < 21$; e is a positive even number

29. $1 < z < 50$; z is a square number
 30. $0 < 3x < 40$; x is divisible by 5
 31. $2x > -10$; x is a negative integer
 32. $x + 1 < 2x < x + 13$; x is an integer
 33. $x^2 < 100$; x is a positive square number
 34. $0 \leq 2z - 3 \leq z + 8$; z is a prime number
 35. $\frac{a}{2} + 10 > a$; a is a positive even number
 36. State the smallest integer n for which $4n > 19$.
 37. Find an integer value of x such that $2x - 7 < 8 < 3x - 11$.
 38. Find an integer value of y such that $3y - 4 < 12 < 4y - 5$.
 39. Find any value of z such that $9 < z + 5 < 10$.
 40. Find any value of p such that $9 < 2p + 1 < 11$.
 41. Find a simple fraction q such that $\frac{4}{9} < q < \frac{5}{9}$.
 42. Find an integer value of a such that $a - 3 \leq 11 \leq 2a + 10$.
 43. State the largest prime number z for which $3z < 66$.
 44. Find a simple fraction r such that $\frac{1}{3} < r < \frac{2}{3}$.
 45. Find the largest prime number p such that $p^2 < 400$.
 46. Illustrate on a number line the solution set of each pair of simultaneous inequalities:
 (a) $x < 6$; $-3 \leq x \leq 8$ (b) $x > -2$; $-4 < x < 2$
 (c) $2x + 1 \leq 5$; $-12 \leq 3x - 3$ (d) $3x - 2 < 19$; $2x \geq -6$
 47. Find the integer n such that $n < \sqrt{300} < n + 1$.

Graphical display

It is useful to represent inequalities on a graph, particularly where two variables are involved.

Drawing accurate graphs is explained in Unit 7.

Example

Draw a sketch graph and leave unshaded the area which represents the set of points that satisfy each of these inequalities:

(a) $x > 2$

(b) $1 \leq y \leq 5$

(c) $x + y \leq 8$

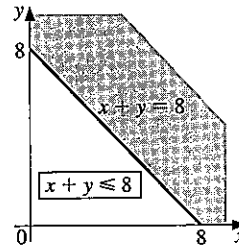
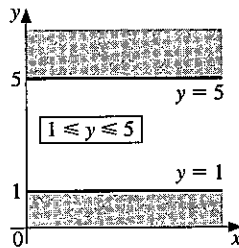
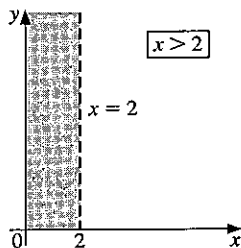

In each graph, the unwanted region is shaded so that the region representing the set of points is left clearly visible.

In (a), the line $x = 2$ is shown as a broken line to indicate that the points on the line are *not* included.

In (b) and (c), the lines $y = 1$, $y = 5$ and $x + y = 8$ are shown as solid lines because points on the line *are* included in the solution set.

An inequality can thus be regarded as a set of points, for example, the unshaded region in (c) may be described as

$$\{(x, y) : x + y \leq 8\}$$

i.e. the set of points (x, y) such that $x + y \leq 8$.

Exercise 17

In questions 1 to 9 describe the region left unshaded.

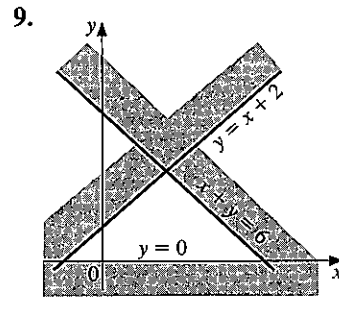
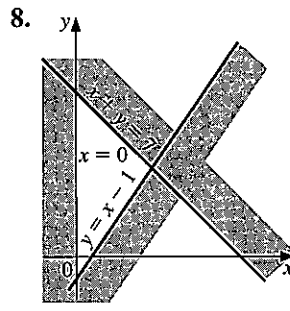
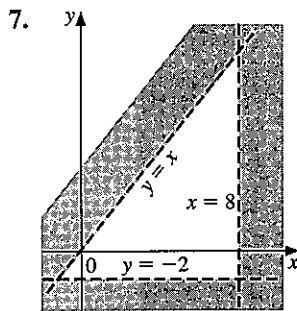
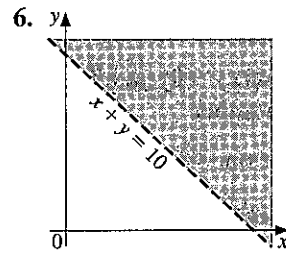
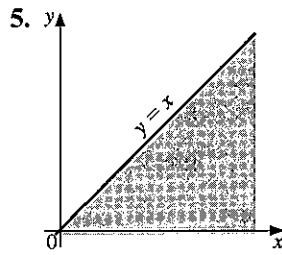
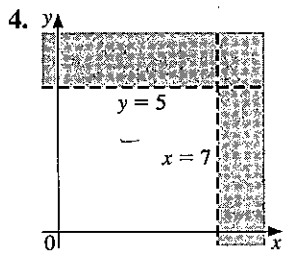
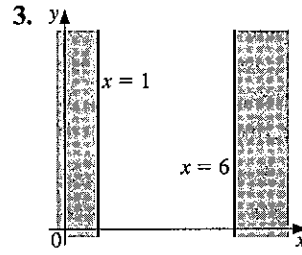
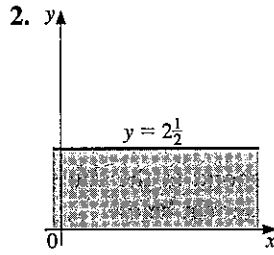
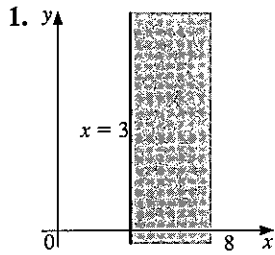

For questions 10 to 27, draw a sketch graph similar to those above and indicate the set of points which satisfy the inequalities by shading the unwanted regions.

- | | |
|---|--|
| 10. $2 \leq x \leq 7$ | 11. $0 \leq y \leq 3\frac{1}{2}$ |
| 12. $-2 < x < 2$ | 13. $x < 6$ and $y \leq 4$ |
| 14. $0 < x < 5$ and $y < 3$ | 15. $1 \leq x \leq 6$ and $2 \leq y \leq 8$ |
| 16. $-3 < x < 0$ and $-4 < y < 2$ | 17. $y \leq x$ |
| 18. $x + y < 5$ | 19. $y > x + 2$ and $y < 7$ |
| 20. $x \geq 0$ and $y \geq 0$ and $x + y \leq 7$ | 21. $x \geq 0$ and $x + y < 10$ and $y > x$ |
| 22. $8 \geq y \geq 0$ and $x + y > 3$ | 23. $x + 2y < 10$ and $x \geq 0$ and $y \geq 0$ |
| 24. $3x + 2y \leq 18$ and $x \geq 0$ and $y \geq 0$ | 25. $x \geq 0, y \geq x - 2, x + y \leq 10$ |
| 26. $3x + 5y \leq 30$ and $y > \frac{x}{2}$ | 27. $y \geq \frac{x}{2}, y \leq 2x$ and $x + y \leq 8$ |

5.6 Linear programming

In most linear programming problems, there are two stages:

1. to interpret the information given as a series of simultaneous inequalities and display them graphically.
2. to investigate some characteristic of the points in the unshaded solution set.

Example

A shopkeeper buys two types of dog food for his shop: Bruno at 40c a tin and Blaze at 60c a tin. He has \$15 available and decides to buy at least 30 tins altogether. He also decides that at least one third of the tins should be Blaze. He buys x tins of Bruno and y tins of Blaze.

- (a) Write down three inequalities which correspond to the above conditions.
- (b) Illustrate these inequalities on a graph, as shown below.
- (c) He makes a profit of 10c a tin on Bruno and a profit of 20c a tin on Blaze. Assuming he can sell all his stock, find how many tins of each type he should buy to maximise his profit and find that profit.

(a) Cost $40x + 60y \leq 1500$ $2x + 3y \leq 75$... [line A on graph]
 Total number $x + y \geq 30$... [line B on graph]

At least one third Blaze $\frac{y}{x} \geq \frac{1}{2}$ $2y \geq x$... [line C on graph]

- (b) The graph below shows these three equations.

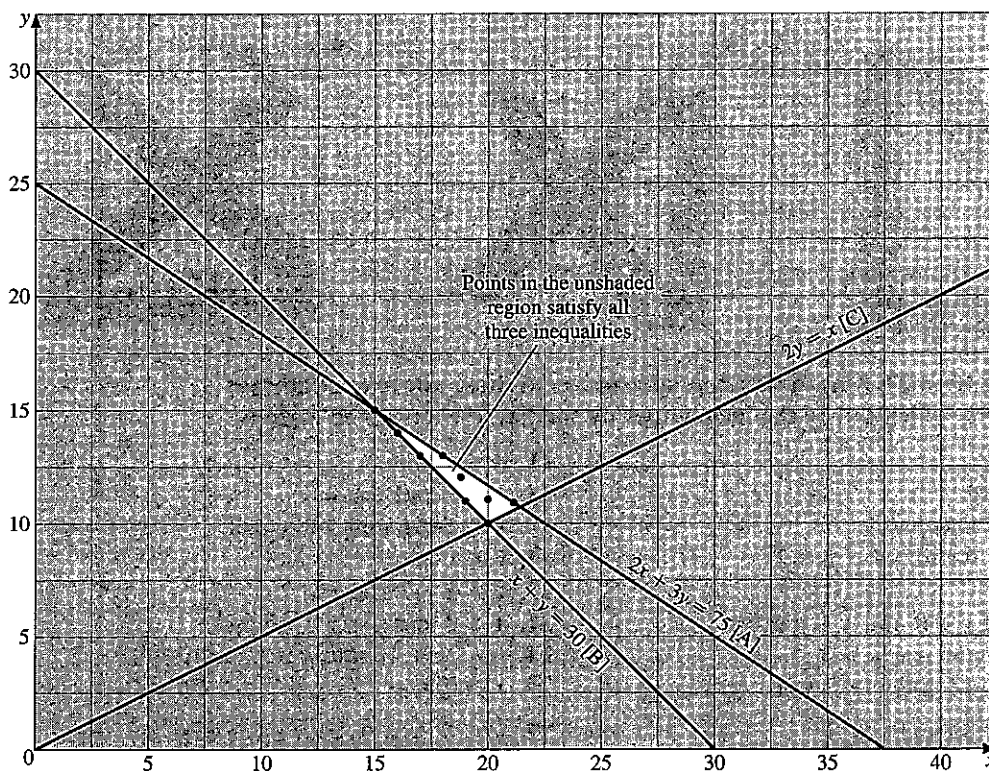

- (c) The table below shows the points on the graph in the unshaded region together with the corresponding figure for the profit.

The points marked * will clearly not provide a maximum profit.

x	15	16	17*	18	19	19*	20*	20*	21
y	15	14	13	13	12	11	11	10	11
profit	150	160		180	190				210
	+ 300	+ 280		+ 260	+ 240				+ 220
	450c	440c		440c	430c				430c

Conclusion: he should buy 15 tins of Bruno and 15 tins of Blaze. His maximised profit is then 450c.

Exercise 18

For questions 1 to 3, draw an accurate graph to represent the inequalities listed, using shading to show the unwanted regions.

1. $x + y \leq 11$; $y \geq 3$; $y \leq x$.

Find the point having whole number coordinates and satisfying these inequalities which gives:

- (a) the maximum value of $x + 4y$
 (b) the minimum value of $3x + y$

2. $3x + 2y > 24$; $x + y < 12$; $y < \frac{1}{2}x$; $y > 1$.

Find the point having whole number coordinates and satisfying these inequalities which gives:

- (a) the maximum value of $2x + 3y$
 (b) the minimum value of $x + y$

3. $3x + 2y \leq 60$; $x + 2y \leq 30$; $x \geq 10$; $y \geq 0$.

Find the point having whole number coordinates and satisfying these inequalities which gives:

- (a) the maximum value of $2x + y$
 (b) the maximum value of xy

4. Kojo is given \$1.20 to buy some peaches and apples. Peaches cost 20c each, apples 10c each. He is told to buy at least 6 individual fruits, but he must not buy more apples than peaches.

Let x be the number of peaches Kojo buys.

Let y be the number of apples Kojo buys.

- (a) Write down three inequalities which must be satisfied.
 (b) Draw a linear programming graph and use it to list the combinations of fruit that are open to Kojo.

5. Laura is told to buy some melons and oranges. Melons are 50c each and oranges 25c each, and she has \$2 to spend. She must not buy more than 2 melons and she must buy at least 4 oranges. She is also told to buy at least 6 fruits altogether.

Let x be the number of melons.

Let y be the number of oranges.

- (a) Write down four inequalities which must be satisfied.
(b) Draw a graph and use it to list the combinations of fruit that are open to Laura.
6. A chef is going to make some fruit cakes and sponge cakes. He has plenty of all ingredients except for flour and sugar. He has only 2000 g of flour and 1200 g of sugar.
A fruit cake uses 500 g of flour and 100 g of sugar.
A sponge cake uses 200 g of flour and 200 g of sugar.
He wishes to make *more than* 4 cakes altogether.
Let the number of fruit cakes be x .
Let the number of sponge cakes be y .
(a) Write down three inequalities which must be satisfied.
(b) Draw a graph and use it to list the possible combinations of fruit cakes and sponge cakes which he can make.
7. Kwame has a spare time job spraying cars and vans. Vans take 2 hours each and cars take 1 hour each. He has 14 hours available per week. He has an agreement with one firm to do 2 of their vans every week. Apart from that he has no fixed work.
Kwame's permission to use his back garden contains the clause that he must do at least twice as many cars as vans.
Let x be the number of vans sprayed each week.
Let y be the number of cars sprayed each week.
(a) Write down three inequalities which must be satisfied.
(b) Draw a graph and use it to list the possible combinations of vehicles which Kwame can spray each week.
8. The manager of a football team has \$100 to spend on buying new players. He can buy defenders at \$6 each or forwards at \$8 each. There must be at least 6 of each sort. To cover for injuries he must buy at least 13 players altogether. Let x represent the number of defenders he buys and y the number of forwards.
(a) In what ways can he buy players?
(b) If the wages are \$10 per week for each defender and \$20 per week for each forward, what is the combination of players which has the lowest wage bill?
9. A tennis-playing golfer has \$15 to spend on golf balls (x) costing \$1 each and tennis balls (y) costing 60c each. He must buy at least 16 altogether and he must buy *more* golf balls than tennis balls.
(a) What is the greatest number of balls he can buy?
(b) After using them, he can sell golf balls for 10c each and tennis balls for 20c each. What is his maximum possible income from sales?
10. A travel agent has to fly 1000 people and 35 000 kg of baggage from Hong Kong to Shanghai. Two types of aircraft are available: A which takes 100 people and 2000 kg of baggage, or B which takes 60 people and 3000 kg of baggage. He can use no more than 16 aircraft altogether. Write down three inequalities which must be satisfied if he uses x of A and y of B.

- (a) What is the smallest number of aircraft he could use?
 (b) If the hire charge for each aircraft A is \$10 000 and for each aircraft B is \$12 000, find the cheapest option available to him.
 (c) If the hire charges are altered so that each A costs \$10 000 and each B costs \$20 000, find the cheapest option now available to him.
11. A farmer has to transport 20 people and 32 sheep to a market. He can use either Fiats (x) which take 2 people and 1 sheep, or Rolls Royces (y) which take 2 people and 4 sheep. He must not use more than 15 cars altogether.
 (a) What is the lowest total numbers of cars he could use?
 (b) If it costs \$10 to hire each Fiat and \$30 for each Rolls Royce, what is the *cheapest* solution?
12. A shop owner wishes to buy up to 20 televisions for stock. He can buy either type A for \$150 each or type B for \$300 each. He has a total of \$4500 he can spend. He must have at least 6 of each type in stock. If he buys x of type A and y of type B, write down 4 inequalities which must be satisfied and represent the information on a graph.
 (a) If he makes a profit of \$40 on each of type A and \$100 on each of type B, how many of each should he buy for maximum profit?
 (b) If the profit is \$80 on each of type A and \$100 on each of type B, how many of each should he buy now?
13. A farmer needs to buy up to 25 cows for a new herd. He can buy either brown cows (x) at \$50 each or black cows (y) at \$80 each and he can spend a total of no more than \$1600. He must have at least 9 of each type.
 On selling the cows he makes a profit of \$50 on each brown cow and \$60 on each black cow. How many of each sort should he buy for maximum profit?
14. The manager of a car park allows 10m^2 of parking space for each car and 30m^2 for each lorry. The total space available is 300m^2 . He decides that the maximum number of vehicles at any time must not exceed 20 and he also insists that there must be at least as many cars as lorries. If the number of cars is x and the number of lorries is y , write down three inequalities which must be satisfied.
 (a) If the parking charge is \$1 for a car and \$5 for a lorry, find how many vehicles of each kind he should admit to maximise his income.
 (b) If the charges are changed to \$2 for a car and \$3 for a lorry, find how many of each kind he would be advised to admit.

Revision exercise 5A

1. Express the following as single fractions:

(a) $\frac{x}{4} + \frac{x}{5}$

(b) $\frac{1}{2x} + \frac{2}{3x}$

(c) $\frac{x+2}{2} + \frac{x-4}{3}$

(d) $\frac{7}{x-1} - \frac{2}{x+3}$

2. (a) Factorise $x^2 - 4$

(b) Simplify $\frac{3x-6}{x^2-4}$

3. Given that $s - 3t = rt$, express:

(a) s in terms of r and t

(b) r in terms of s and t

(c) t in terms of s and r .

4. (a) Given that $x - z = 5y$, express z in terms of x and y .

(b) Given that $mk + 3m = 11$, express m in terms of k .

(c) For the formula $T = C\sqrt{z}$, express z in terms of T and C .

5. It is given that $y = \frac{k}{x}$ and that $1 \leq x \leq 10$.

(a) If the smallest possible value of y is 5, find the value of the constant k .

(b) Find the largest possible value of y .

6. Given that y varies as x^2 and that $y = 36$ when $x = 3$, find:

(a) the value of y when $x = 2$

(b) the value of x when $y = 64$.

7. (a) Evaluate: (i) $9^{\frac{1}{2}}$ (ii) $8^{\frac{2}{3}}$ (iii) $16^{-\frac{1}{2}}$

(b) Find x , given that

(i) $3^x = 81$ (ii) $7^x = 1$.

8. List the integer values of x which satisfy.

(a) $2x - 1 < 20 < 3x - 5$

(b) $5 < 3x + 1 < 17$.

9. Given that $t = k\sqrt{(x+5)}$, express x in terms of t and k .

10. Given that $z = \frac{3y+2}{y-1}$, express y in terms of z .

11. Given that $y = \frac{k}{k+w}$

(a) Find the value of y when $k = \frac{1}{2}$ and $w = \frac{1}{3}$

(b) Express w in terms of y and k .

12. On a suitable sketch graph, identify clearly the region A defined by $x \geq 0$, $x + y \leq 8$ and $y \geq x$.

13. Without using a calculator, calculate the value of:

(a) $9^{-\frac{1}{2}} + (\frac{1}{8})^{\frac{1}{3}} + (-3)^0$

(b) $(1000)^{-\frac{1}{3}} - (0.1)^2$

14. It is given that $10^x = 3$ and $10^y = 7$. What is the value of 10^{x+y} ?

15. Make x the subject of the following formulae:

(a) $x + a = \frac{2x - 5}{a}$ (b) $cz + ax + b = 0$ (c) $a = \sqrt{\left(\frac{x+1}{x-1}\right)}$

16. Write the following as single fractions:

(a) $\frac{3}{x} + \frac{1}{2x}$ (b) $\frac{3}{a-2} + \frac{1}{a^2-4}$ (c) $\frac{3}{x(x+1)} - \frac{2}{x(x-2)}$

17. p varies jointly as the square of t and inversely as s . Given that $p = 5$ when $t = 1$ and $s = 2$, find a formula for p in terms of t and s .

18. A positive integer r is such that $pr^2 = 168$, where p lies between 3 and 5. List the possible values of r .

19. The shaded region A is formed by the lines $y = 2$, $y = 3x$ and $x + y = 6$. Write down the three inequalities which define A.

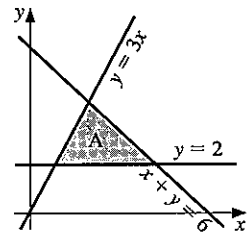

20. The shaded region B is formed by the lines $x = 0$, $y = x - 2$ and $x + y = 7$. Write down the four inequalities which define B.

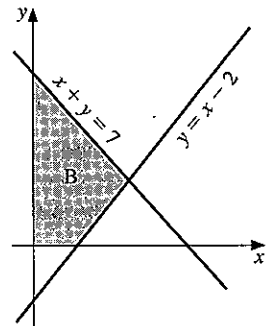

21. In the diagram, the solution set $-1 \leq x < 2$ is shown on a number line.



Illustrate, on similar diagrams, the solution set of the following pairs of simultaneous inequalities.

- (a) $x > 2$, $x \leq 7$ (b) $4 + x \geq 2$, $x + 4 < 10$
 (c) $2x + 1 \geq 3$, $x - 3 \leq 3$.

22. In a laboratory we start with 2 cells in a dish. The number of cells in the dish doubles every 30 minutes.

- (a) How many cells are in the dish after four hours?
 (b) After what time are there 2^{13} cells in the dish?
 (c) After $10\frac{1}{2}$ hours there are 2^{22} cells in the dish and an experimental fluid is added which eliminates half of the cells. How many cells are left?

Examination exercise 5B

1. (a) Find the value of $81^{\frac{1}{4}}$.(b) Simplify $\frac{3x^{-\frac{2}{3}}}{6x^{\frac{1}{3}}}$.

N 95 2

2. When $x = 27$, $y = \frac{1}{3}$ and $z = 2$, find the value of:(a) $8x^{\frac{1}{3}}$ (b) $\left(\frac{y}{z}\right)^{-2}$ (c) $(xy)^0$

J 96 2

3. A particle moving in a circle has an acceleration a which is inversely proportional to the radius r of the circle.When $r = 24$, $a = 2$.(a) Find an equation connecting a and r .(b) Calculate r when $a = 10$.

J 95 2

4. Find the values of p , q and r .(a) $\sqrt{x^{36}} = x^p$ (b) $10^q = 1$ (c) $r^{-\frac{1}{2}} = \frac{1}{4}$

J 98 2

5.

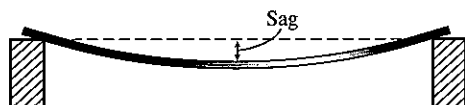

An engineer tests iron rods.

He measures the sag for different lengths of rod.

The results are as follows.

Length of rod (x metres)	0	1	2	3	4
Sag (y millimetres)	0	0.5	4	13.5	32

He knows that $y \propto x^n$, where n is a positive integer. Find the value of n .

N 96 2

6. The trapezium T is defined by four inequalities. One is $y \geq x$. Write down the other three inequalities.

J 98 2

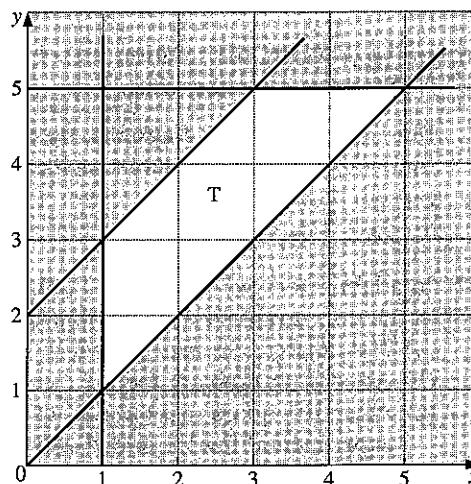

7. Arnie and Bernie are tailors. They make x jackets and y suits each week. Arnie does all the cutting, and Bernie does all the sewing. To make a jacket takes 5 hours of cutting and 4 hours of sewing. To make a suit takes 6 hours of cutting and 10 hours of sewing. Neither tailor works for more than 60 hours a week.

(a) For the sewing, show that:

$$2x + 5y \leq 30$$

- (b) Write down another inequality in x and y for the cutting.
 (c) They make at least 8 jackets each week. Write down another inequality.
 (d) (i) Draw axes from 0 to 16, using 1 cm to represent 1 unit on each axis.
 (ii) On your grid, show the information in parts (a), (b) and (c). Shade the unwanted regions.
 (e) The profit on a jacket is \$30 and on a suit is \$100. Calculate the maximum profit that Arnie and Bernie can make in a week.

N 96 4

8. A ferry has a deck area of 3600 m^2 for parking cars and trucks. Each car takes up 20 m^2 of deck area and each truck takes up 80 m^2 . On one trip, the ferry carries x cars and y trucks.

- (a) Show that this information leads to the inequality $x + 4y \leq 180$.
 (b) The charge for the trip is \$25 for a car and \$50 for a truck. The total amount of money taken is \$3000. Write down an equation to represent this information and simplify it.
 (c) The line $x + 4y = 180$ is drawn on this grid.
 (i) Draw, on a copy of the grid, the graph of your equation in part (b).
 (ii) Write down a possible number of cars and a possible number of trucks on the trip, which together satisfy both conditions.

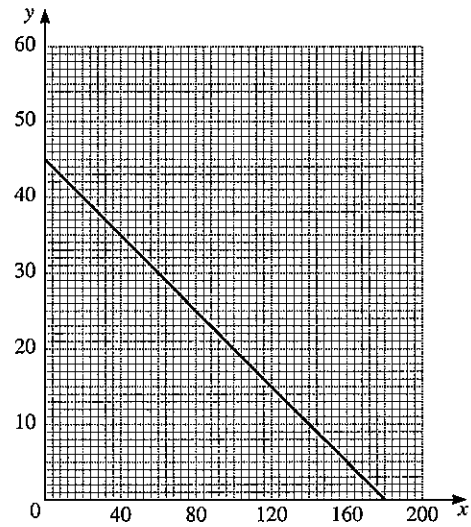

J 03 2

9. Solve the inequality

$$3 < 2x - 5 < 7$$

J 03 2

10. Work out as a single fraction

$$\frac{2}{x-3} - \frac{1}{x+4}$$

J 03 2

6 TRIGONOMETRY

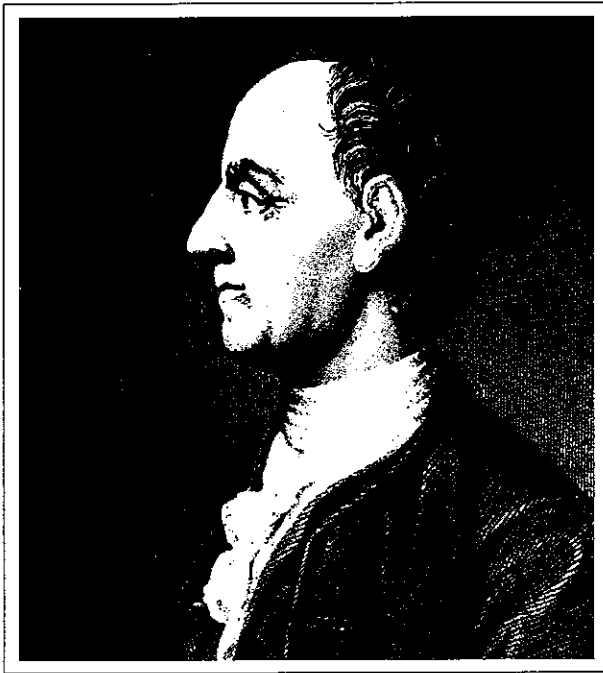

Leonard Euler (1707–1783) was born near Basel in Switzerland but moved to St Petersburg in Russia and later to Berlin. He had an amazing facility for figures but delighted in speculating in the realms of pure intellect. In trigonometry he introduced the use of small letters for the sides and capitals for the angles of a triangle. He also wrote r , R and s for the radius of the inscribed and of the circumscribed circles and the semi-perimeter, giving the beautiful formula $4rRs = abc$.

- 32** Apply the sine, cosine and tangent ratios for acute angles; extend sine and cosine values to angles between 90° and 180° ; interpret and use three-figure bearings; solve simple trigonometrical problems in three dimensions; solve problems using the sine and cosine rules

6.1 Right-angled triangles

The side opposite the right angle is called the hypotenuse (we will use H). It is the longest side.

The side opposite the marked angle of 35° is called the opposite (we will use O).

The other side is called the adjacent (we will use A).

Consider two triangles, one of which is an enlargement of the other.

It is clear that the ratio $\frac{O}{H}$ will be the same in both triangles.

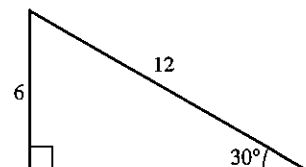
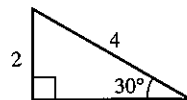
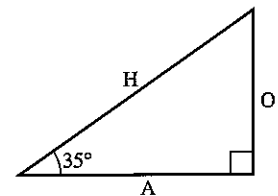

Sine, cosine and tangent

Three important functions are defined as follows:

$$\sin x = \frac{O}{H}$$

$$\cos x = \frac{A}{H}$$

$$\tan x = \frac{O}{A}$$

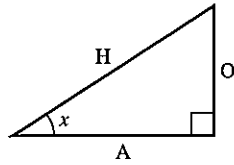

It is important to get the letters in the right order. Some people find a simple sentence helpful when the first letters of each word describe sine, cosine or tangent and Hypotenuse, Opposite and Adjacent. An example is:

Silly Old Harry Caught A Herring Trawling Off Afghanistan.

e.g. SOH: $\sin = \frac{O}{H}$

For any angle x the values for $\sin x$, $\cos x$ and $\tan x$ can be found using either a calculator or tables.

Exercise 1

1. Draw a circle of radius 10 cm and construct a tangent to touch the circle at T.

Draw OA, OB and OC where $\widehat{AOT} = 20^\circ$
 $\widehat{BOT} = 40^\circ$
 $\widehat{COT} = 50^\circ$

Measure the length AT and compare it with the value for $\tan 20^\circ$ given on a calculator or in tables. Repeat for BT, CT and for other angles of your own choice.

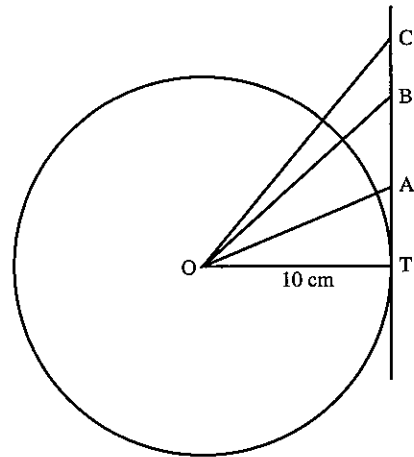

Finding the length of a side

Example 1

Find the side marked x .

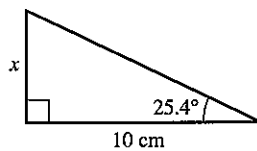

- (a) Label the sides of the triangle H, O, A (in brackets).

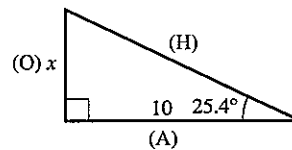

- (b) In this example, we know nothing about H so we need the function involving O and A.

$$\tan 25.4^\circ = \frac{O}{A} = \frac{x}{10}$$

- (c) Find $\tan 25.4^\circ$ from tables.

$$0.4748 = \frac{x}{10}$$

- (d) Solve for x .

$$x = 10 \times 0.4748 = 4.748$$

$$x = 4.75 \text{ cm (3 significant figures)}$$

Example 2

Find the side marked z .

- (a) Label H, O, A.

(b) $\sin 31.3^\circ = \frac{O}{H} = \frac{7.4}{z}$

- (c) Multiply by z .

$$z \times (\sin 31.3^\circ) = 7.4$$

$$z = \frac{7.4}{\sin 31.3}$$

- (d) On a calculator, press the keys as follows:

$$7.4 \div \sin 31.3 =$$

$$z = 14.2 \text{ cm (to 3 s.f.)}$$

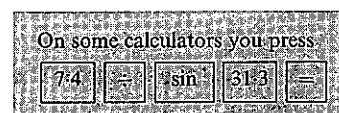
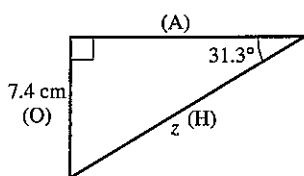

Exercise 2

In questions 1 to 22 all lengths are in centimetres. Find the sides marked with letters. Give your answers to three significant figures.

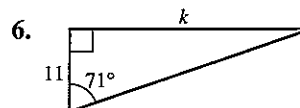
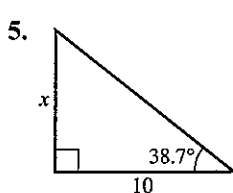
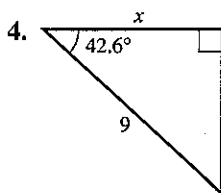
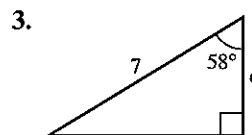
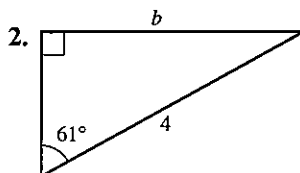
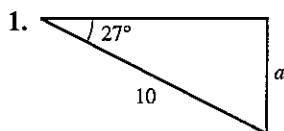

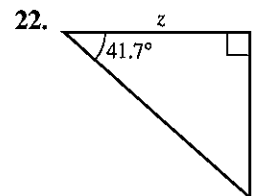
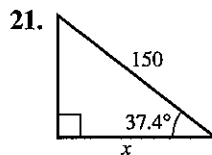
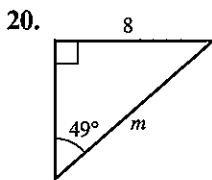
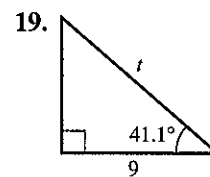
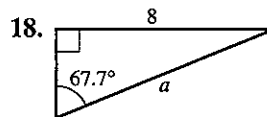
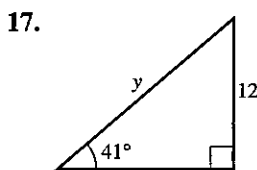
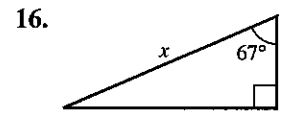
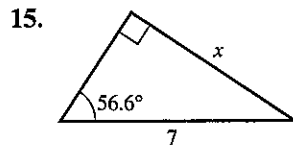
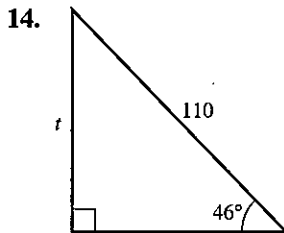
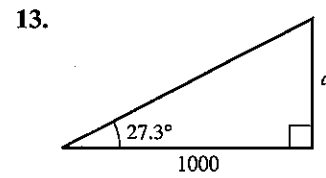
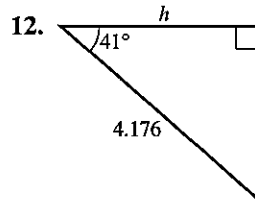
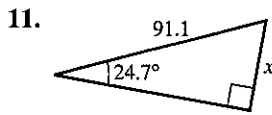
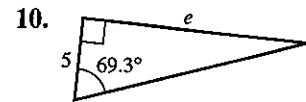
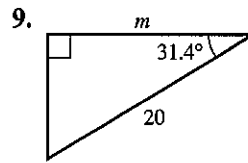
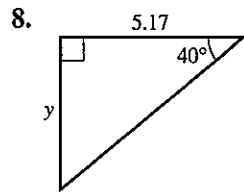
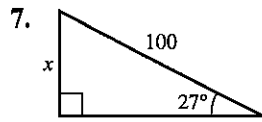

In questions 23 to 34, the triangle has a right angle at the middle letter.

23. In $\triangle ABC$, $\widehat{C} = 40^\circ$, $BC = 4$ cm. Find AB .
24. In $\triangle DEF$, $\widehat{F} = 35.3^\circ$, $DF = 7$ cm. Find ED .
25. In $\triangle GHI$, $\widehat{I} = 70^\circ$, $GI = 12$ m. Find HI .
26. In $\triangle JKL$, $\widehat{L} = 55^\circ$, $KL = 8.21$ m. Find JK .
27. In $\triangle MNO$, $\widehat{M} = 42.6^\circ$, $MO = 14$ cm. Find ON .
28. In $\triangle PQR$, $\widehat{P} = 28^\circ$, $PQ = 5.071$ m. Find PR .
29. In $\triangle STU$, $\widehat{S} = 39^\circ$, $TU = 6$ cm. Find SU .
30. In $\triangle VWX$, $\widehat{X} = 17^\circ$, $WV = 30.7$ m. Find WX .
31. In $\triangle ABC$, $\widehat{A} = 14.3^\circ$, $BC = 14$ m. Find AC .
32. In $\triangle KLM$, $\widehat{K} = 72.8^\circ$, $KL = 5.04$ cm. Find LM .
33. In $\triangle PQR$, $\widehat{R} = 31.7^\circ$, $QR = 0.81$ cm. Find PR .
34. In $\triangle XYZ$, $\widehat{X} = 81.07^\circ$, $YZ = 52.6$ m. Find XY .

Example

Find the length marked x .

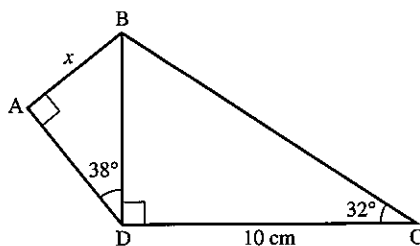

(a) Find BD from triangle BDC .

$$\tan 32^\circ = \frac{BD}{10}$$

$$\therefore BD = 10 \times \tan 32^\circ \quad \dots [1]$$

(b) Now find x from triangle ABD .

$$\sin 38^\circ = \frac{x}{BD}$$

$$\begin{aligned} \therefore x &= BD \times \sin 38^\circ \\ &= 10 \times \tan 32^\circ \times \sin 38^\circ \text{ (from [1])} \\ &= 3.85 \text{ cm (to 3 s.f.)} \end{aligned}$$

Notice that BD was *not* calculated in [1].

It is better to do all the multiplications at one time.

Exercise 3

In questions 1 to 10, find each side marked with a letter.

All lengths are in centimetres.

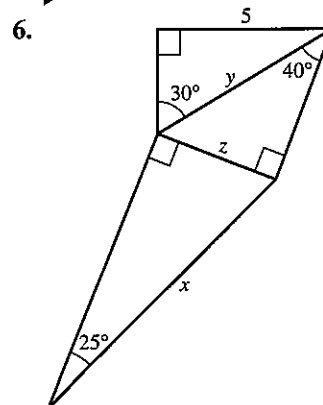
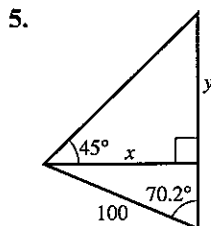
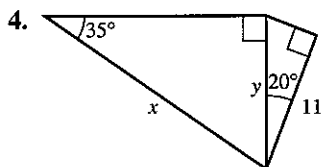
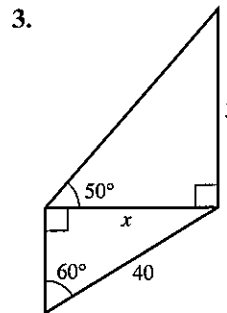
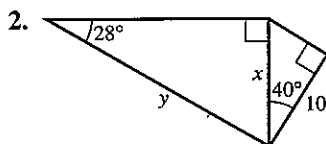
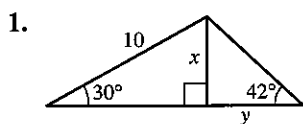

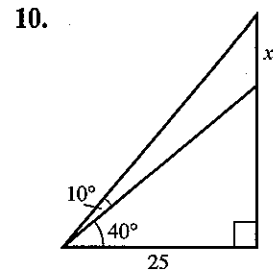
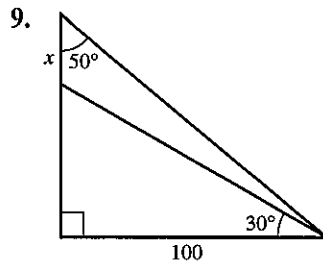
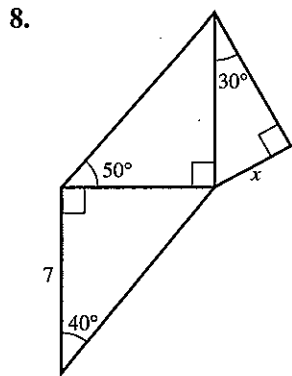
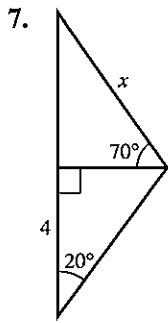

11. $\widehat{BAD} = \widehat{ACD} = 90^\circ$
 $\widehat{CAD} = 35^\circ$
 $\widehat{BDA} = 41^\circ$
 $AD = 20 \text{ cm}$
 Calculate:
 (a) AB
 (b) DC
 (c) BD

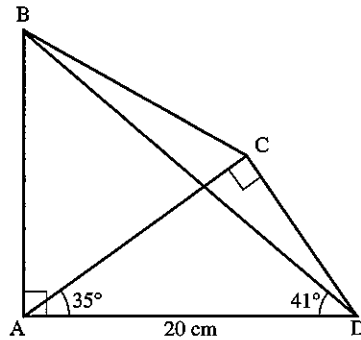

12. $\widehat{ABD} = \widehat{ADC} = 90^\circ$
 $\widehat{CAD} = 31^\circ$
 $\widehat{BDA} = 43^\circ$
 $AD = 10 \text{ cm}$
 Calculate:
 (a) AB
 (b) CD
 (c) DB

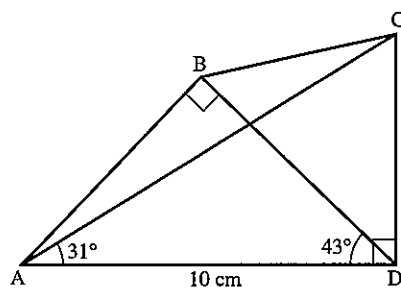

Finding an unknown angle

Example

Find the angle marked m .

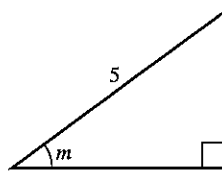

- (a) Label the sides of the triangle H, O, A in relation to angle m .

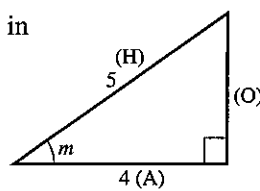

(b) In this example, we do not know 'O' so we need the cosine.

$$\cos m = \left(\frac{A}{H} \right) = \frac{4}{5}$$

(c) Change $\frac{4}{5}$ to a decimal: $\frac{4}{5} = 0.8$

(d) $\cos m = 0.8$

Find angle m from the cosine table: $m = 36.9^\circ$

Note: On a calculator, angles can be found as follows:

If $\cos m = \frac{4}{5}$

(a) Press

(b) Press and then

This will give the angle as 36.86989765° . We require the angle to 1 place of decimals so $m = 36.9^\circ$.

Exercise 4

In questions 1 to 15, find the angle marked with a letter. All lengths are in cm.

1.

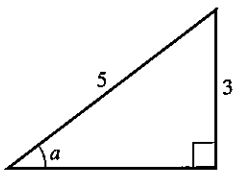

2.

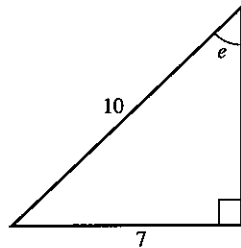

3.

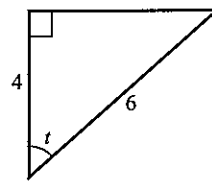

4.

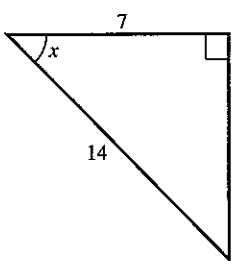

5.

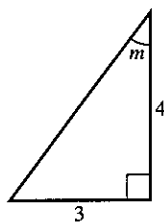

6.

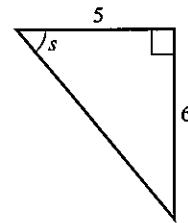

7.

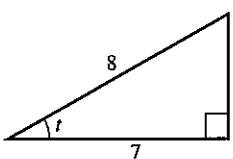

8.

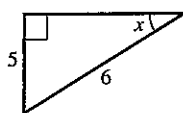

9.

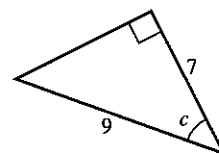

10.

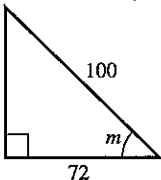

11.

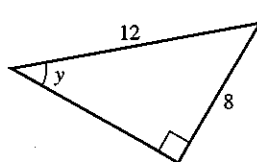

12.

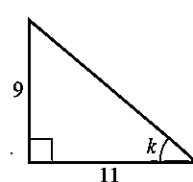

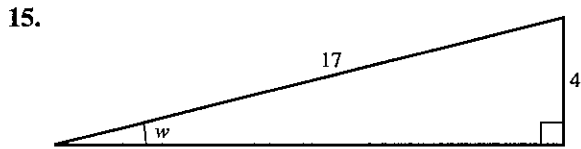
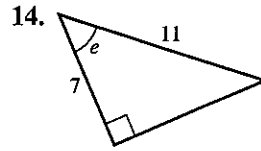
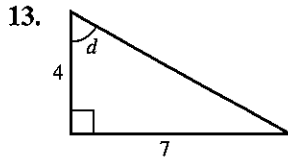

In questions 16 to 20, the triangle has a right angle at the middle letter.

16. In $\triangle ABC$, $BC = 4$, $AC = 7$. Find \hat{A} .

17. In $\triangle DEF$, $EF = 5$, $DF = 10$. Find \hat{F} .

18. In $\triangle GHI$, $GH = 9$, $HI = 10$. Find \hat{I} .

19. In $\triangle JKL$, $JL = 5$, $KL = 3$. Find \hat{J} .

20. In $\triangle MNO$, $MN = 4$, $NO = 5$. Find \hat{M} .

In questions 21 to 26, find the angle x .

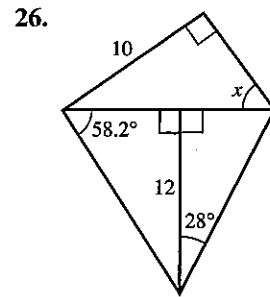
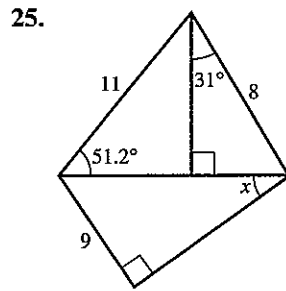
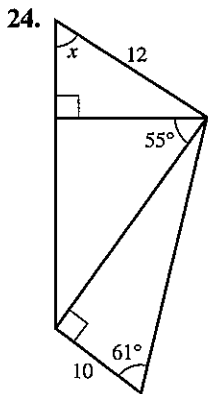
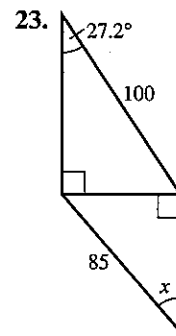
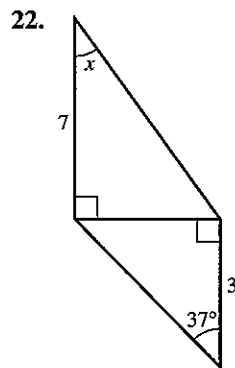
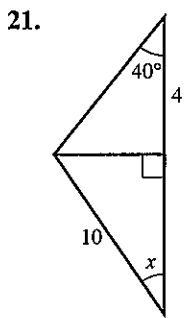

Bearings

A bearing is an angle measured clockwise from North.

It is given using three digits.

In the diagram:

the bearing of B from A is 052°

the bearing of A from B is 232° .

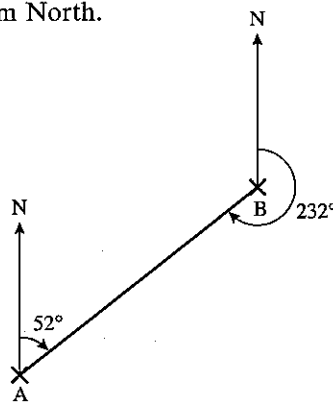

Example

A ship sails 22 km from A on a bearing of 042° , and a further 30 km on a bearing of 090° to arrive at B. What is the distance and bearing of B from A?

- (a) Draw a clear diagram and label extra points as shown.

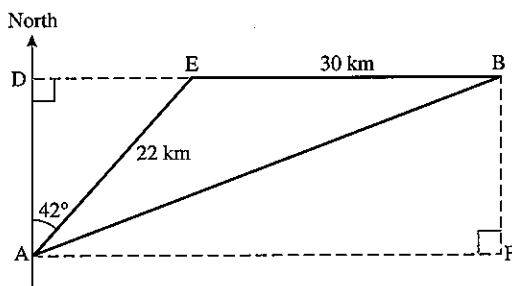

- (b) Find DE and AD.

$$(i) \sin 42^\circ = \frac{DE}{22}$$

$$\therefore DE = 22 \times \sin 42^\circ = 14.72 \text{ km}$$

$$(ii) \cos 42^\circ = \frac{AD}{22}$$

$$\therefore AD = 22 \times \cos 42^\circ = 16.35 \text{ km}$$

- (c) Using triangle ABF,
 $AB^2 = AF^2 + BF^2$ (Pythagoras' Theorem)

$$\text{and } AF = DE + EB$$

$$AF = 14.72 + 30 = 44.72 \text{ km}$$

$$\text{and } BF = AD = 16.35 \text{ km}$$

$$\therefore AB^2 = 44.72^2 + 16.35^2$$

$$= 2267.2$$

$$AB = 47.6 \text{ km (to 3 s.f.)}$$

- (d) The bearing of B from A is given by the angle DAB.
But $\widehat{DAB} = \widehat{ABF}$.

$$\begin{aligned}\tan \widehat{ABF} &= \frac{AF}{BF} = \frac{44.72}{16.35} \\ &= 2.7352\end{aligned}$$

$$\therefore \widehat{ABF} = 69.9^\circ$$

B is 47.6 km from A on a bearing of 069.9°.

Exercise 5

In this exercise, start by drawing a clear diagram.

- A ladder of length 6 m leans against a vertical wall so that the base of the ladder is 2 m from the wall. Calculate the angle between the ladder and the wall.
- A ladder of length 8 m rests against a wall so that the angle between the ladder and the wall is 31° . How far is the base of the ladder from the wall?
- A ship sails 35 km on a bearing of 042° .
(a) How far north has it travelled?
(b) How far east has it travelled?
- A ship sails 200 km on a bearing of 243.7° .
(a) How far south has it travelled?
(b) How far west has it travelled?
- Find TR if PR = 10 m and QT = 7 m.

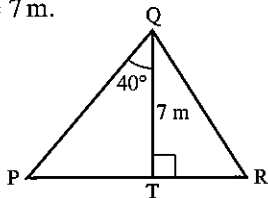

6. Find d .

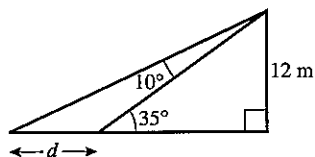

- An aircraft flies 400 km from a point O on a bearing of 025° and then 700 km on a bearing of 080° to arrive at B.
(a) How far north of O is B?
(b) How far east of O is B?
(c) Find the distance and bearing of B from O.
- An aircraft flies 500 km on a bearing of 100° and then 600 km on a bearing of 160° .
Find the distance and bearing of the finishing point from the starting point.

For questions 9 to 12, plot the points for each question on a sketch graph with x - and y -axes drawn to the same scale.

9. For the points $A(5, 0)$ and $B(7, 3)$, calculate the angle between AB and the x -axis.
10. For the points $C(0, 2)$ and $D(5, 9)$, calculate the angle between CD and the y -axis.
11. For the points $A(3, 0)$, $B(5, 2)$ and $C(7, -2)$, calculate the angle BAC .
12. For the points $P(2, 5)$, $Q(5, 1)$ and $R(0, -3)$, calculate the angle PQR .
13. From the top of a tower of height 75 m, a guard sees two prisoners, both due West of him. If the angles of depression of the two prisoners are 10° and 17° , calculate the distance between them.
14. An isosceles triangle has sides of length 8 cm, 8 cm and 5 cm. Find the angle between the two equal sides.
15. The angles of an isosceles triangle are 66° , 66° and 48° . If the shortest side of the triangle is 8.4 cm, find the length of one of the two equal sides.
16. A chord of length 12 cm subtends an angle of 78.2° at the centre of a circle. Find the radius of the circle.
17. Find the acute angle between the diagonals of a rectangle whose sides are 5 cm and 7 cm.
18. A kite flying at a height of 55 m is attached to a string which makes an angle of 55° with the horizontal. What is the length of the string?
19. A boy is flying a kite from a string of length 150 m. If the string is taut and makes an angle of 67° with the horizontal, what is the height of the kite?
20. A rocket flies 10 km vertically, then 20 km at an angle of 15° to the vertical and finally 60 km at an angle of 26° to the vertical. Calculate the vertical height of the rocket at the end of the third stage.

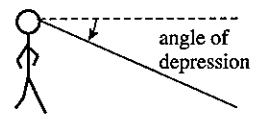

21. Find x , given
 $AD = BC = 6$ m.

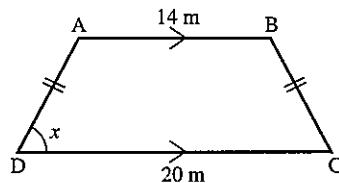

22. Find x .

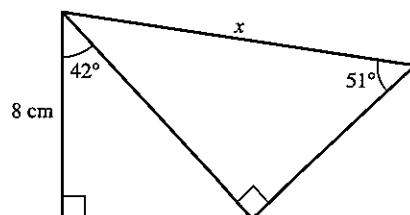

23. Ants can hear each other up to a range of 2 m. An ant at A, 1 m from a wall sees her friend at B about to be eaten by a spider. If the angle of elevation of B from A is 62° , will the spider have a meal or not? (Assume B escapes if he hears A calling.)

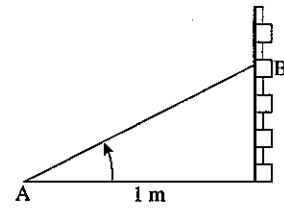

24. A hedgehog wishes to cross a road without being run over. He observes the angle of elevation of a lamp post on the other side of the road to be 27° from the edge of the road and 15° from a point 10 m back from the road. How wide is the road? If he can run at 1 m/s, how long will he take to cross?
If cars are travelling at 20 m/s, how far apart must they be if he is to survive?
25. From a point 10 m from a vertical wall, the angles of elevation of the bottom and the top of a statue of Sir Isaac Newton, set in the wall, are 40° and 52° . Calculate the height of the statue.

6.2 Scale drawing

On a scale drawing you must always state the scale you use.

Exercise 6

Make a scale drawing and then answer the questions.

1. A field has four sides as shown below:

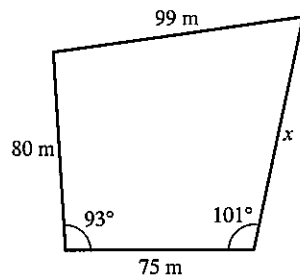

How long is the side x in metres?

2. A destroyer and a cruiser leave a port at the same time. The destroyer sails at 38 knots on a bearing of 042° and the cruiser sails at 25 knots on a bearing of 315° . How far apart are the ships two hours later? [1 knot is a speed of 1 nautical mile per hour.]
3. Two radar stations A and B are 80 km apart and B is due East of A. One aircraft is on a bearing of 030° from A and 346° from B. A second aircraft is on a bearing of 325° from A and 293° from B. How far apart are the two aircraft?
4. A ship sails 95 km on a bearing of 140° , then a further 102 km on a bearing of 260° and then returns directly to its starting point. Find the length and bearing of the return journey.

5. A control tower observes the flight of an unidentified flying object.
 At 09:23 the U.F.O. is 580 km away on a bearing of 043° .
 At 09:25 the U.F.O. is 360 km away on a bearing of 016° .
 What is the speed and the course of the U.F.O.?
 [Use a scale of 1 cm to 50 km]

6. Make a scale drawing of the diagram and find the length of CD in km.

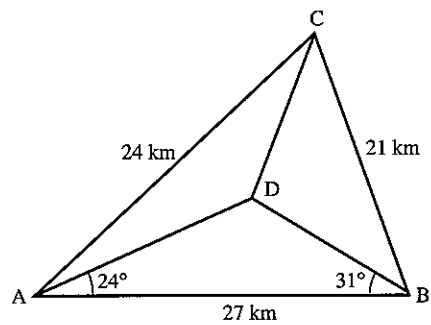

6.3 Three-dimensional problems

Always draw a large, clear diagram. It is often helpful to redraw the triangle which contains the length or angle to be found.

Example

A rectangular box with top WXYZ and base ABCD has $AB = 6$ cm, $BC = 8$ cm and $WA = 3$ cm.

Calculate:

- (a) the length of AC
 (b) the angle between WC and AC.

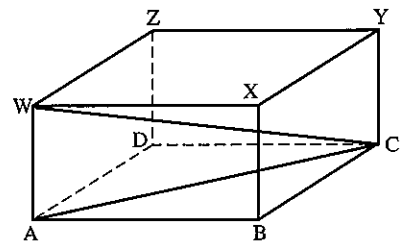

- (a) Redraw triangle ABC.

$$AC^2 = 6^2 + 8^2 = 100$$

$$AC = 10 \text{ cm}$$

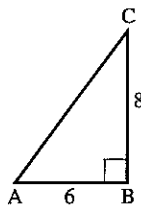

- (b) Redraw triangle WAC.

$$\text{Let } \widehat{WCA} = \theta$$

$$\tan \theta = \frac{3}{10}$$

$$\theta = 16.7^\circ$$

The angle between WC and AC is 16.7° .

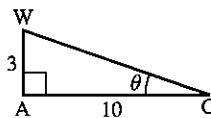

Exercise 7

1. In the rectangular box shown, find:
 (a) AC
 (b) AR
 (c) the angle between AC and AR.

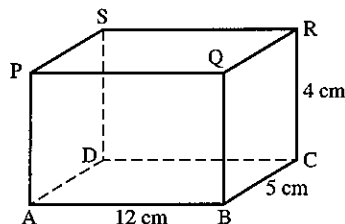

2. A vertical pole BP stands at one corner of a horizontal rectangular field as shown.

If $AB = 10\text{ m}$, $AD = 5\text{ m}$ and the angle of elevation of P from A is 22° , calculate:

- the height of the pole
- the angle of elevation of P from C
- the length of a diagonal of the rectangle ABCD
- the angle of elevation of P from D.

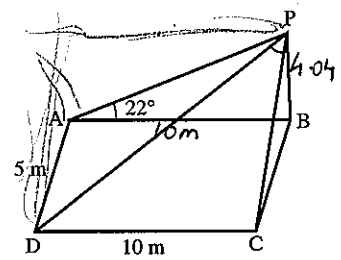

3. In the cube shown, find:

- BD
- AS
- BS
- the angle SBD
- the angle ASB

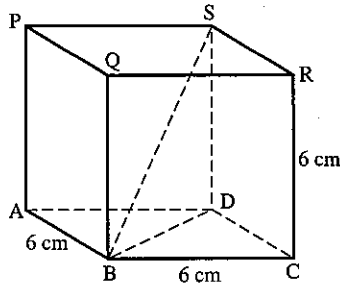

4. In the cuboid shown, find:

- WY
- DY
- WD
- the angle WDY

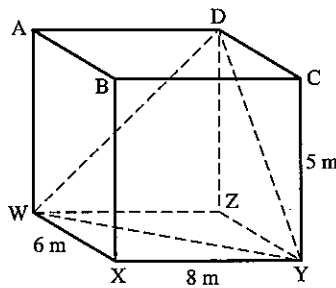

5. In the square-based pyramid, V is vertically above the middle of the base, $AB = 10\text{ cm}$ and $VC = 20\text{ cm}$. Find:

- AC
- the height of the pyramid
- the angle between VC and the base ABCD
- the angle AVB
- the angle AVC

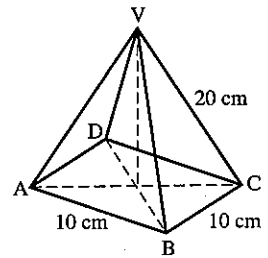

6. In the wedge shown, PQRS is perpendicular to ABRQ; PQRS and ABRQ are rectangles with $AB = QR = 6\text{ m}$, $BR = 4\text{ m}$, $RS = 2\text{ m}$. Find:

- BS
- AS
- angle BSR
- angle ASR
- angle PAS

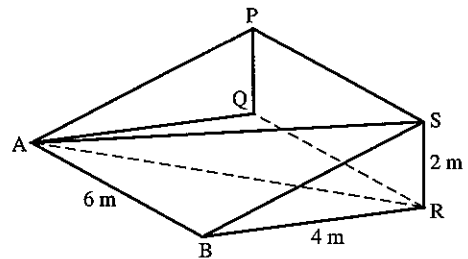

7. The edges of a box are 4 cm, 6 cm and 8 cm. Find the length of a diagonal and the angle it makes with the diagonal on the largest face.

8. In the diagram A, B and O are points in a horizontal plane and P is vertically above O, where $OP = h$ m.

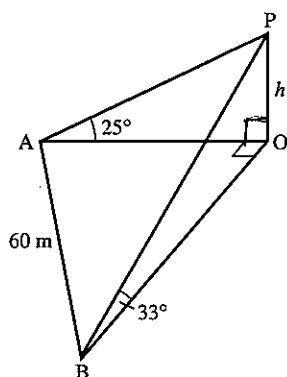

A is due West of O, B is due South of O and $AB = 60$ m. The angle of elevation of P from A is 25° and the angle of elevation of P from B is 33° .

- (a) Find the length AO in terms of h .
 - (b) Find the length BO in terms of h .
 - (c) Find the value of h .
9. The angle of elevation of the top of a tower is 38° from a point A due South of it. The angle of elevation of the top of the tower from another point B, due East of the tower is 29° . Find the height of the tower if the distance AB is 50 m.
10. An observer at the top of a tower of height 15 m sees a man due West of him at an angle of depression 31° . He sees another man due South at an angle of depression 17° . Find the distance between the men.
11. The angle of elevation of the top of a tower is 27° from a point A due East of it. The angle of elevation of the top of the tower is 11° from another point B due South of the tower. Find the height of the tower if the distance AB is 40 m.
12. The figure shows a triangular pyramid on a horizontal base ABC, V is vertically above B where $VB = 10$ cm, $\angle ABC = 90^\circ$ and $AB = BC = 15$ cm. Point M is the mid-point of AC. Calculate the size of angle VMB.

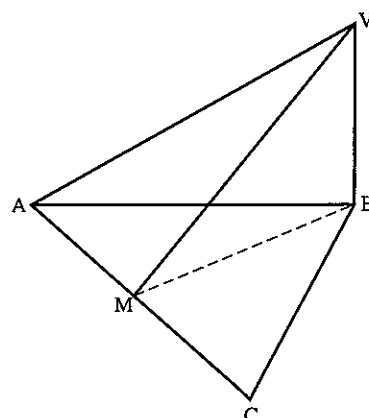
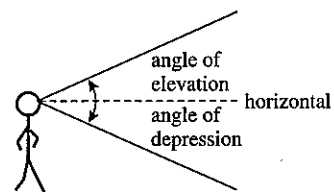

6.4 Sine, cosine, tangent for any angle

So far we have used sine, cosine and tangent only in right-angled triangles. For angles greater than 90° , we will see that there is a close connection between trigonometric ratios and circles.

The circle on the right is of radius 1 unit with centre $(0, 0)$. A point P with coordinates (x, y) moves round the circumference of the circle. The angle that OP makes with the positive x -axis as it turns in an anticlockwise direction is θ .

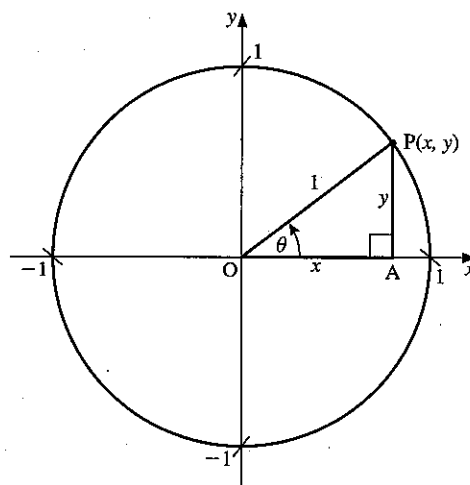

In triangle OAP , $\cos \theta = \frac{x}{1}$ and $\sin \theta = \frac{y}{1}$

The x -coordinate of P is $\cos \theta$.

The y -coordinate of P is $\sin \theta$.

This idea is used to define the cosine and the sine of any angle, including angles greater than 90° .

Here are two angles that are greater than 90° .

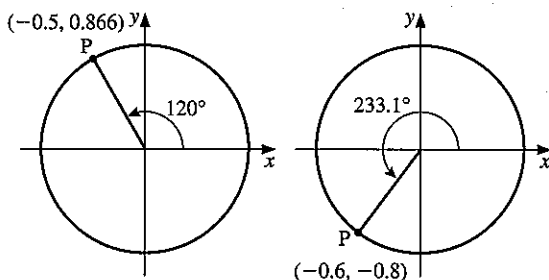

$$\begin{aligned}\cos 120^\circ &= -0.5 \\ \sin 120^\circ &= 0.866\end{aligned}$$

$$\begin{aligned}\cos 233.1^\circ &= -0.6 \\ \sin 233.1^\circ &= -0.8\end{aligned}$$

Note: Only sine and cosine of angles to 180° will be assessed in the IGCSE examination.

A graphics calculator can be used to show the graph of $y = \sin x$ for any range of angles. The graph on the right shows $y = \sin x$ for x from 0° to 360° . The curve above the x -axis has symmetry about $x = 90^\circ$ and that below the x -axis has symmetry about $x = 270^\circ$.

Note:

$$\begin{aligned}\sin 150^\circ &= \sin 30^\circ & \cos 150^\circ &= -\cos 30^\circ \\ \sin 110^\circ &= \sin 70^\circ & \cos 110^\circ &= -\cos 70^\circ \\ \sin 163^\circ &= \sin 17^\circ & \cos 163^\circ &= -\cos 17^\circ\end{aligned}$$

$$\begin{aligned}\text{or } \sin x &= \sin (180^\circ - x) \\ \text{or } \cos x &= -\cos (180^\circ - x)\end{aligned}$$

These two results are particularly important for use with obtuse angles ($90^\circ < x < 180^\circ$) in Sections 6.5 and 6.6 when applying the sine formula or the cosine formula.

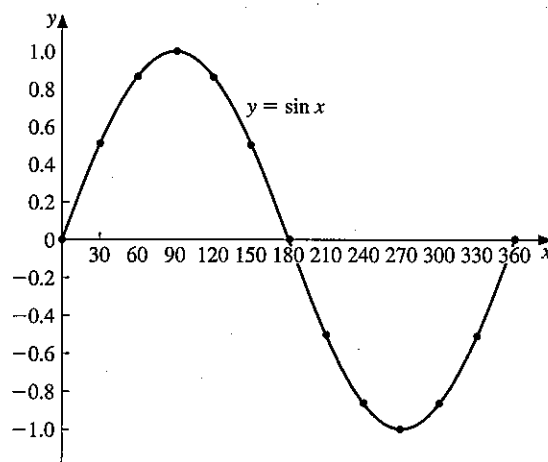

18. Draw the graph of $y = 2 \sin x + \cos x$ for $0 \leq x \leq 180^\circ$, taking 1 cm to 10° for x and 5 cm to 1 unit for y .

(a) Solve approximately the equations:

(i) $2 \sin x + \cos x = 1.5$

(ii) $2 \sin x + \cos x = 0$

(b) Estimate the maximum value of y .

(c) Find the value of x at which the maximum occurs.

19. Draw the graph of $y = 3 \cos x - 4 \sin x$ for $0^\circ \leq x \leq 220^\circ$, taking 1 cm to 10° for x and 2 cm to 1 unit for y .

Solve approximately the equations:

(a) $3 \cos x - 4 \sin x + 1 = 0$

(b) $3 \cos x = 4 \sin x$

20. Find the tangents of the angles $0^\circ, 20^\circ, 40^\circ, 60^\circ, \dots, 320^\circ, 340^\circ, 360^\circ$.

(a) Notice that we have deliberately omitted 90° and 270° . Why has this been done?

(b) Draw a graph of $y = \tan x$. Use a scale of 1 cm to 20° on the x -axis and 1 cm to 1 unit on the y -axis.

(c) Draw a vertical dotted line at $x = 90^\circ$ and $x = 270^\circ$. These lines are *asymptotes* to the curve. As the value of x approaches 90° from either side, the curve gets nearer and nearer to the asymptote but it *never* quite reaches it.

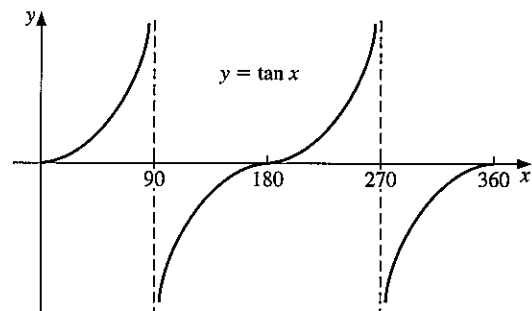

6.5 The sine rule

The sine rule enables us to calculate sides and angles in some triangles where there is not a right angle.

In $\triangle ABC$, we use the convention that

a is the side opposite \hat{A}

b is the side opposite \hat{B} , etc.

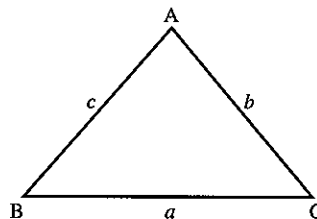

Either $\frac{a}{\sin A} = \frac{b}{\sin B} = \frac{c}{\sin C}$... [1]

or $\frac{\sin A}{a} = \frac{\sin B}{b} = \frac{\sin C}{c}$... [2]

Use [1] when finding a *side*,
and [2] when finding an *angle*.

Example 1Find c .

$$\frac{c}{\sin C} = \frac{b}{\sin B}$$

$$\frac{c}{\sin 50^\circ} = \frac{7}{\sin 60^\circ}$$

$$c = \frac{7 \times \sin 50^\circ}{\sin 60^\circ} = 6.19 \text{ cm (3 s.f.)}$$

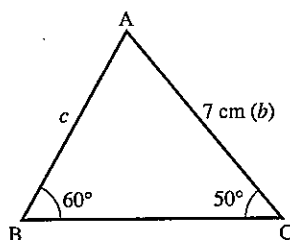

Although we cannot have an angle of more than 90° in a right-angled triangle, it is still useful to define sine, cosine and tangent for these angles.

For an obtuse angle x ,
we have $\sin x = \sin(180 - x)$

Examples $\sin 130^\circ = \sin 50^\circ$
 $\sin 170^\circ = \sin 10^\circ$
 $\sin 116^\circ = \sin 64^\circ$

Most people simply use a calculator when finding the sine of an obtuse angle.

Example 2Find \hat{B} .

$$\frac{\sin B}{b} = \frac{\sin A}{a}$$

$$\frac{\sin B}{6} = \frac{\sin 120^\circ}{15} \quad (\sin 120^\circ = \sin 60^\circ)$$

$$\sin B = \frac{6 \times \sin 60^\circ}{15}$$

$$\sin B = 0.346$$

$$\hat{B} = 20.3^\circ$$

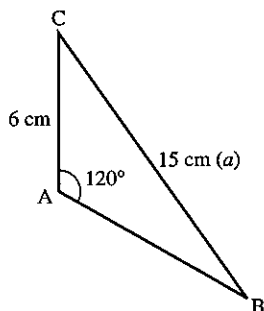
**Exercise 9**

For questions 1 to 6, find each side marked with a letter.
Give answers to 3 s.f.

1.

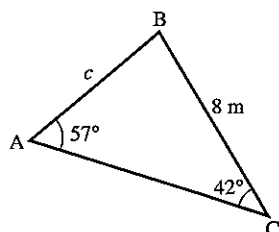

2.

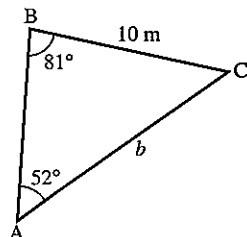

3.

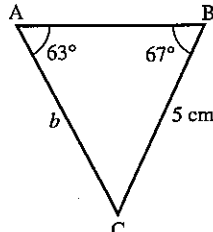

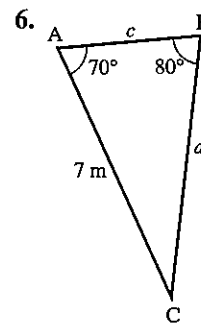
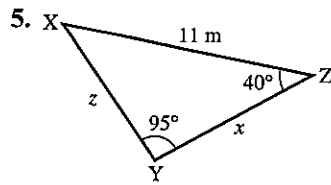
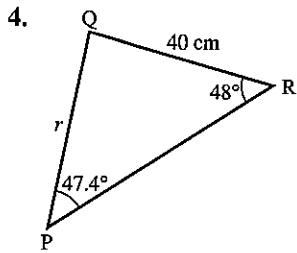

7. In $\triangle ABC$, $\hat{A} = 61^\circ$, $\hat{B} = 47^\circ$, $AC = 7.2$ cm. Find BC .
8. In $\triangle XYZ$, $\hat{Z} = 32^\circ$, $\hat{Y} = 78^\circ$, $XY = 5.4$ cm. Find XZ .
9. In $\triangle PQR$, $\hat{Q} = 100^\circ$, $\hat{R} = 21^\circ$, $PQ = 3.1$ cm. Find PR .
10. In $\triangle LMN$, $\hat{L} = 21^\circ$, $\hat{N} = 30^\circ$, $MN = 7$ cm. Find LN .

In questions 11 to 18, find each angle marked *. All lengths are in centimetres.

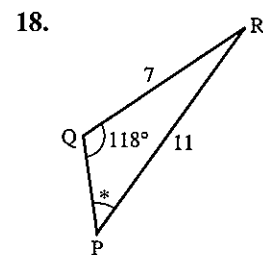
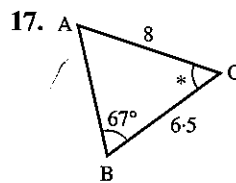
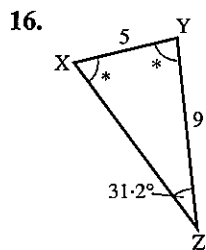
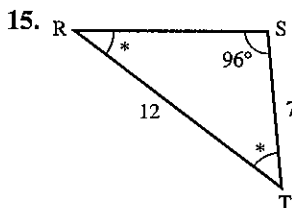
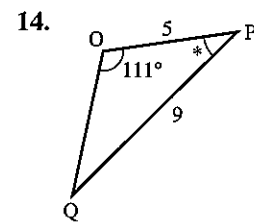
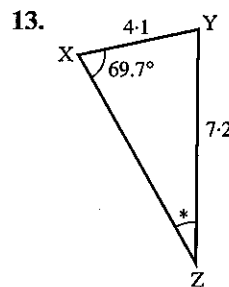
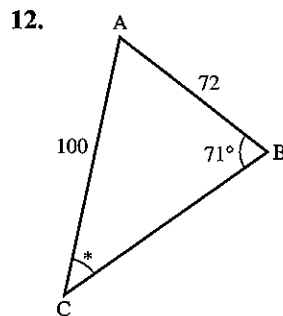
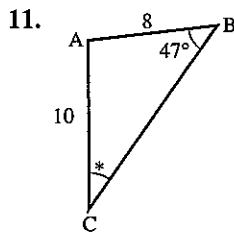

19. In $\triangle ABC$, $\hat{A} = 62^\circ$, $BC = 8$, $AB = 7$. Find \hat{C} .
20. In $\triangle XYZ$, $\hat{Y} = 97.3^\circ$, $XZ = 22$, $XY = 14$. Find \hat{Z} .
21. In $\triangle DEF$, $\hat{D} = 58^\circ$, $EF = 7.2$, $DE = 5.4$. Find \hat{F} .
22. In $\triangle LMN$, $\hat{M} = 127.1^\circ$, $LN = 11.2$, $LM = 7.3$. Find \hat{L} .

6.6 The cosine rule

We use the cosine rule when we have either

- (a) two sides and the included angle or
 (b) all three sides.

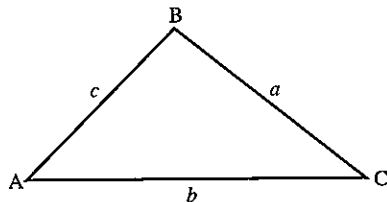

There are two forms.

1. To find the length of a side.

$$\begin{aligned} a^2 &= b^2 + c^2 - (2bc \cos A) \\ \text{or } b^2 &= c^2 + a^2 - (2ac \cos B) \\ \text{or } c^2 &= a^2 + b^2 - (2ab \cos C) \end{aligned}$$

2. To find an angle when given all three sides.

$$\begin{aligned} \cos A &= \frac{b^2 + c^2 - a^2}{2bc} \\ \text{or } \cos B &= \frac{a^2 + c^2 - b^2}{2ac} \\ \text{or } \cos C &= \frac{a^2 + b^2 - c^2}{2ab} \end{aligned}$$

For an obtuse angle x we have $\cos x = -\cos(180 - x)$

$$\begin{aligned} \text{Examples } \cos 120^\circ &= -\cos 60^\circ \\ \cos 142^\circ &= -\cos 38^\circ \end{aligned}$$

Example 1

Find b .

$$\begin{aligned} b^2 &= a^2 + c^2 - (2ac \cos B) \\ b^2 &= 8^2 + 5^2 - (2 \times 8 \times 5 \times \cos 112^\circ) \\ b^2 &= 64 + 25 - [80 \times (-0.3746)] \\ b^2 &= 64 + 25 + 29.968 \end{aligned}$$

(Notice the change of sign for the obtuse angle)

$$b = \sqrt{(118.968)} = 10.9 \text{ cm (to 3 s.f.)}$$

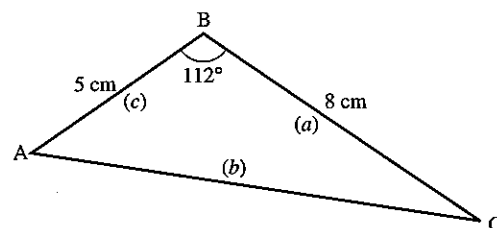

Example 2

Find angle C.

$$\begin{aligned} \cos C &= \frac{a^2 + b^2 - c^2}{2ab} \\ \cos C &= \frac{5^2 + 6^2 - 7^2}{2 \times 5 \times 6} = \frac{12}{60} = 0.200 \\ \hat{C} &= 78.5^\circ \end{aligned}$$

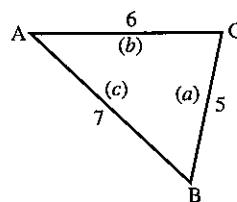

Exercise 10

Find the sides marked *. All lengths are in centimetres.

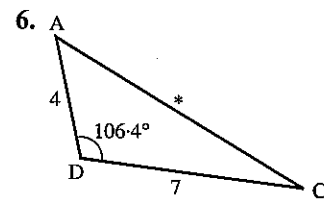
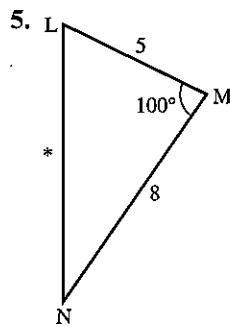
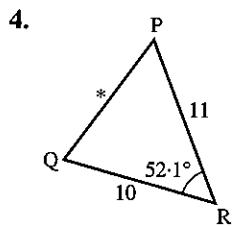
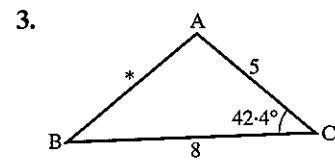
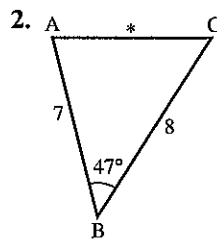
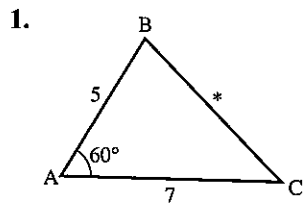

7. In $\triangle ABC$, $AB = 4$ cm, $AC = 7$ cm, $\hat{A} = 57^\circ$. Find BC .

8. In $\triangle XYZ$, $XY = 3$ cm, $YZ = 3$ cm, $\hat{Y} = 90^\circ$. Find XZ .

9. In $\triangle LMN$, $LM = 5.3$ cm, $MN = 7.9$ cm, $\hat{M} = 127^\circ$. Find LN .

10. $\triangle PQR$, $\hat{Q} = 117^\circ$, $PQ = 80$ cm, $QR = 100$ cm. Find PR .

In questions 11 to 16, find each angle marked *.

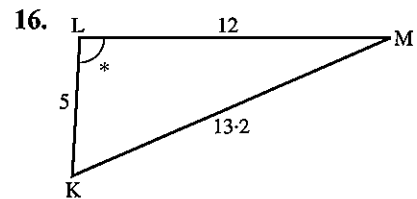
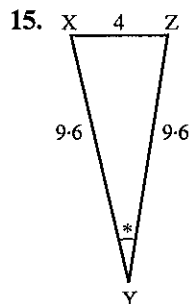
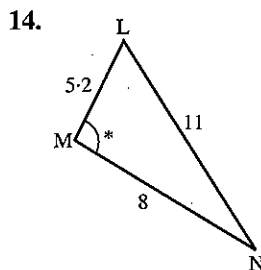
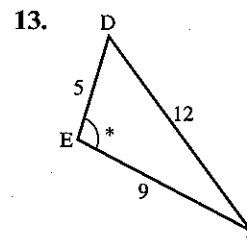
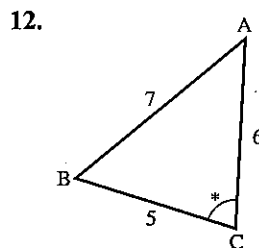
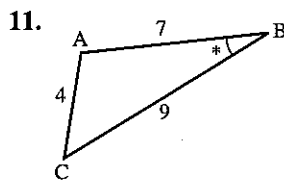

17. In $\triangle ABC$, $a = 4.3$, $b = 7.2$, $c = 9$. Find \hat{C} .
18. In $\triangle DEF$, $d = 30$, $e = 50$, $f = 70$. Find \hat{E} .
19. In $\triangle PQR$, $p = 8$, $q = 14$, $r = 7$. Find \hat{Q} .
20. In $\triangle LMN$, $l = 7$, $m = 5$, $n = 4$. Find \hat{N} .
21. In $\triangle XYZ$, $x = 5.3$, $y = 6.7$, $z = 6.14$. Find \hat{Z} .
22. In $\triangle ABC$, $a = 4.1$, $c = 6.3$, $\hat{B} = 112.2^\circ$.
Find b .
23. In $\triangle PQR$, $r = 0.72$, $p = 1.14$, $\hat{Q} = 94.6^\circ$.
Find q .
24. In $\triangle LMN$, $n = 7.206$, $l = 6.3$, $\hat{L} = 51.2^\circ$,
 $\hat{N} = 63^\circ$. Find m .

Example

A ship sails from a port P a distance of 7 km on a bearing of 306° and then a further 11 km on a bearing of 070° to arrive at X. Calculate the distance from P to X.

$$\begin{aligned} PX^2 &= 7^2 + 11^2 - (2 \times 7 \times 11 \times \cos 56^\circ) \\ &= 49 + 121 - (86.12) \end{aligned}$$

$$PX^2 = 83.88$$

$$PX = 9.16 \text{ km (to 3 s.f.)}$$

The distance from P to X is 9.16 km.

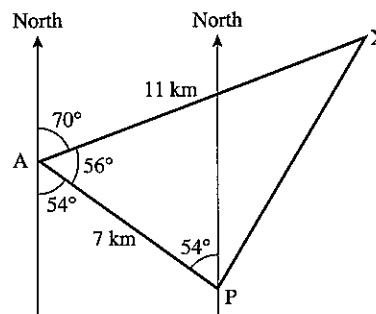

Exercise 11

Start each question by drawing a large, clear diagram.

- In triangle PQR, $\hat{Q} = 72^\circ$, $\hat{R} = 32^\circ$ and $PR = 12$ cm. Find PQ.
- In triangle LMN, $\hat{M} = 84^\circ$, $LM = 7$ m and $MN = 9$ m. Find LN.
- A destroyer D and a cruiser C leave port P at the same time. The destroyer sails 25 km on a bearing of 040° and the cruiser sails 30 km on a bearing of 320° . How far apart are the ships?
- Two honeybees A and B leave the hive H at the same time; A flies 27 m due South and B flies 9 m on a bearing of 111° . How far apart are they?
- Find all the angles of a triangle in which the sides are in the ratio 5:6:8.
- A golfer hits his ball B a distance of 170 m towards a hole H which measures 195 m from the tee T to the green. If his shot is directed 10° away from the true line to the hole, find the distance between his ball and the hole.

7. From A, B lies 11 km away on a bearing of 041° and C lies 8 km away on a bearing of 341° . Find:
 (a) the distance between B and C
 (b) the bearing of B from C.
8. From a lighthouse L an aircraft carrier A is 15 km away on a bearing of 112° and a submarine S is 26 km away on a bearing of 200° . Find:
 (a) the distance between A and S
 (b) the bearing of A from S.
9. If the line BCD is horizontal find:
 (a) AE
 (b) \widehat{EAC}

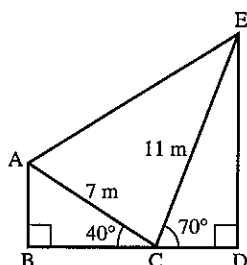

- (c) the angle of elevation of E from A.
10. An aircraft flies from its base 200 km on a bearing 162° , then 350 km on a bearing 260° , and then returns directly to base. Calculate the length and bearing of the return journey.
11. Town Y is 9 km due North of town Z. Town X is 8 km from Y, 5 km from Z and somewhere to the west of the line YZ.
 (a) Draw triangle XYZ and find angle YZX.
 (b) During an earthquake, town X moves due South until it is due West of Z. Find how far it has moved.
12. Calculate WX, given $YZ = 15$ m.

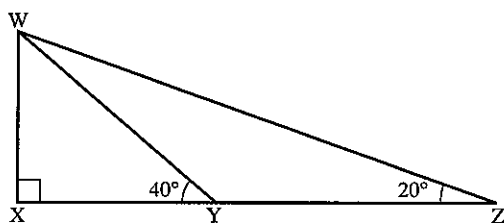

13. A golfer hits her ball a distance of 127 m so that it finishes 31 m from the hole. If the length of the hole is 150 m, calculate the angle between the line of her shot and the direct line to the hole.

Revision exercise 6A

1. Calculate the side or angle marked with a letter.

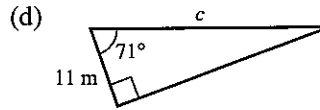
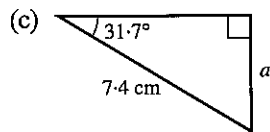
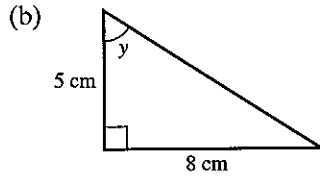
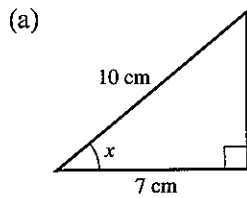

2. Given that x is an acute angle and that

$$3 \tan x - 2 = 4 \cos 35.3^\circ$$

calculate:

- (a) $\tan x$
- (b) the value of x in degrees correct to 1 D.P.

3. In the triangle XYZ, $XY = 14$ cm, $XZ = 17$ cm and angle $YXZ = 25^\circ$. A is the foot of the perpendicular from Y to XZ.

Calculate:

- (a) the length XA
- (b) the length YA
- (c) the angle ZYA

4. Calculate the length of AB.

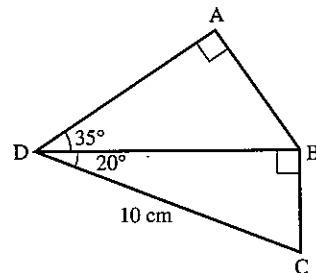

- 5. (a) A lies on a bearing of 040° from B. Calculate the bearing of B from A.
- (b) The bearing of X from Y is 115° . Calculate the bearing of Y from X.

6. Given $BD = 1$ m, calculate the length AC.

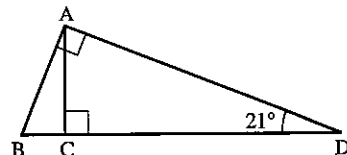

7. In the triangle PQR, angle $\widehat{PQR} = 90^\circ$ and angle $\widehat{RPQ} = 31^\circ$. The length of PQ is 11 cm. Calculate:
- the length of QR
 - the length of PR
 - the length of the perpendicular from Q to PR.

8. $\widehat{BAD} = \widehat{DCA} = 90^\circ$, $\widehat{CAD} = 32.4^\circ$, $\widehat{BDA} = 41^\circ$ and $AD = 100$ cm.
Calculate:
- the length of AB
 - the length of DC
 - the length of BD.

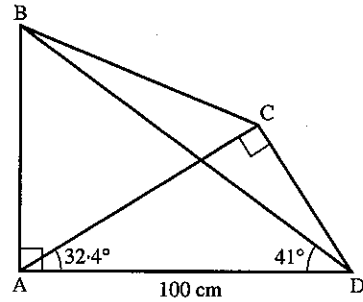

9. An observer at the top of a tower of height 20 m sees a man due East of him at an angle of depression of 27° . He sees another man due South of him at an angle of depression of 30° . Find the distance between the men on the ground.
10. The figure shows a cube of side 10 cm.
Calculate:
- the length of AC
 - the angle YAC
 - the angle ZBD.

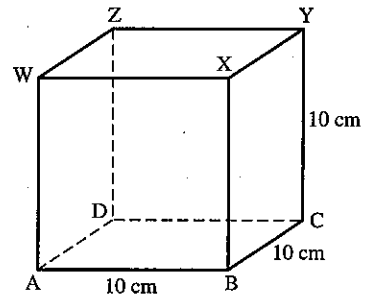

11. The diagram shows a rectangular block.
 $AY = 12$ cm, $AB = 8$ cm, $BC = 6$ cm.
Calculate:
- the length YC
 - the angle \widehat{YAZ} .

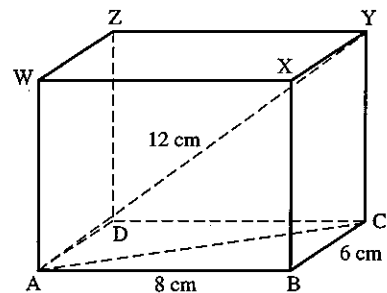

12. VABCD is a pyramid in which the base ABCD is a square of side 8 cm; V is vertically above the centre of the square and $VA = VB = VC = VD = 10$ cm.
Calculate:
- the length AC
 - the height of V above the base
 - the angle \widehat{VCA} .

Questions 13 to 18 may be answered either by scale drawing or by using the sine and cosine rules.

13. Two lighthouses A and B are 25 km apart and A is due West of B. A submarine S is on a bearing of 137° from A and on a bearing of 170° from B. Find the distance of S from A and the distance of S from B.
14. In triangle PQR, $PQ = 7$ cm, $PR = 8$ cm and $QR = 9$ cm. Find angle QPR.
15. In triangle XYZ, $XY = 8$ m, $\hat{X} = 57^\circ$ and $\hat{Z} = 50^\circ$. Find the lengths YZ and XZ.
16. In triangle ABC, $\hat{A} = 22^\circ$ and $\hat{C} = 44^\circ$.
Find the ratio $\frac{BC}{AB}$.
17. Given $\cos \hat{ACB} = 0.6$, $AC = 4$ cm, $BC = 5$ cm and $CD = 7$ cm, find the length of AB and AD.

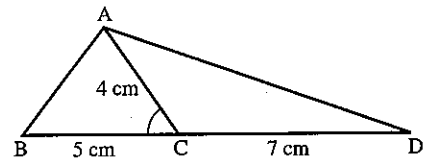

18. Find the smallest angle in a triangle whose sides are of length $3x$, $4x$ and $6x$.

Examination exercise 6B

1.

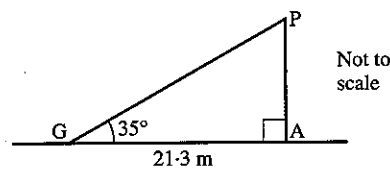

A wire, GP, connects the top of a vertical pole, AP, to the horizontal ground.

$GA = 21.3$ m and angle $PGA = 35^\circ$.

Calculate GP, the length of the wire.

J 97 2

2. Two vans, 5 m apart and each 2 m wide, are parked at the side of a road. The diagram shows the vans from above.

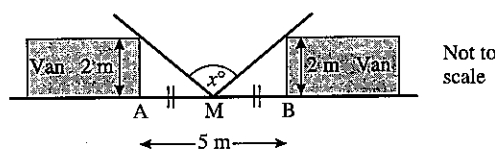

- (a) A man stands on the pavement at M, halfway between A and B. Calculate his angle of view (x°).
- (b) Calculate his angle of view if he stood at the point B.

N 98 2

3. $\cos A = \sqrt{\frac{1}{4 - 2\sqrt{2}}}$

Calculate the value of angle A.

N 98 2

4.

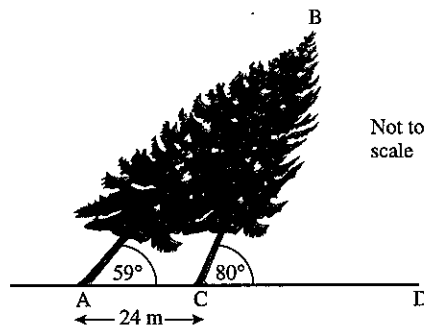

During a storm, a tree, AB, is blown over and rests on another tree CB. $\widehat{BAC} = 59^\circ$, $\widehat{BCD} = 80^\circ$, $AC = 24$ m and ACD is horizontal. Calculate the length AB.

J 95 2

5.

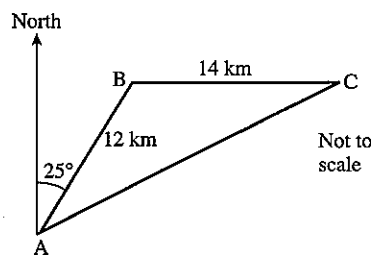

Hussein travels 12 km from A to B on a bearing of 025° . He then travels due East for 14 km to C.

- (a) Show that angle ABC is 115° .
- (b) Calculate:
 - (i) the distance AC,
 - (ii) the angle BAC,
 - (iii) the bearing of A from C.

J 97 4

6. The diagram represents three straight roads which surround a village.

The bearing of A from C is 021° . Angle $ACB = 41^\circ$. The lengths of the roads CA and CB are 450 m and 600 m respectively.

- (a) Calculate the bearing of
 - (i) B from C,
 - (ii) C from A.
- (b) Calculate how far A is north of C.
- (c) Calculate the length of the road AB.
- (d) The area ABC contains homes for 374 people. Calculate the average number of people per hectare in the area. (1 hectare = $10\,000\text{ m}^2$.)

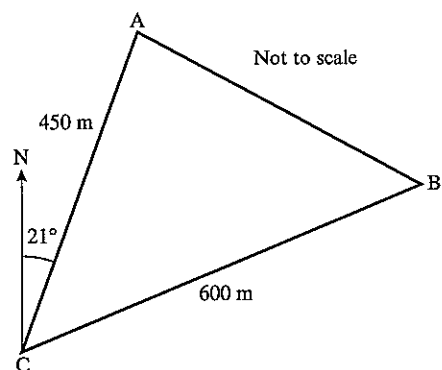

N 95 4

7.

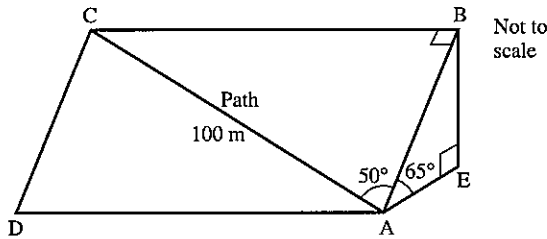

- On a hillside ABCD a path, AC, is 100 m long.
 The path makes an angle of 50° with AB. Angle $ABC = 90^\circ$.
- Calculate the length of AB.
 - The hillside slopes upwards at an angle of 65° and angle $AEB = 90^\circ$.
 Calculate the height, BE, of the hill.

N 97 2

8. The diagram shows a regular octahedron.
 All the edges are 3 cm long.

- For this solid, write down the number of:
 - faces,
 - vertices,
 - edges.
- The octahedron is split into two equal parts.
 One of the parts is shown in the diagram on the right.
 Calculate:
 - the length of AC,
 - the vertical height OH,
 - the angle between OA and the base ABCD.
- The volume of a pyramid is $\frac{1}{3}$ base area \times height.
 Calculate the volume of the octahedron.

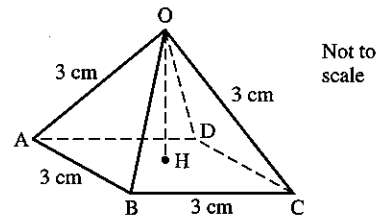
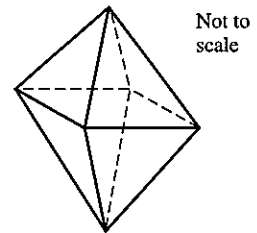

N 98 4

9. Find x when $\sin x^\circ = -0.866$, $\cos x^\circ = -0.5$ and $0 \leq x \leq 360$.

J 98 2

10. The diagram shows the graphs of $y = \sin x^\circ$ and $y = \cos x^\circ$.

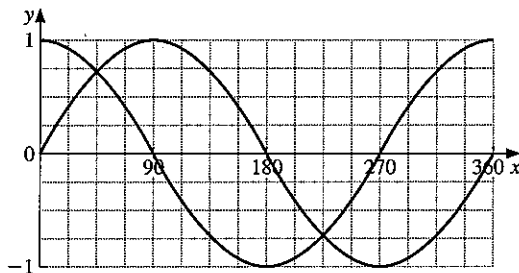

Find the values of x between 0 and 360 for which

- $\sin x^\circ = \cos x^\circ$,
- $\sin x^\circ = \sin 22.5^\circ$ ($x \neq 22.5$).

N 03 2

7 GRAPHS

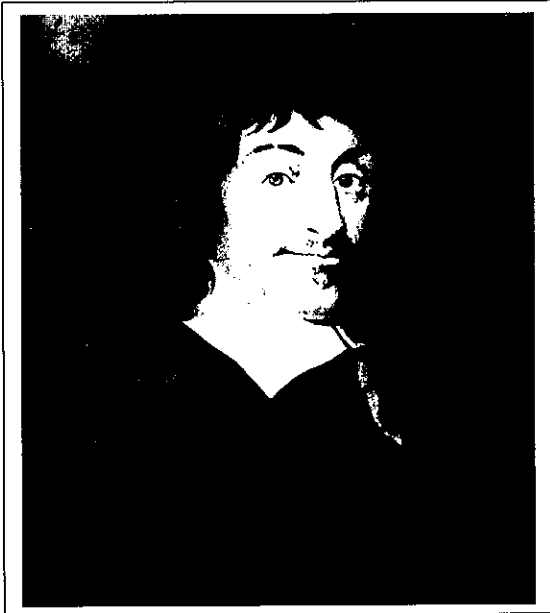

Rene Descartes (1596–1650) was one of the greatest philosophers of his time. Strangely his restless mind only found peace and quiet as a soldier and he apparently discovered the idea of ‘cartesian’ geometry in a dream before the battle of Prague. The word ‘cartesian’ is derived from his name and his work formed the link between geometry and algebra which inevitably led to the discovery of calculus. He finally settled in Holland for ten years, but later moved to Sweden where he soon died of pneumonia.

- 17 Apply rate of change to distance–time and speed–time graphs
- 18 Construct tables of values and draw graphs for functions of the form ax^n ; estimate gradients of curves by drawing tangents
- 19 Interpret and obtain the equation of a straight-line graph in the form $y = mx + c$; calculate the gradient of a straight line from the coordinates of two points on it

7.1 Drawing accurate graphs

Example

Draw the graph of $y = 2x - 3$ for values of x from -2 to $+4$.

- (a) The coordinates of points on the line are calculated in a table.

x	-2	-1	0	1	2	3	4
$2x$	-4	-2	0	2	4	6	8
-3	-3	-3	-3	-3	-3	-3	-3
y	-7	-5	-3	-1	1	3	5

- (b) Draw and label axes using suitable scales.
 (c) Plot the points and draw a pencil line through them. Label the line with its equation.

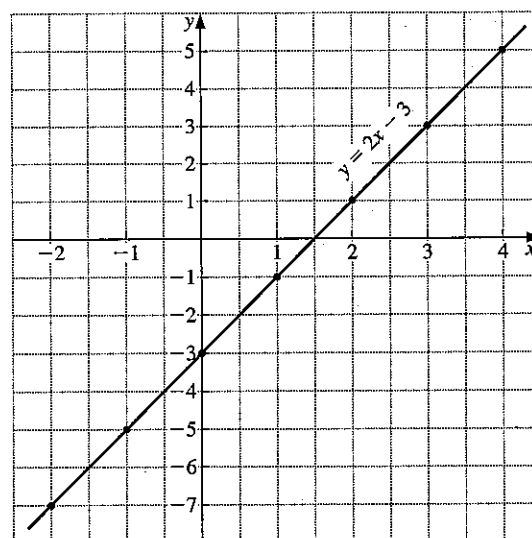

Exercise 1

Draw the following graphs, using a scale of 2 cm to 1 unit on the x -axis and 1 cm to 1 unit on the y -axis.

- | | |
|--|--|
| 1. $y = 2x + 1$ for $-3 \leq x \leq 3$ | 2. $y = 3x - 4$ for $-3 \leq x \leq 3$ |
| 3. $y = 2x - 1$ for $-3 \leq x \leq 3$ | 4. $y = 8 - x$ for $-2 \leq x \leq 4$ |
| 5. $y = 10 - 2x$ for $-2 \leq x \leq 4$ | 6. $y = \frac{x+5}{2}$ for $-3 \leq x \leq 3$ |
| 7. $y = 3(x - 2)$ for $-3 \leq x \leq 3$ | 8. $y = \frac{1}{2}x + 4$ for $-3 \leq x \leq 3$ |
| 9. $v = 2t - 3$ for $-2 \leq t \leq 4$ | 10. $z = 12 - 3t$ for $-2 \leq t \leq 4$ |

In each question from **11** to **16**, draw the graphs on the same page and hence find the coordinates of the vertices of the polygon formed. Give the answers as accurately as your graph will allow.

- | | | | |
|--|-------------------|--------------------|------------------------|
| 11. (a) $y = x$
Take $-1 \leq x \leq 3$ and $-4 \leq y \leq 14$. | (b) $y = 8 - 4x$ | (c) $y = 4x$ | |
| 12. (a) $y = 2x + 1$
Take $0 \leq x \leq 5$ and $-8 \leq y \leq 12$. | (b) $y = 4x - 8$ | (c) $y = 1$ | |
| 13. (a) $y = 3x$
Take $-2 \leq x \leq 5$ and $-9 \leq y \leq 8$. | (b) $y = 5 - x$ | (c) $y = x - 4$ | |
| 14. (a) $y = -x$
Take $-2 \leq x \leq 5$ and $-6 \leq y \leq 10$. | (b) $y = 3x + 6$ | (c) $y = 8$ | (d) $x = 3\frac{1}{2}$ |
| 15. (a) $y = \frac{1}{2}(x - 8)$
Take $-3 \leq x \leq 4$ and $-7 \leq y \leq 7$. | (b) $2x + y = 6$ | (c) $y = 4(x + 1)$ | |
| 16. (a) $y = 2x + 7$
Take $-2 \leq x \leq 4$ and $0 \leq y \leq 13$. | (b) $3x + y = 10$ | (c) $y = x$ | (d) $2y + x = 4$ |

17. The equation connecting the annual distance travelled M km, of a certain car and the

$$\text{annual running cost, } \$C \text{ is } C = \frac{M}{20} + 200.$$

Draw the graph for $0 \leq M \leq 10\,000$ using scales of 1 cm for 1000 km for M and 2 cm for \$100 for C .

From the graph find:

- (a) the cost when the annual distance travelled is 7200 km,
(b) the annual mileage corresponding to a cost of \$320.

18. The equation relating the cooking time t hours and the weight w kg for a joint of meat

$$\text{is } t = \frac{3w + 1}{4}.$$

Draw the graph for $0 \leq w \leq 5$. From the graph find:

- (a) the weight of a joint requiring a cooking time of 2.8 hours,
(b) the cooking time for a joint of weight 4.1 kg.

19. Some drivers try to estimate their annual cost of repairs \$ c in relation to their average speed of driving s km/h using the equation $c = 6s + 50$. Draw the graph for $0 \leq s \leq 160$. From the graph find:
- the estimated repair bill for a man who drives at an average speed of 65 km/h,
 - the average speed at which a motorist drives if his annual repair bill is \$300,
 - the annual saving for a man who, on returning from a holiday, reduces his average speed of driving from 100 km/h to 65 km/h.

20. The value of a car \$ v is related to the number of km n which it has travelled by the equation

$$v = 4500 - \frac{n}{20}.$$

Draw the graph for $0 \leq n \leq 90\,000$. From the graph find:

- the value of a car which has travelled 3700 km,
- the number of km travelled by a car valued at \$3200.

7.2 Gradients

The gradient of a straight line is a measure of how steep it is.

Example 1

Find the gradient of the line joining the points A(1, 2) and B(6, 5).

$$\text{gradient of AB} = \frac{BC}{AC} = \frac{3}{5}$$

It is possible to use the formula

$$\text{gradient} = \frac{\text{difference in } y\text{-coordinates}}{\text{difference in } x\text{-coordinates}}$$

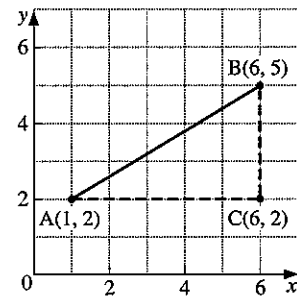

Example 2

Find the gradient of the line joining the points D(1, 5) and E(5, 2).

$$\text{gradient of DE} = \frac{5-2}{1-5} = \frac{3}{-4} = -\frac{3}{4}$$

Note:

- Lines which slope upward to the right have a *positive* gradient.
- Lines which slope downward to the right have a *negative* gradient.

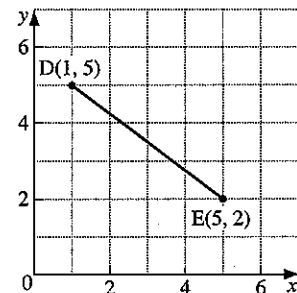

Exercise 2

Calculate the gradient of the line joining the following pairs of points.

- | | | |
|--|---|---------------------------------------|
| 1. $(3, 1)(5, 4)$ | 2. $(1, 1)(3, 5)$ | 3. $(3, 0)(4, 3)$ |
| 4. $(-1, 3)(1, 6)$ | 5. $(-2, -1)(0, 0)$ | 6. $(7, 5)(1, 6)$ |
| 7. $(2, -3)(1, 4)$ | 8. $(0, -2)(-2, 0)$ | 9. $(\frac{1}{2}, 1)(\frac{3}{4}, 2)$ |
| 10. $(-\frac{1}{2}, 1)(0, -1)$ | 11. $(3.1, 2)(3.2, 2.5)$ | 12. $(-7, 10)(0, 0)$ |
| 13. $(\frac{1}{3}, 1)(\frac{1}{2}, 2)$ | 14. $(3, 4)(-2, 4)$ | 15. $(2, 5)(1.3, 5)$ |
| 16. $(2, 3)(2, 7)$ | 17. $(-1, 4)(-1, 7.2)$ | 18. $(2.3, -2.2)(1.8, 1.8)$ |
| 19. $(0.75, 0)(0.375, -2)$ | 20. $(17.6, 1)(1.4, 1)$ | 21. $(a, b)(c, d)$ |
| 22. $(m, n)(a, -b)$ | 23. $(2a, f)(a, -f)$ | 24. $(2k, -k)(k, 3k)$ |
| 25. $(m, 3n)(-3m, 3n)$ | 26. $(\frac{c}{2}, -d)(\frac{c}{4}, \frac{d}{2})$ | |

In questions 27 and 28, find the gradient of each straight line.

27.

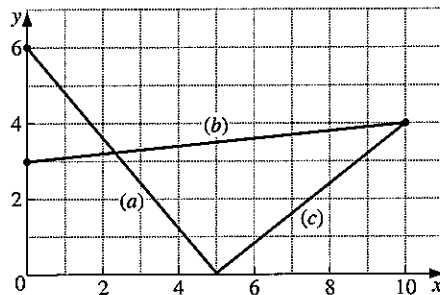

28.

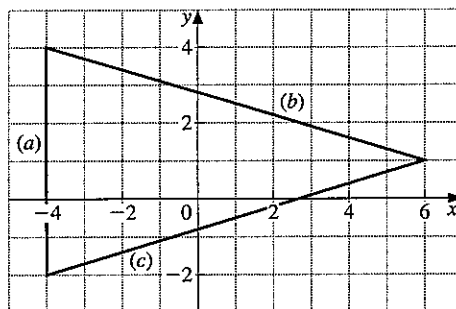

29. Find the value of a if the line joining the points $(3a, 4)$ and $(a, -3)$ has a gradient of 1.
30. (a) Write down the gradient of the line joining the points $(2m, n)$ and $(3, -4)$,
 (b) Find the value of n if the line is parallel to the x -axis,
 (c) Find the value of m if the line is parallel to the y -axis.

7.3 The form $y = mx + c$

When the equation of a straight line is written in the form $y = mx + c$, the gradient of the line is m and the intercept on the y -axis is c .

Example 1

Draw the line $y = 2x + 3$ on a *sketch* graph.

The word 'sketch' implies that we do not plot a series of points but simply show the position and slope of the line.

The line $y = 2x + 3$ has a gradient of 2 and cuts the y -axis at $(0, 3)$.

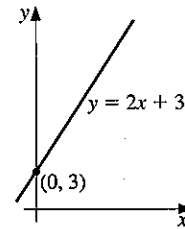

Example 2

Draw the line $x + 2y - 6 = 0$ on a sketch graph.

(a) Rearrange the equation to make y the subject.

$$\begin{aligned} x + 2y - 6 &= 0 \\ 2y &= -x + 6 \\ y &= -\frac{1}{2}x + 3 \end{aligned}$$

(b) The line has a gradient of $-\frac{1}{2}$ and cuts the y -axis at $(0, 3)$.

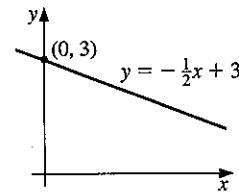

Exercise 3

In questions 1 to 20, find the gradient of the line and the intercept on the y -axis. Hence draw a small sketch graph of each line.

- | | | | |
|---------------------------|---------------------------|-------------------|----------------------|
| 1. $y = x + 3$ | 2. $y = x - 2$ | 3. $y = 2x + 1$ | 4. $y = 2x - 5$ |
| 5. $y = 3x + 4$ | 6. $y = \frac{1}{2}x + 6$ | 7. $y = 3x - 2$ | 8. $y = 2x$ |
| 9. $y = \frac{1}{4}x - 4$ | 10. $y = -x + 3$ | 11. $y = 6 - 2x$ | 12. $y = 2 - x$ |
| 13. $y + 2x = 3$ | 14. $3x + y + 4 = 0$ | 15. $2y - x = 6$ | 16. $3y + x - 9 = 0$ |
| 17. $4x - y = 5$ | 18. $3x - 2y = 8$ | 19. $10x - y = 0$ | 20. $y - 4 = 0$ |

Finding the equation of a line

Example

Find the equation of the straight line which passes through $(1, 3)$ and $(3, 7)$.

(a) Let the equation of the line take the form $y = mx + c$.

$$\text{The gradient, } m = \frac{7 - 3}{3 - 1} = 2$$

so we may write the equation as

$$y = 2x + c \quad \dots [1]$$

(b) Since the line passes through $(1, 3)$, substitute 3 for y and 1 for x in [1].

$$\begin{aligned} \therefore 3 &= 2 \times 1 + c \\ 1 &= c \end{aligned}$$

The equation of the line is $y = 2x + 1$.

Exercise 4

In questions 1 to 11 find the equation of the line which:

1. Passes through (0, 7) at a gradient of 3
2. Passes through (0, -9) at a gradient of 2
3. Passes through (0, 5) at a gradient of -1
4. Passes through (2, 3) at a gradient of 2
5. Passes through (2, 11) at a gradient of 3
6. Passes through (4, 3) at a gradient of -1
7. Passes through (6, 0) at a gradient of $\frac{1}{2}$
8. Passes through (2, 1) and (4, 5)
9. Passes through (5, 4) and (6, 7)
10. Passes through (0, 5) and (3, 2)
11. Passes through (3, -3) and (9, -1)

7.4 Linear laws**Exercise 5**

In Questions 1 to 3 find the equation of the line in the form $y = \dots\dots\dots$

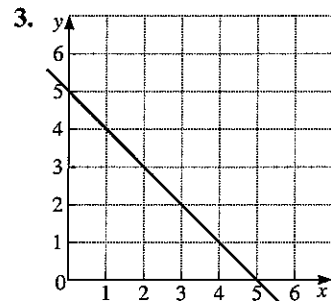
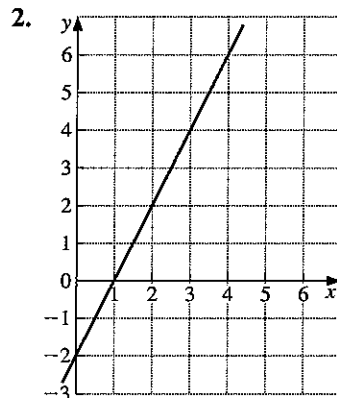
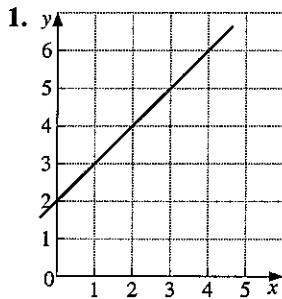

4. In an experiment, the following measurements of the variables q and t were taken:

q	0.5	1.0	1.5	2.0	2.5	3.0
t	3.85	5.0	6.1	7.0	7.75	9.1

A scientist suspects that q and t are related by an equation of the form $t = mq + c$, (m and c constants). Plot the values obtained from the experiment and draw the line of best fit through the points. Plot q on the horizontal axis with a scale of 4 cm to 1 unit, and t on the vertical axis with a scale of 2 cm to 1 unit. Find the gradient and intercept on the t -axis and hence estimate the values of m and c .

5. In an experiment, the following measurements of p and z were taken:

z	1.2	2.0	2.4	3.2	3.8	4.6
p	11.5	10.2	8.8	7.0	6	3.5

Plot the points on a graph with z on the horizontal axis and draw the line of best fit through the points. Hence estimate the values of n and k if the equation relating p and z is of the form $p = nz + k$.

6. In an experiment the following measurements of t and z were taken:

t	1.41	2.12	2.55	3.0	3.39	3.74
z	3.4	3.85	4.35	4.8	5.3	5.75

Draw a graph, plotting t^2 on the horizontal axis and z on the vertical axis, and hence confirm that the equation connecting t and z is of the form $z = mt^2 + c$. Find approximate values for m and c .

7.5 Plotting curves

Example

Draw the graph of the function
 $y = 2x^2 + x - 6$, for $-3 \leq x \leq 3$.

(a)

x	-3	-2	-1	0	1	2	3
$2x^2$	18	8	2	0	2	8	18
x	-3	-2	-1	0	1	2	3
-6	-6	-6	-6	-6	-6	-6	-6
y	9	0	-5	-6	-3	-4	15

- (b) Draw and label axes using suitable scales.
 (c) Plot the points and draw a smooth curve through them with a pencil.
 (d) Check any points which interrupt the smoothness of the curve.
 (e) Label the curve with its equation.

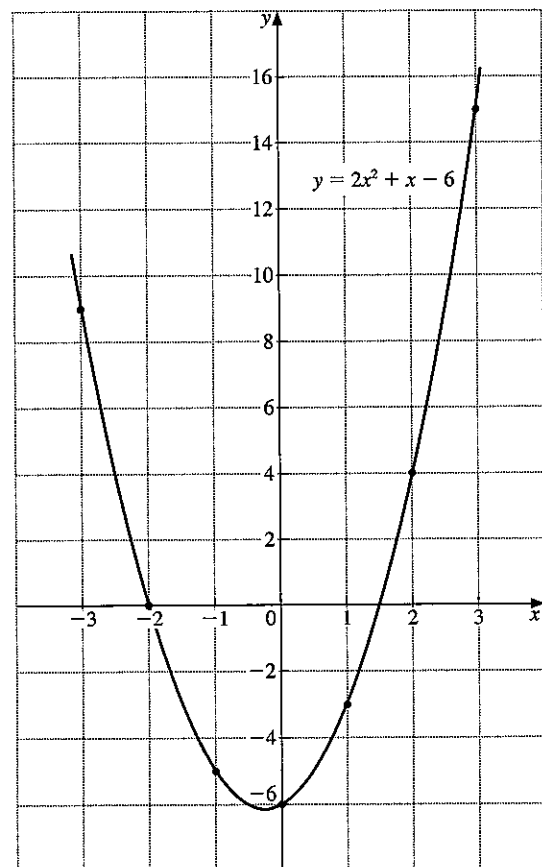

Sometimes the function notation $f(x)$ is used. $f(x)$ means 'a function of x '.

If, for example, $f(x) = x^2 + 2x$ then the graph of $y = f(x)$ is simply the graph of $y = x^2 + 2x$.

To find the value of y when $x = 1$ we obtain,

$$f(1) = 1^2 + 2 \times 1 = 3, \text{ so } y = 3$$

Similarly,

$$f(2) = 2^2 + 2 \times 2 = 8$$

$$f(3) = 3^2 + 2 \times 3 = 15, \text{ and so on.}$$

Functions are explained in greater detail on page 265.

An alternative way of writing $f(x) = x^2 + 2x$ is $f: x \rightarrow x^2 + 2x$

Exercise 6

Draw the graphs of the following functions using a scale of 2 cm for 1 unit on the x -axis and 1 cm for 1 unit on the y -axis.

- $y = x^2 + 2x$, for $-3 \leq x \leq 3$
- $y = x^2 + 4x$, for $-3 \leq x \leq 3$
- $y = x^2 - 3x$, for $-3 \leq x \leq 3$
- $y = x^2 + 2$, for $-3 \leq x \leq 3$
- $y = x^2 - 7$, for $-3 \leq x \leq 3$
- $y = x^2 + x - 2$, for $-3 \leq x \leq 3$
- $y = x^2 + 3x - 9$, for $-4 \leq x \leq 3$
- $y = x^2 - 3x - 4$, for $-2 \leq x \leq 4$
- $y = x^2 - 5x + 7$, for $0 \leq x \leq 6$
- $y = 2x^2 - 6x$, for $-1 \leq x \leq 5$
- $y = 3x^2 - 6x + 5$, for $-1 \leq x \leq 3$
- $y = 2 + x - x^2$, for $-3 \leq x \leq 3$
- $f(x) = 1 - 3x - x^2$, for $-5 \leq x \leq 2$
- $f(x) = 3 + 3x - x^2$, for $-2 \leq x \leq 5$
- $f(x) = 7 - 3x - 2x^2$, for $-3 \leq x \leq 3$
- $f: x \rightarrow 8 + 2x - 3x^2$, for $-2 \leq x \leq 3$
- $f: x \rightarrow 6 + x - 2x^2$, for $-3 \leq x \leq 3$
- $f: x \rightarrow (x + 1)(2x - 5)$, for $-3 \leq x \leq 3$

Example

Draw the graph of $y = \frac{12}{x} + x - 6$, for $1 \leq x \leq 8$.

Use the graph to find approximate values for:

- the minimum value of $\frac{12}{x} + x - 6$
- the value of $\frac{12}{x} + x - 6$, when $x = 2.25$
- the gradient of the tangent to the curve drawn at the point where $x = 5$.

Here is the table of values:

x	1	2	3	4	5	6	7	8	1.5
$\frac{12}{x}$	12	6	4	3	2.4	2	1.71	1.5	8
x	1	2	3	4	5	6	7	8	1.5
-6	-6	-6	-6	-6	-6	-6	-6	-6	-6
y	7	2	1	1	1.4	2	2.71	3.5	3.5

Notice that an 'extra' value of y has been calculated at $x = 1.5$ because of the large difference between the y -values at $x = 1$ and $x = 2$.

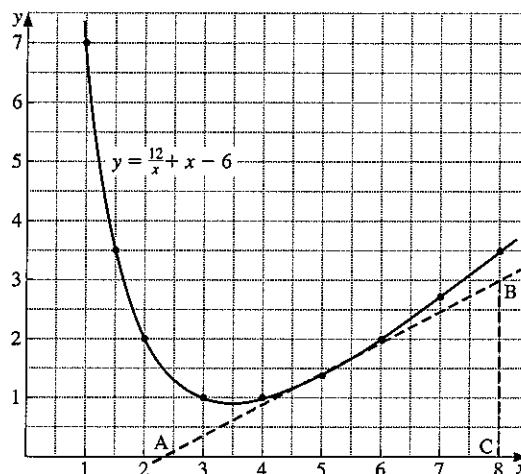

- (a) From the graph, the minimum value of $\frac{12}{x} + x - 6$ (i.e. y) is approximately 0.9.
- (b) At $x = 2.25$, y is approximately 1.6.
- (c) The tangent AB is drawn to touch the curve at $x = 5$

$$\text{The gradient of AB} = \frac{BC}{AC}$$

$$\text{gradient} = \frac{3}{8 - 2.4} = \frac{3}{5.6} \approx 0.54$$

It is difficult to obtain an accurate value for the gradient of a tangent so the above result is more realistically 'approximately 0.5'.

Exercise 7

Draw the following curves. The scales given are for one unit of x and y .

- $y = x^2$, for $0 \leq x \leq 6$.
(Scales: 2 cm for x , $\frac{1}{2}$ cm for y)
Find:

 - the gradient of the tangent to the curve at $x = 2$,
 - the gradient of the tangent to the curve at $x = 4$,
 - the y -value at $x = 3.25$.
- $y = x^2 - 3x$, for $-2 \leq x \leq 5$.
(Scales: 2 cm for x , 1 cm for y)
Find:

 - the gradient of the tangent to the curve at $x = 3$,
 - the gradient of the tangent to the curve at $x = -1$,
 - the value of x where the gradient of the curve is zero.
- $y = 5 + 3x - x^2$, for $-2 \leq x \leq 5$.
(Scales: 2 cm for x , 1 cm for y)
Find:

 - the maximum value of the function $5 + 3x - x^2$,
 - the gradient of the tangent to the curve at $x = 2.5$,
 - the two values of x for which $y = 2$.
- $y = \frac{12}{x}$, for $1 \leq x \leq 10$.
(Scales: 1 cm for x and y)
- $y = \frac{9}{x}$, for $1 \leq x \leq 10$.
(Scales: 1 cm for x and y)
- $y = \frac{12}{x+1}$, for $0 \leq x \leq 8$.
(Scales: 2 cm for x , 1 cm for y)
- $y = \frac{8}{x-4}$, for $-4 \leq x \leq 3.5$.
(Scales: 2 cm for x , 1 cm for y)

8. $y = \frac{15}{3-x}$, for $-4 \leq x \leq 2$.

(Scales: 2 cm for x , 1 cm for y)

9. $y = \frac{x}{x+4}$, for $-3.5 \leq x \leq 4$.

(Scales: 2 cm for x and y)

10. $y = \frac{3x}{5-x}$, for $-3 \leq x \leq 4$.

(Scales: 2 cm for x , 1 cm for y)

11. $y = \frac{x+8}{x+1}$, for $0 \leq x \leq 8$.

(Scales: 2 cm for x and y)

12. $y = \frac{x-3}{x+2}$, for $-1 \leq x \leq 6$.

(Scales: 2 cm for x and y)

13. $y = \frac{10}{x} + x$, for $1 \leq x \leq 7$.

(Scales: 2 cm for x , 1 cm for y)

14. $y = \frac{12}{x} - x$, for $1 \leq x \leq 7$.

(Scales: 2 cm for x , 1 cm for y)

15. $y = \frac{15}{x} + x - 7$, for $1 \leq x \leq 7$.

(Scales: 1 cm for x and y)Find: (a) the minimum value of y ,(b) the y value when $x = 5.5$.

16. $y = x^3 - 2x^2$, for $0 \leq x \leq 4$.

(Scales: 2 cm for x , $\frac{1}{2}$ cm for y)Find: (a) the y value at $x = 2.5$,(b) the x value at $y = 15$.

17. $y = \frac{1}{10}(x^3 + 2x + 20)$, for $-3 \leq x \leq 3$.

(Scales: 2 cm for x and y)

Find:

(a) the x -value where $x^3 + 2x + 20 = 0$,(b) the gradient of the tangent to the curve at $x = 2$.

18. Copy and complete the table for the function
- $y = 7 - 5x - 2x^2$
- , giving values of
- y
- correct to one decimal place.

x	-4	-3.5	-3	-2.5	-2	-1.5
7	7	7		7		7
$-5x$	20	17.5		12.5		7.5
$-2x^2$	-32	-24.5		-12.5		-4.5
y	5	0		7		10

x	-1	-0.5	0	0.5	1	1.5	2
7		7		7		7	
$-5x$		2.5		-2.5		-7.5	
$-2x^2$		-0.5		-0.5		-4.5	
y		9		4		-5	

Draw the graph, using a scale of 2 cm for x and 1 cm for y . Find:(a) the gradient of the tangent to the curve at $x = -2.5$,(b) the maximum value of y ,(c) the value of x at which this maximum value occurs.

19. Draw the graph of $y = \frac{x}{x^2+1}$, for $-6 \leq x \leq 6$.

(Scales: 1 cm for x , 10 cm for y)

20. Draw the graph of $E = \frac{5000}{x} + 3x$ for

$10 \leq x \leq 80$. (Scales: 1 cm to 5 units for x and 1 cm to 25 units for E)

From the graph find:

- the minimum value of E ,
- the value of x corresponding to this minimum value,
- the range of values of x for which E is less than 275.

Sketch graphs

You need to recognise and be able to sketch the graphs of:

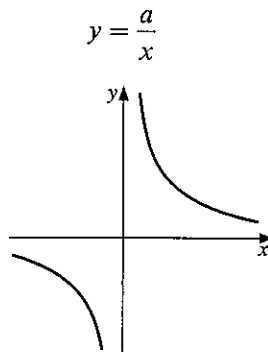

It discontinues
at $x = 0$.
 $x = 0$ is an asymptote.

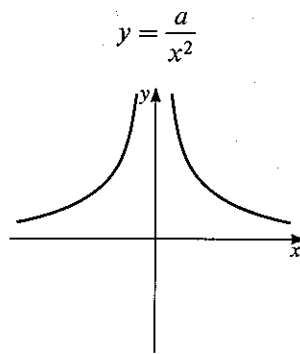

It discontinues
at $x = 0$.
 $x = 0$ is an asymptote.

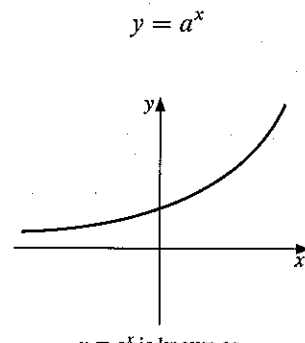

$y = a^x$ is known as
an *exponential*
function.

Exercise 8

- A rectangle has a perimeter of 14 cm and length x cm. Show that the width of the rectangle is $(7 - x)$ cm and hence that the area A of the rectangle is given by the formula $A = x(7 - x)$. Draw the graph, plotting x on the horizontal axis with a scale of 2 cm to 1 unit, and A on the vertical axis with a scale of 1 cm to 1 unit. Take x from 0 to 7. From the graph find:
 - the area of the rectangle when $x = 2.25$ cm,
 - the dimensions of the rectangle when its area is 9 cm^2 ,
 - the maximum area of the rectangle,
 - the length and width of the rectangle corresponding to the maximum area,
 - what shape of rectangle has the largest area.
- A farmer has 60 m of wire fencing which he uses to make a rectangular pen for his sheep. He uses a stone wall as one side of the pen so the wire is used for only 3 sides of the pen.

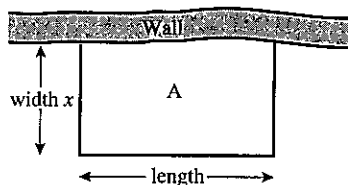

If the width of the pen is x m, what is the length (in terms of x)?

What is the area A of the pen?

Draw a graph with area A on the vertical axis and the width x on the horizontal axis. Take values of x from 0 to 30.

What dimensions should the pen have if the farmer wants to enclose the largest possible area?

3. A ball is thrown in the air so that t seconds after it is thrown, its height h metres above its starting point is given by the function $h = 25t - 5t^2$. Draw the graph of the function for $0 \leq t \leq 6$, plotting t on the horizontal axis with a scale of 2 cm to 1 second, and h on the vertical axis with a scale of 2 cm for 10 metres. Use the graph to find:
- the time when the ball is at its greatest height,
 - the greatest height reached by the ball,
 - the interval of time during which the ball is at a height of more than 30 m.

4. The velocity v m/s of a missile t seconds after launching is given by the equation $v = 54t - 2t^3$. Draw a graph, plotting t on the horizontal axis with a scale of 2 cm to 1 second, and v on the vertical axis with a scale of 1 cm for 10 m/s. Take values of t from 0 to 5.

Use the graph to find:

- the maximum velocity reached,
 - the time taken to accelerate to a velocity of 70 m/s,
 - the interval of time during which the missile is travelling at more than 100 m/s.
5. Draw the graph of $y = 2^x$, for $-4 \leq x \leq 4$.
(Scales: 2 cm for x , 1 cm for y)
6. Draw the graph of $y = 3^x$, for $-3 \leq x \leq 3$.
(Scales: 2 cm for x , $\frac{1}{2}$ cm for y)
Find the gradient of the tangent to the curve at $x = 1$.

7. Consider the equation $y = \frac{1}{x}$.

When $x = \frac{1}{2}$, $y = \frac{1}{\frac{1}{2}} = 2$.

When $x = \frac{1}{100}$, $y = \frac{1}{\frac{1}{100}} = 100$.

As the denominator of the fraction $\frac{1}{x}$ gets smaller, the answer gets larger. An 'infinitely small' denominator gives an 'infinitely large' answer.

We write $\frac{1}{0} \rightarrow \infty$. ' $\frac{1}{0}$ tends to an infinitely large number.'

Draw the graph of $y = \frac{1}{x}$ for $x = -4, -3, -2, -1, -0.5, -0.25, 0.5, 1, 2, 3, 4$
(Scales: 2 cm for x and y)

8. Draw the graph of $y = x + \frac{1}{x}$ for $x = -4, -3, -2, -1, -0.5, -0.25, 0.25, 0.5, 1, 2, 3, 4$
(Scales: 2 cm for x and y)

9. Draw the graph of $y = x + \frac{1}{x^2}$ for $x = -4, -3, -2, -1, -0.5, -0.25, 0.25, 0.5, 1, 2, 3, 4$
(Scales: 2 cm for x , 1 cm for y)

10. This sketch shows a water tank with a square base. It is 1.5 m high, and the length of the base is x metres.

(a) Explain why the volume of the tank is given by the formula $V = 1.5x^2$

(b) Complete the table to show the volume for various values of x .

x	0.1	0.2	0.3	0.4	0.5	0.6	0.7	0.8
V	0.02	0.06	0.14	0.24		0.54	0.74	0.96

x	0.9	1.0	1.1	1.2	1.3	1.4	1.5
V	1.2		1.82		2.54		3.38

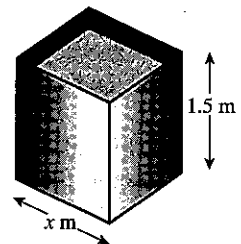

(c) Draw the graph of $V = 1.5x^2$ for values of x from 0 to 1.5.

(d) What value of x will give a volume of 3 m^3 ?

(e) A guest house needs a tank with a volume at least 2 m^3 . To fit the tank into the loft, it must not be more than 1.3 m wide.

Write down the range of values for x which will satisfy these conditions.

7.6 Interpreting graphs

Exercise 9

1. Kendal Motors hire out vans at a basic charge of \$35 plus a charge of 20c per km travelled. Copy and complete the table where x is the number of km travelled and C is the total cost in dollars.

x	0	50	100	150	200	250	300
C	35			65			95

Draw a graph of C against x , using scales of 2 cm for 50 km on the x -axis and 1 cm for \$10 on the C -axis.

- (a) Use the graph to find the number of miles travelled when the total cost was \$71.
 (b) What is the formula connecting C and x ?
2. A car travels along a motorway and the amount of petrol in its tank is monitored as shown on the graph below.
- (a) How much petrol was bought at the first stop?
 (b) What was the petrol consumption in km per litre:
 (i) before the first stop,
 (ii) between the two stops?
 (c) What was the average petrol consumption over the 200 km?

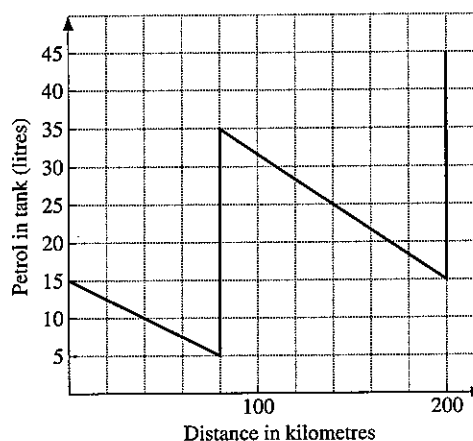

After it leaves the second service station the car encounters road works and slow traffic for the next 20 km. Its petrol consumption is reduced to 4 km per litre. After that, the road clears and the car travels a further 75 km during which time the consumption is 7.5 km/litre. Draw the graph above and extend it to show the next 95 km. How much petrol is in the tank at the end of the journey?

3. A firm makes a profit of P thousand dollars from producing x thousand tiles.

Corresponding values of P and x are given below

x	0	0.5	1.0	1.5	2.0	2.5	3.0
P	-1.0	0.75	2.0	2.75	3.0	2.75	2.0

Using a scale of 4 cm to one unit on each axis, draw the graph of P against x . [Plot x on the horizontal axis.] Use your graph to find:

- (a) the number of tiles the firm should produce in order to make the maximum profit.
 (b) the minimum number of tiles that should be produced to cover the cost of production.
 (c) the range of values of x for which the profit is more than \$2850.

- 4 A small firm increases its monthly expenditure on advertising and records its monthly income from sales.

Month	1	2	3	4	5	6	7
Expenditure (\$)	100	200	300	400	500	600	700
Income (\$)	280	450	560	630	680	720	740

Draw a graph to display this information.

- (a) Is it wise to spend \$100 per month on advertising?
 (b) Is it wise to spend \$700 per month?
 (c) What is the most sensible level of expenditure on advertising?

7.7 Graphical solution of equations

Accurately drawn graphs enable us to find approximate solutions to a wide range of equations, many of which are impossible to solve exactly by 'conventional' methods.

Example 1

Draw the graph of the function

$$y = 2x^2 - x - 3$$

for $-2 \leq x \leq 3$. Use the graph to find approximate solutions to the following equations.

- (a) $2x^2 - x - 3 = 6$
 (b) $2x^2 - x = x + 5$

The table of values for $y = 2x^2 - x - 3$ is found. Note the 'extra' value at $x = \frac{1}{2}$.

x	-2	-1	0	1	2	3	$\frac{1}{2}$
$2x^2$	8	2	0	2	8	18	$\frac{1}{2}$
$-x$	2	1	0	-1	-2	-3	$-\frac{1}{2}$
-3	-3	-3	-3	-3	-3	-3	-3
y	7	0	-3	-2	3	12	-3

The graph drawn from this table is opposite.

- (a) To solve the equation $2x^2 - x - 3 = 6$, the line $y = 6$ is drawn. At the points of intersection (A and B), y simultaneously equals both 6 and $(2x^2 - x - 3)$.

So we may write

$$2x^2 - x - 3 = 6$$

The solutions are the x -values of the points A and B.

i.e. $x = -1.9$ and $x = 2.4$ approx.

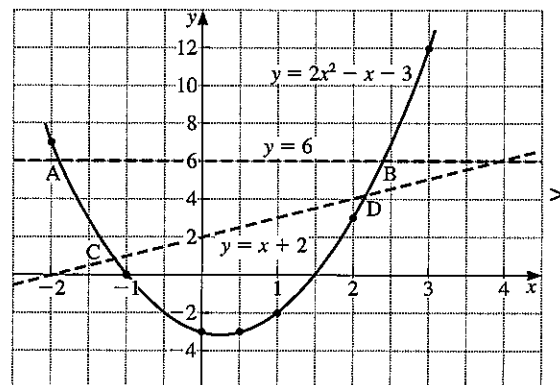

- (b) To solve the equation $2x^2 - x = x + 5$, we rearrange the equation to obtain the function $(2x^2 - x - 3)$ on the left-hand side. In this case, subtract 3 from both sides.

$$\begin{aligned} 2x^2 - x - 3 &= x + 5 - 3 \\ 2x^2 - x - 3 &= x + 2 \end{aligned}$$

If we now draw the line $y = x + 2$, the solutions of the equation are given by the x -values of C and D, the points of intersection. i.e. $x = -1.2$ and $x = 2.2$ approx.

It is important to rearrange the equation to be solved so that the function already plotted is on one side.

Example 2

Assuming that the graph of $y = x^2 - 3x + 1$ has been drawn, find the equation of the line which should be drawn to solve the equation:

$$x^2 - 4x + 3 = 0$$

Rearrange $x^2 - 4x + 3 = 0$ in order to obtain $(x^2 - 3x + 1)$ on the left-hand side.

$$\begin{array}{l} \phantom{\text{add } x} \quad x^2 - 4x + 3 = 0 \\ \text{add } x \quad \quad x^2 - 3x + 3 = x \\ \text{subtract } 2 \quad x^2 - 3x + 1 = x - 2 \end{array}$$

Therefore draw the line $y = x - 2$ to solve the equation.

Exercise 10

- In the diagram, the graph of $y = x^2 - 2x - 3$, $y = -2$ and $y = x$ have been drawn. Use the graphs to find approximate solutions to the following equations:
 - $x^2 - 2x - 3 = -2$
 - $x^2 - 2x - 3 = x$
 - $x^2 - 2x - 3 = 0$
 - $x^2 - 2x - 1 = 0$

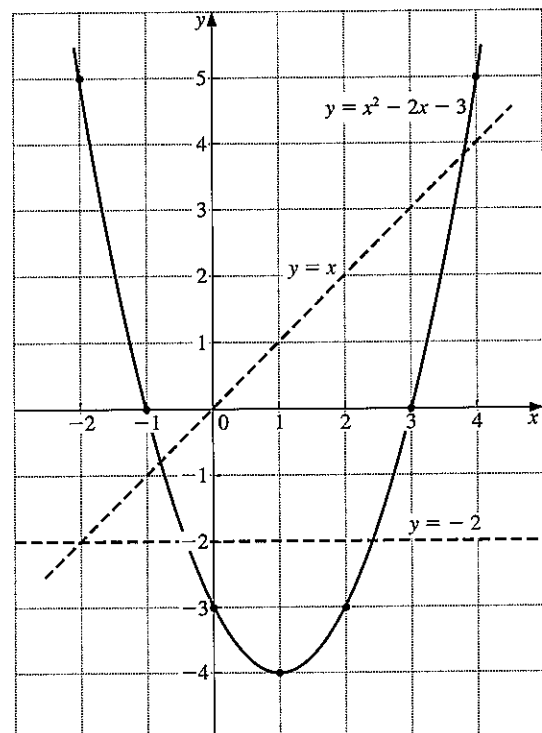

In questions 2 to 4, use a scale of 2 cm to 1 unit for x and 1 cm to 1 unit for y .

2. Draw the graphs of the functions $y = x^2 - 2x$ and $y = x + 1$ for $-1 \leq x \leq 4$. Hence find approximate solutions of the equation $x^2 - 2x = x + 1$.
3. Draw the graphs of the functions $y = x^2 - 3x + 5$ and $y = x + 3$ for $-1 \leq x \leq 5$. Hence find approximate solutions of the equation $x^2 - 3x + 5 = x + 3$.
4. Draw the graphs of the functions $y = 6x - x^2$ and $y = 2x + 1$ for $0 \leq x \leq 5$. Hence find approximate solutions of the equation $6x - x^2 = 2x + 1$.

In questions 5 to 9, do *not* draw any graphs.

5. Assuming the graph of $y = x^2 - 5x$ has been drawn, find the equation of the line which should be drawn to solve the equations:

(a) $x^2 - 5x = 3$	(b) $x^2 - 5x = -2$
(c) $x^2 - 5x = x + 4$	(d) $x^2 - 6x = 0$
(e) $x^2 - 5x - 6 = 0$	
6. Assuming the graph of $y = x^2 + x + 1$ has been drawn, find the equation of the line which should be drawn to solve the equations:

(a) $x^2 + x + 1 = 6$	(b) $x^2 + x + 1 = 0$
(c) $x^2 + x - 3 = 0$	(d) $x^2 - x + 1 = 0$
(e) $x^2 - x - 3 = 0$	
7. Assuming the graph of $y = 6x - x^2$ has been drawn, find the equation of the line which should be drawn to solve the equations:

(a) $4 + 6x - x^2 = 0$	(b) $4x - x^2 = 0$
(c) $2 + 5x - x^2 = 0$	(d) $x^2 - 6x = 3$
(e) $x^2 - 6x = -2$	
8. Assuming the graph of $y = x + \frac{4}{x}$ has been drawn, find the equation of the line which should be drawn to solve the equations:

(a) $x + \frac{4}{x} - 5 = 0$	(b) $\frac{4}{x} - x = 0$
(c) $x + \frac{4}{x} = 0.2$	(d) $2x + \frac{4}{x} - 3 = 0$
(e) $x^2 + 4 = 3x$	
9. Assuming the graph of $y = x^2 - 8x - 7$ has been drawn, find the equation of the line which should be drawn to solve the equations:

(a) $x = 8 + \frac{7}{x}$	(b) $2x^2 = 16x + 9$
(c) $x^2 = 7$	(d) $x = \frac{4}{x - 8}$
(e) $2x - 5 = \frac{14}{x}$	

For questions 10 to 14, use scales of 2 cm to 1 unit for x and 1 cm to 1 unit for y .

10. Draw the graph of $y = x^2 - 2x + 2$ for $-2 \leq x \leq 4$. By drawing other graphs, solve the equations:
- $x^2 - 2x + 2 = 8$
 - $x^2 - 2x + 2 = 5 - x$
 - $x^2 - 2x - 5 = 0$
11. Draw the graph of $y = x^2 - 7x$ for $0 \leq x \leq 7$. Draw suitable straight lines to solve the equations:
- $x^2 - 7x + 9 = 0$
 - $x^2 - 5x + 1 = 0$
12. Draw the graph of $y = x^2 + 4x + 5$ for $-6 \leq x \leq 1$. Draw suitable straight lines to find approximate solutions of the equations:
- $x^2 + 3x - 1 = 0$
 - $x^2 + 5x + 2 = 0$
13. Draw the graph of $y = 2x^2 + 3x - 9$ for $-3 \leq x \leq 2$. Draw suitable straight lines to find approximate solutions of the equations:
- $2x^2 + 3x - 4 = 0$
 - $2x^2 + 2x - 9 = 1$
14. Draw the graph of $y = 2 + 3x - 2x^2$ for $-2 \leq x \leq 4$.
- Draw suitable straight lines to find approximate solutions of the equations:
 - $2 + 4x - 2x^2 = 0$
 - $2x^2 - 3x - 2 = 0$
 - Find the range of values of x for which $2 + 3x - 2x^2 \geq -5$.
15. Draw the graph of $y = \frac{18}{x}$ for $1 \leq x \leq 10$, using scales of 1 cm to one unit on both axes. Use the graph to solve approximately:
- $\frac{18}{x} = x + 2$
 - $\frac{18}{x} + x = 10$
 - $x^2 = 18$
16. Draw the graph of $y = \frac{1}{2}x^2 - 6$ for $-4 \leq x \leq 4$, taking 2 cm to 1 unit on each axis.
- Use your graph to solve approximately the equation $\frac{1}{2}x^2 - 6 = 1$.
 - Using tables or a calculator confirm that your solutions are approximately $\pm\sqrt{14}$ and explain why this is so.
 - Use your graph to find the square roots of 8.
17. Draw the graph of $y = 6 - 2x - \frac{1}{2}x^3$ for $x = \pm 2, \pm 1\frac{1}{2}, \pm 1, \pm \frac{1}{2}, 0$. Take 4 cm to 1 unit for x and 1 cm to 1 unit for y . Use your graph to find approximate solutions of the equations:
- $\frac{1}{2}x^3 + 2x - 6 = 0$
 - $x - \frac{1}{2}x^3 = 0$
- Using tables confirm that two of the solutions to the equation in part (b) are $\pm\sqrt{2}$ and explain why this is so.

18. Draw the graph of $y = x + \frac{12}{x} - 5$ for $x = 1, 1\frac{1}{2}, 2, 3, 4, 5, 6, 7, 8$, taking 2 cm to 1 unit on each axis.
- (a) From your graph find the range of values of x for which $x + \frac{12}{x} \leq 9$
- (b) Find an approximate solution of the equation $2x - \frac{12}{x} - 12 = 0$.
19. Draw the graph of $y = 2^x$ for $-4 \leq x \leq 4$, taking 2 cm to one unit for x and 1 cm to one unit for y . Find approximate solutions to the equations:
- (a) $2^x = 6$ (b) $2^x = 3x$ (c) $x2^x = 1$
- Find also the approximate value of $2^{2.5}$.
20. Draw the graph of $y = \frac{1}{x}$ for $-4 \leq x \leq 4$ taking 2 cm to one unit on each axis. Find approximate solutions to the equations:
- (a) $\frac{1}{x} = x + 1$
- (b) $2x^2 - x - 1 = 0$

7.8 Distance-time graphs

When a distance-time graph is drawn the *gradient* of the graph gives the *speed* of the object.

From O to A : constant speed

A to B : speed goes down to zero

B to C : at rest

C to D : accelerates

D to E : constant speed (not as fast as O to A)

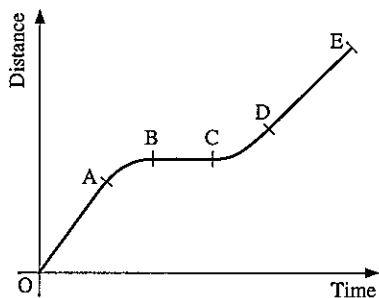

Exercise 11

1. The graph shows the journeys made by a van and a car starting at York, travelling to Durham and returning to York.
 - (a) For how long was the van stationary during the journey?
 - (b) At what time did the car first overtake the van?
 - (c) At what speed was the van travelling between 09:30 and 10:00?
 - (d) What was the greatest speed attained by the car during the entire journey?
 - (e) What was the average speed of the car over its entire journey?

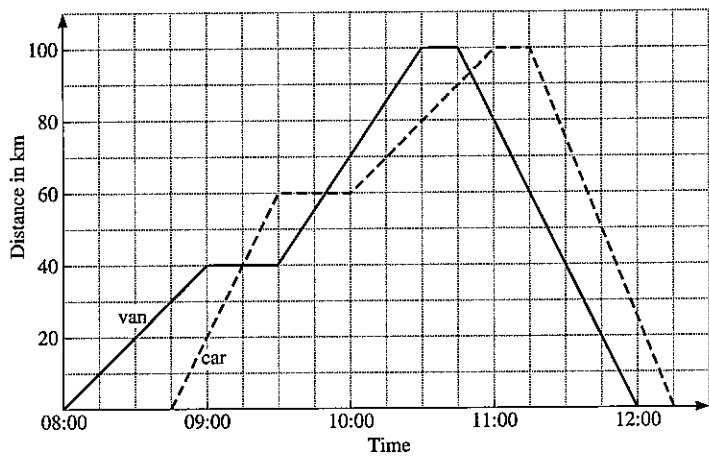

2. The graph shows the journeys of a bus and a car along the same road. The bus goes from Leeds to Darlington and back to Leeds. The car goes from Darlington to Leeds and back to Darlington.
 - (a) When did the bus and the car meet for the second time?
 - (b) At what speed did the car travel from Darlington to Leeds?
 - (c) What was the average speed of the bus over its entire journey?
 - (d) Approximately how far apart were the bus and the car at 09:45?
 - (e) What was the greatest speed attained by the car during its entire journey?

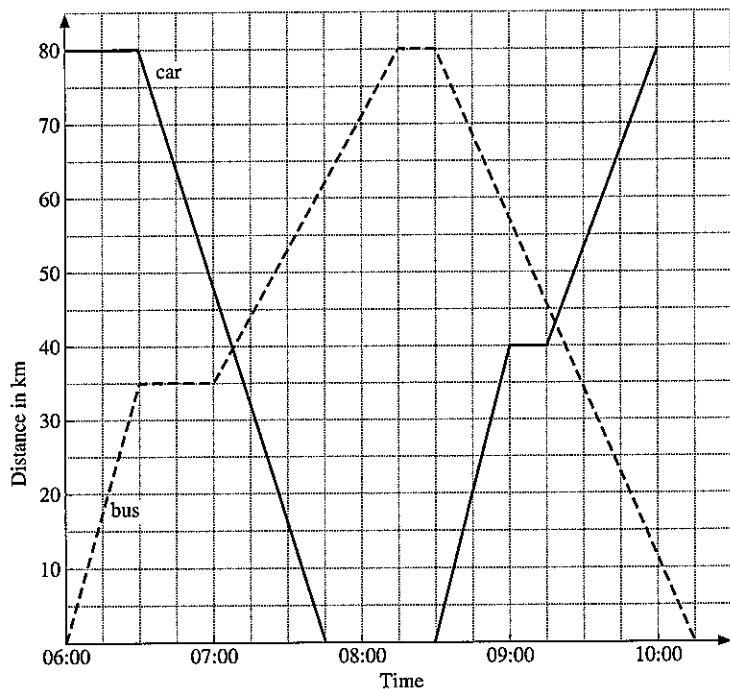

In questions 3, 4, 5 draw a travel graph to illustrate the journey described. Draw axes with the same scales as in question 2.

3. Mrs Chuong leaves home at 08:00 and drives at a speed of 50 km/h. After $\frac{1}{2}$ hour she reduces her speed to 40 km/h and continues at this speed until 09:30. She stops from 09:30 until 10:00 and then returns home at a speed of 60 km/h. Use the graph to find the approximate time at which she arrives home.

4. Mr Coe leaves home at 09:00 and drives at a speed of 20 km/h. After $\frac{3}{4}$ hour he increases his speed to 45 km/h and continues at this speed until 10:45. He stops from 10:45 until 11:30 and then returns home at a speed of 50 km/h. Draw a graph and use it to find the approximate time at which he arrives home.
5. At 10:00 Akram leaves home and cycles to his grandparents' house which is 70 km away. He cycles at a speed of 20 km/h until 11:15, at which time he stops for $\frac{1}{2}$ hour. He then completes the journey at a speed of 30 km/h. At 11:45 Akram's sister, Hameeda, leaves home and drives her car at 60 km/h. Hameeda also goes to her grandparents' house and uses the same road as Akram. At approximately what time does Hameeda overtake Akram?
6. A boat can travel at a speed of 20 km/h in still water. The current in a river flows at 5 km/h so that downstream the boat travels at 25 km/h and upstream it travels at only 15 km/h.

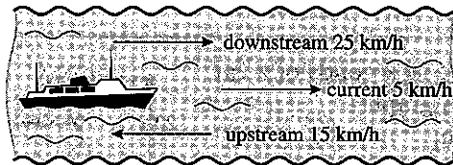

- The boat has only enough fuel to last 3 hours. The boat leaves its base and travels downstream. Draw a distance-time graph and draw lines to indicate the outward and return journeys. After what time must the boat turn round so that it can get back to base without running out of fuel?
7. The boat in question 6 sails in a river where the current is 10 km/h and it has fuel for four hours. At what time must the boat turn round this time if it is not to run out of fuel?
8. The graph shows the motion of three cars A, B and C along the same road. Answer the following questions giving estimates where necessary.
- Which car is in front after
 - 10 s, (ii) 20 s?
 - When is B in the front?
 - When are B and C going at the same speed?
 - When are A and C going at the same speed?
 - Which car is going fastest after 5 s?
 - Which car starts slowly and then goes faster and faster?

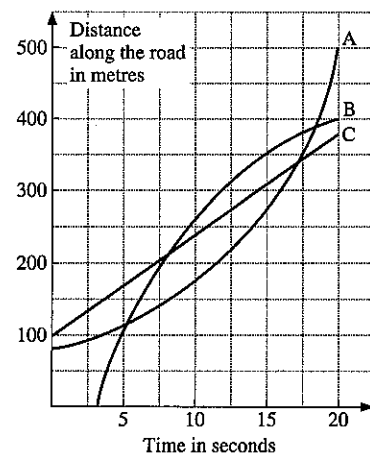

9. Three girls Hanna, Fateema and Carine took part in an egg and spoon race. Describe what happened, giving as many details as possible.

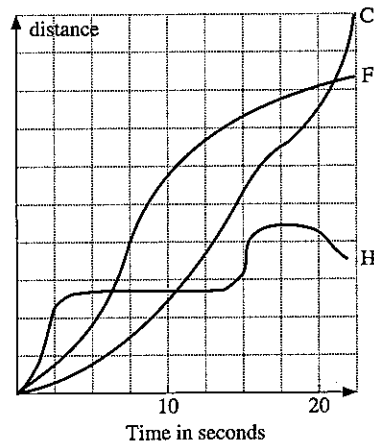

7.9 Speed-time graphs

The diagram is the speed-time graph of the first 30 seconds of a car journey. Two quantities are obtained from such graphs:

- (a) acceleration = gradient of speed-time graph,
 (b) distance travelled = area under graph.

In this example,

- (a) The gradient of line OA = $\frac{20}{10} = 2$

\therefore The acceleration in the first 10 seconds is 2 m/s^2 .

- (b) The distance travelled in the first 30 seconds is given by the area of OAD plus the area of ABCD.

$$\begin{aligned} \text{Distance} &= \left(\frac{1}{2} \times 10 \times 20\right) + (20 \times 20) \\ &= 500 \text{ m} \end{aligned}$$

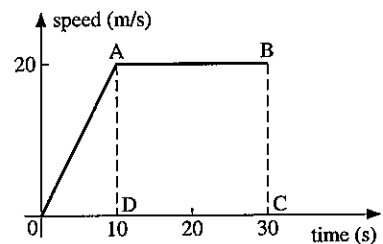

Exercise 12

On the graphs in this exercise speeds are in m/s and all times are in seconds.

1. Find:

- (a) the acceleration when $t = 4$,
 (b) the total distance travelled,
 (c) the average speed for the whole journey.

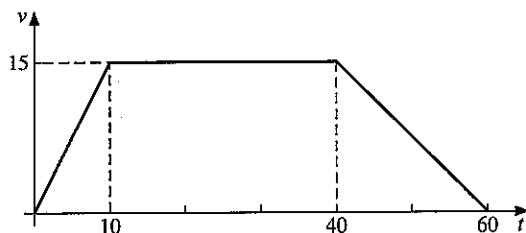

2. Find:

- (a) the total distance travelled,
- (b) the average speed for the whole journey,
- (c) the distance travelled in the first 10 seconds,
- (d) the acceleration when $t = 20$.

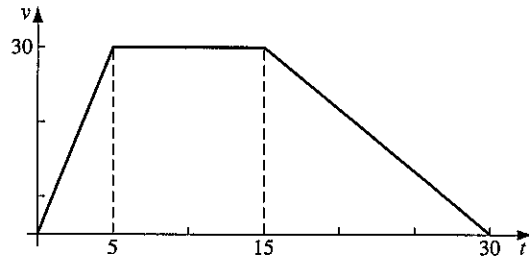

3 Find:

- (a) the total distance travelled,
- (b) the distance travelled in the first 40 seconds,
- (c) the acceleration when $t = 15$.

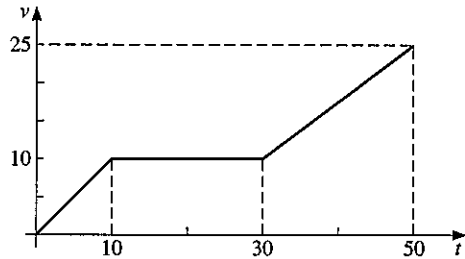

4. Find:

- (a) V if the total distance travelled is 900 m,
- (b) the distance travelled in the first 60 seconds.

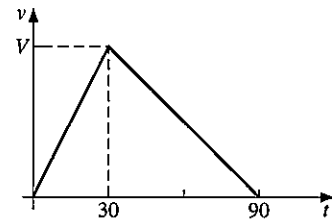

5. Find:

- (a) T if the initial acceleration is 2 m/s^2 ,
- (b) the total distance travelled,
- (c) the average speed for the whole journey.

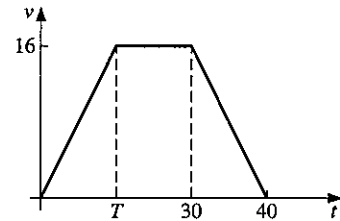

6. Given that the total distance travelled = 810 m, find:

- (a) the value of V ,
- (b) the rate of change of the speed when $t = 30$,
- (c) the time taken to travel the first 420 m of the journey.

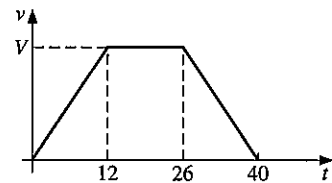

7. Given that the total distance travelled is 1.5 km, find:

- (a) the value of V ,
- (b) the rate of deceleration after 10 seconds.

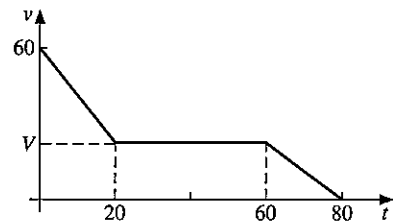

8. Given that the total distance travelled is 1.4 km, and the acceleration is 4 m/s^2 for the first T seconds, find:

- (a) the value of V ,
 (b) the value of T .

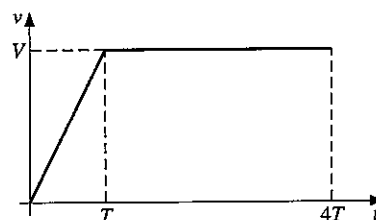

9. Given that the average speed for the whole journey is 37.5 m/s and that the deceleration between T and $2T$ is 2.5 m/s^2 , find:

- (a) the value of V ,
 (b) the value of T .

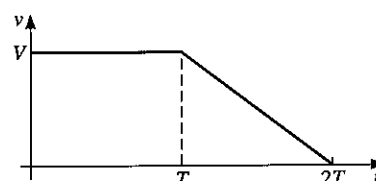

10. Given that the total distance travelled is 4 km and that the initial deceleration is 4 m/s^2 , find:

- (a) the value of V ,
 (b) the value of T .

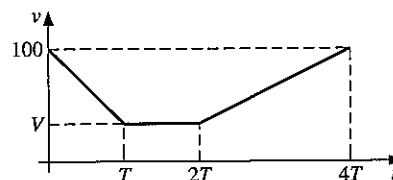

Exercise 13

Sketch a speed–time graph for each question.

All accelerations are taken to be uniform.

1. A car accelerated from 0 to 50 m/s in 9s. How far did it travel in this time?
2. A motor cycle accelerated from 10 m/s to 30 m/s in 6s. How far did it travel in this time?
3. A train slowed down from 50 km/h to 10 km/h in 2 minutes. How far did it travel in this time?
4. When taking off, an aircraft accelerates from 0 to 100 m/s in a distance of 500 m. How long did it take to travel this distance?
5. An earthworm accelerates from a speed of 0.01 m/s to 0.02 m/s over a distance of 0.9 m. How long did it take?
6. A car travelling at 60 km/h is stopped in 6 seconds. How far does it travel in this time? [Hint: Change 6 seconds into hours.]
7. A car accelerates from 15 km/h to 60 km/h in 3 seconds. How far does it travel in this time?
8. At lift-off a rocket accelerates from 0 to 1000 km/h in just 10s. How far does it travel in this time?
9. A coach accelerated from 0 to 60 km/h in 30s. How many metres did it travel in this time?

10. Hamad was driving a car at 30 m/s when he saw an obstacle 45 m in front of him. It took a reaction time of 0.3 seconds before he could press the brakes and a further 2.5 seconds to stop the car. Did he hit the obstacle?
11. An aircraft is cruising at a speed of 200 m/s. When it lands it must be travelling at a speed of 50 m/s. In the air it can slow down at a rate of 0.2 m/s^2 . On the ground it slows down at a rate of 2 m/s^2 . Draw a velocity–time graph for the aircraft as it reduces its speed from 200 m/s to 50 m/s and then to 0 m/s. How far does it travel in this time?

12. The speed of a train is measured at regular intervals of time from $t = 0$ to $t = 60$ s, as shown below.

t s	0	10	20	30	40	50	60
v m/s	0	10	16	19.7	22.2	23.8	24.7

Draw a speed–time graph to illustrate the motion. Plot t on the horizontal axis with a scale of 1 cm to 5s and plot v on the vertical axis with a scale of 2 cm to 5 m/s.

Use the graph to estimate:

- (a) the acceleration at $t = 10$,
 (b) the distance travelled by the train from $t = 30$ to $t = 60$.

[An approximate value for the area under a curve can be found by splitting the area into several trapeziums.]

13. The speed of a car is measured at regular intervals of time from $t = 0$ to $t = 60$ s, as shown below.

t s	0	10	20	30	40	50	60
v m/s	0	1.3	3.2	6	10.1	16.5	30

Draw a speed–time graph using the same scales as in question 11.

Use the graph to estimate:

- (a) the acceleration at $t = 30$.
 (b) the distance travelled by the car from $t = 20$ to $t = 50$.

Revision exercise 7A

1. Find the equation of the straight line satisfied by the following points:

(a)
$$\begin{array}{l|l} x & 2 \quad 7 \quad 10 \\ \hline y & -5 \quad 0 \quad 3 \end{array}$$

(b)
$$\begin{array}{l|l} x & 1 \quad 2 \quad 3 \\ \hline y & 7 \quad 9 \quad 11 \end{array}$$

(c)
$$\begin{array}{l|l} x & 1 \quad 2 \quad 3 \\ \hline y & 8 \quad 6 \quad 4 \end{array}$$

(d)
$$\begin{array}{l|l} x & 3 \quad 4 \quad 5 \\ \hline y & 2 \quad 2\frac{1}{2} \quad 3 \end{array}$$

2. Find the gradient of the line joining each pair of points.

- (a) (3, 3)(5, 7) (b) (3, -1)(7, 3)
 (c) (-1, 4)(1, -3) (d) (2, 4)(-3, 4)
 (e) (0.5, -3)(0.4, -4)

3. Find the gradient and the intercept on the y -axis for the following lines. Draw a *sketch* graph of each line.

- (a) $y = 2x - 7$ (b) $y = 5 - 4x$
 (c) $2y = x + 8$ (d) $2y = 10 - x$
 (e) $y + 2x = 12$ (f) $2x + 3y = 24$

4. In the diagram, the equations of the lines are $y = 3x$, $y = 6$, $y = 10 - x$ and $y = \frac{1}{2}x - 3$. Find the equation corresponding to each line.

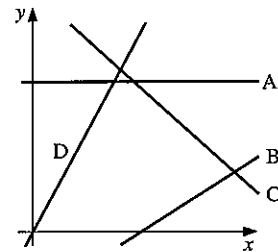

5. In the diagram, the equations of the lines are $2y = x - 8$, $2y + x = 8$, $4y = 3x - 16$ and $4y + 3x = 16$. Find the equation corresponding to each line.

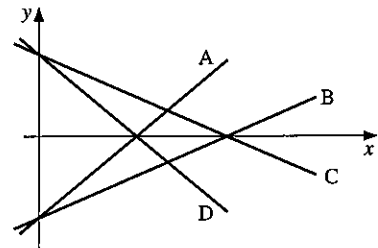

6. Find the equations of the lines which pass through the following pairs of points:

- (a) (2, 1)(4, 5) (b) (0, 4)(-1, 1)
 (c) (2, 8)(-2, 12) (d) (0, 7)(-3, 7)

7. The sketch represents a section of the curve $y = x^2 - 2x - 8$. Calculate:

- (a) the coordinates of A and of B,
 (b) the gradient of the line AB,
 (c) the equation of the straight line AB.

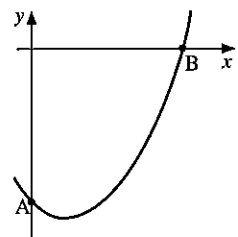

8. Find the area of the triangle formed by the intersection of the lines $y = x$, $x + y = 10$ and $x = 0$.

9. Draw the graph of $y = 7 - 3x - 2x^2$ for $-4 \leq x \leq 2$. Find the gradient of the tangent to the curve at the point where the curve cuts the y -axis.

10. Draw the graph of $y = \frac{4000}{x} + 3x$ for $10 \leq x \leq 80$. Find the minimum value of y .

11. Draw the graph of $y = \frac{1}{x} + 2^x$ for $x = \frac{1}{4}, \frac{1}{2}, \frac{3}{4}, 1, 1\frac{1}{2}, 2, 3$.
12. Assuming that the graph of $y = 4 - x^2$ has been drawn, find the equation of the straight line which should be drawn in order to solve the following equations:
 (a) $4 - 3x - x^2 = 0$ (b) $\frac{1}{2}(4 - x^2) = 0$
 (c) $x^2 - x + 7 = 0$ (d) $\frac{4}{x} - x = 5$
13. Draw the graph of $y = 5 - x^2$ for $-3 \leq x \leq 3$, taking 2 cm to one unit for x and 1 cm to one unit for y .
 Use the graph to find:
 (a) approximate solutions to the equation $4 - x - x^2 = 0$,
 (b) the square roots of 5,
 (c) the square roots of 7.
14. Draw the graph of $y = \frac{5}{x} + 2x - 3$, for $\frac{1}{2} \leq x \leq 7$, taking 2 cm to one unit for x and 1 cm to one unit for y .
 Use the graph to find:
 (a) approximate solutions to the equation $2x^2 - 10x + 7 = 0$,
 (b) the range of values of x for which $\frac{5}{x} + 2x - 3 < 6$.
 (c) the minimum value of y .
15. Draw the graph of $y = 4^x$ for $-2 \leq x \leq 2$.
 Use the graph to find:
 (a) the approximate value of $4^{1.6}$,
 (b) the approximate value of $4^{-\frac{1}{3}}$,
 (c) the gradient of the curve at $x = 0$
 (d) an approximate solution to the equation $4^x = 10$.

16. The diagram is the speed–time graph of a bus.
 Calculate:
 (a) the acceleration during the first 50 seconds,
 (b) the total distance travelled,
 (c) how long it takes before it is moving at 12 m/s for the first time.

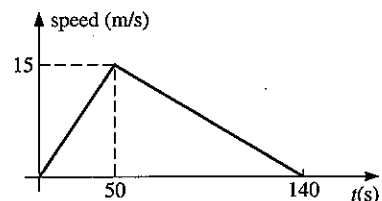

17. The diagram is the speed–time graph of a car.
 Given that the total distance travelled is 2.4 km, calculate:
 (a) the value of the maximum speed V ,
 (b) the distance travelled in the first 30 seconds of the motion.

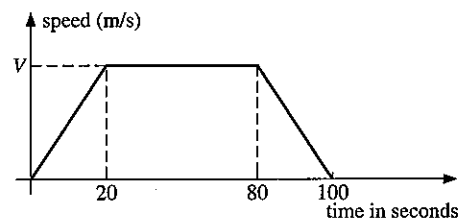

Examination exercise 7B

1. Answer the whole of this question on a sheet of graph paper.

x	0	1	2	3	4	5
y	0	-6	-8	-6	0	10

- (a) Using a scale of 2 cm to represent 1 unit on the x -axis, and a scale of 2 cm to represent 4 units on the y -axis, plot the points given in the table above.
Join the points with a smooth curve.
- (b) (i) On the same grid, draw the line with gradient 2 through the point (3, 0). Label it L.
(ii) Write down the equation of the line L.
(iii) Write down the coordinates of the two points at which the line L meets the curve.
- (c) Draw the tangent to the curve at the point (3, -6) and use it to find an estimate of the gradient of the curve at that point.
- (d) The equation of the curve is $y = ax^2 + bx$, where a and b are integers.
Using some of the values from the table above, calculate a and b .

N 97 4

2. Answer the whole of this question on a sheet of graph paper.

The tables below give values of $f(x)$ and $g(x)$, correct to 1 decimal place.

$$f(x) = \frac{12}{x}$$

$$g(x) = (x - 8)(2 - x)$$

x	2	3	4	5	6	7	8	9	x	2	3	4	5	6	7	8	9
$f(x)$	6	4	3	p	q	1.7	r	1.3	$g(x)$	0	s	8	t	8	5	0	u

- (a) Calculate the values of p , q , r , s , t and u .
- (b) Using a scale of 2 cm to represent 1 unit, draw an x -axis for $0 \leq x \leq 9$ and using a scale of 1 cm to represent 1 unit, draw a y -axis for $-8 \leq y \leq 10$.
Draw the graphs of $y = f(x)$ and $y = g(x)$ for $2 \leq x \leq 9$ on the same grid.
- (c) (i) Show that the equation which is satisfied by the points of intersection of the graphs can be simplified to:
$$x^3 - 10x^2 + 16x + 12 = 0$$

(ii) Write down the two solutions to this equation which can be found from your graphs. Give your answers correct to 1 decimal place.
- (d) Draw the tangent to $y = g(x)$ at the point (7, 5).
Use this to estimate the gradient of the curve $y = g(x)$ at this point.

J 96 4

3. Answer the whole of this question on a sheet of graph paper.

A table of values for $y = \frac{4}{x^2} + x$ is given below.

(The values of y are correct to one decimal place.)

x	-2	-1.5	-1.2	-1	-0.8	1	1.5	2	3	4
y	-1	0.3	1.6	l	5.5	m	3.3	3	n	4.3

- (a) Calculate the values of l , m and n .
- (b) Using a scale of 2 cm to represent 1 unit on both axes, draw the graph of $y = \frac{4}{x^2} + x$ for $-2 \leq x \leq -0.8$ and $1 \leq x \leq 4$.
- (c) Use your graph to solve:
 - (i) $\frac{4}{x^2} + x = 0$
 - (ii) $\frac{4}{x^2} + x = 4$
- (d) By drawing a suitable tangent to the curve, estimate the gradient of the curve when $x = 1.5$. N 98 4

4. Answer the whole of this question on a sheet of graph paper.

A table of values for $y = x(x + 2)(x - 3)$ is given below.

x	-3	-2	-1	0	1	2	3	4
y	a	0	b	0	-6	c	0	24

- (a) Calculate the values of a , b and c .
- (b) Using a scale of 2 cm to represent 1 unit, draw an x -axis for $-3 \leq x \leq 4$ and using a scale of 2 cm to represent 5 units, draw a y -axis for $-20 \leq y \leq 25$. Draw the graph of $y = x(x + 2)(x - 3)$.
- (c) Use your graph to solve:
 - (i) $x(x + 2)(x - 3) = 10$
 - (ii) $x(x + 2)(x - 3) + 15 = 0$
- (d) Draw the line $y = 2x - 6$ on your graph.
- (e) The graphs meet when $x(x + 2)(x - 3) = 2x - 6$.
 - (i) Show that this equation can be written as $x^3 - x^2 - 8x + 6 = 0$
 - (ii) Write down the solutions of this equation. J 98 4

5. The graph shows the speed of a car during a five-minute journey.

- (a) For how long does the car travel at a steady speed?
- (b) What is the acceleration of the car during the first half minute?
- (c) Calculate the distance travelled by the car during
 - (i) the first half minute of the journey,
 - (ii) the whole journey. N 96 2

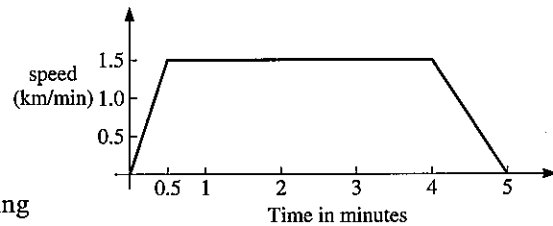

6. A car accelerates steadily from rest to a speed of 20 metres per second in 15 seconds.

(a) Draw the speed–time graph on a copy of the grid below.

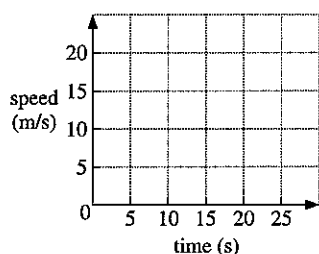

- (b) Calculate the acceleration, in metres per second per second.
 (c) Calculate the distance travelled in these 15 seconds. N 98 2

7. Answer the whole of this question on a sheet of graph paper.

t	0	1	2	3	4	5	6	7
$f(t)$	0	25	37.5	43.8	46.9	48.4	49.2	49.6

- (a) Using a scale of 2 cm to represent 1 unit on the horizontal t -axis and 2 cm to represent 10 units on the y -axis, draw axes for $0 \leq t \leq 7$ and $0 \leq y \leq 60$.
- (b) $f(t) = 50(1 - 2^{-t})$.
- Calculate the value of $f(8)$ and the value of $f(9)$.
 - Estimate the value of $f(t)$ when t is large.
- (c) (i) Draw the tangent to $y = f(t)$ at $t = 2$ and use it to calculate an estimate of the gradient of the curve at this point.
 (ii) The function $f(t)$ represents the speed of a particle at time t . Write down what quantity the gradient gives.
- (d) (i) On the same grid, draw $y = g(t)$ where $g(t) = 6t + 10$, for $0 \leq t \leq 7$.
 (ii) Write down the range of values for t where $f(t) > g(t)$.
 (iii) The function $g(t)$ represents the speed of a second particle at time t . State whether the first or second particle travels the greater distance for $0 \leq t \leq 7$.
 You **must** give a reason for your answer. N 03 4

8 SETS, VECTORS AND FUNCTIONS

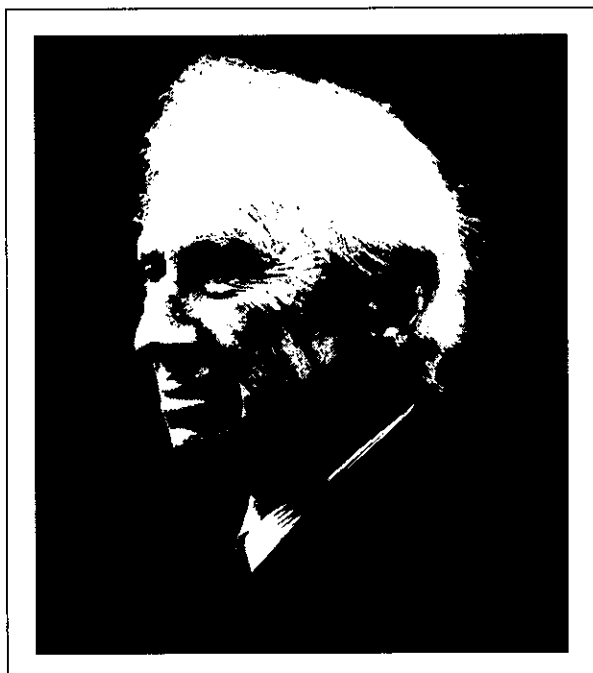

Bertrand Russell (1872–1970) tried to reduce all mathematics to formal logic. He showed that the idea of a set of all sets which are not members of themselves leads to contradictions. He wrote to Gottlieb Frege just as he was putting the finishing touches to a book that represented his life's work, pointing out that Frege's work was invalidated. Russell's elder brother, the second Earl Russell, showed great foresight in 1903 by queuing overnight outside the vehicle licensing office in London to have his car registered as A1.

- 1 Use language, notation and Venn diagrams to describe sets
- 22 Use function notation to describe simple functions, and the notation $f^{-1}(x)$ to describe their inverses; form composite functions
- 35 Add and subtract vectors; multiply a vector by a scalar; calculate the magnitude of a vector; represent vectors by directed line segments; express given vectors in terms of two coplanar vectors; use position vectors

8.1 Sets

1. \cap 'intersection'
 $A \cap B$ is shaded.

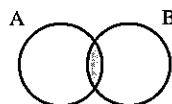

2. \cup 'union'
 $A \cup B$ is shaded.

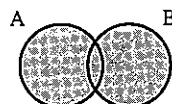

3. \subset 'is a subset of'
 $A \subset B$
 [$B \not\subset A$ means 'B is not a subset of A']

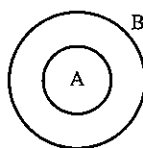

4. \in 'is a member of'
'belongs to'
 $b \in X$

[$e \notin X$ means 'e is not a member of set X']

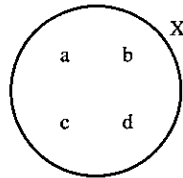

5. \mathcal{E} 'universal set'
 $\mathcal{E} = \{a, b, c, d, e\}$

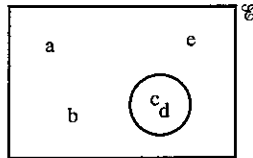

6. A' 'complement of'
'not in A'
 A' is shaded
($A \cup A' = \mathcal{E}$)

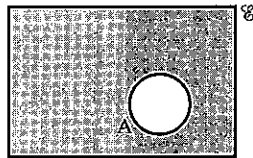

7. $n(A)$ 'the number of elements in set A'
 $n(A) = 3$

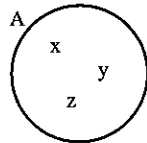

8. $A = \{x : x \text{ is an integer, } 2 \leq x \leq 9\}$

A is the set of elements x such that x is an integer and $2 \leq x \leq 9$.

The set A is $\{2, 3, 4, 5, 6, 7, 8, 9\}$.

9. \emptyset or $\{\}$ 'empty set'
(Note: $\emptyset \subset A$ for any set A)

Exercise 1

1. In the Venn diagram,
 $\mathcal{E} = \{\text{people in an hotel}\}$
 $B = \{\text{people who like bacon}\}$
 $E = \{\text{people who like eggs}\}$

- (a) How many people like bacon?
(b) How many people like eggs but not bacon?
(c) How many people like bacon and eggs?
(d) How many people are in the hotel?
(e) How many people like neither bacon nor eggs?

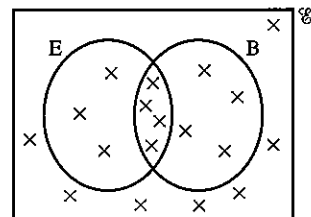

2. In the Venn diagram,

- \mathcal{E} = {boys in the fourth form}
 R = {members of the rugby team}
 C = {members of the cricket team}

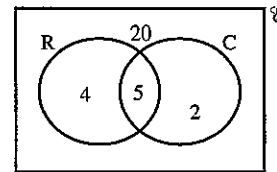

- (a) How many are in the rugby team?
 (b) How many are in both teams?
 (c) How many are in the rugby team but not in the cricket team?
 (d) How many are in neither team?
 (e) How many are there in the fourth form?

3. In the Venn diagram,

- \mathcal{E} = {cars in a street}
 B = {blue cars}
 L = {cars with left-hand drive}
 F = {cars with four doors}

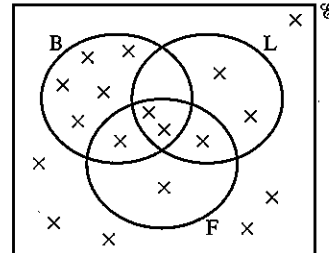

- (a) How many cars are blue?
 (b) How many blue cars have four doors?
 (c) How many cars with left-hand drive have four doors?
 (d) How many blue cars have left-hand drive?
 (e) How many cars are in the street?
 (f) How many blue cars with left-hand drive do not have four doors?

4. In the Venn diagram,

- \mathcal{E} = {houses in the street}
 C = {houses with central heating}
 T = {houses with a colour T.V.}
 G = {houses with a garden}

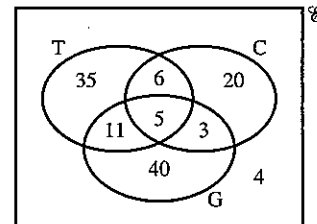

- (a) How many houses have gardens?
 (b) How many houses have a colour T.V. and central heating?
 (c) How many houses have a colour T.V. and central heating and a garden?
 (d) How many houses have a garden but not a T.V. or central heating?
 (e) How many houses have a T.V. and a garden but not central heating?
 (f) How many houses are there in the street?

5. In the Venn diagram,

- \mathcal{E} = {children in a mixed school}
 G = {girls in the school}
 S = {children who can swim}
 L = {children who are left-handed}

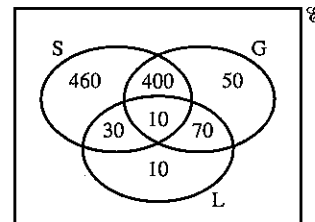

- (a) How many left-handed children are there?
 (b) How many girls cannot swim?
 (c) How many boys can swim?
 (d) How many girls are left-handed?
 (e) How many boys are left-handed?
 (f) How many left-handed girls can swim?
 (g) How many boys are there in the school?

Example

$\mathcal{E} = \{1, 2, 3, \dots, 12\}$, $A = \{2, 3, 4, 5, 6\}$ and $B = \{2, 4, 6, 8, 10\}$.

(a) $A \cup B = \{2, 3, 4, 5, 6, 8, 10\}$

(b) $A \cap B = \{2, 4, 6\}$

(c) $A' = \{1, 7, 8, 9, 10, 11, 12\}$

(d) $n(A \cup B) = 7$

(e) $B' \cap A = \{3, 5\}$

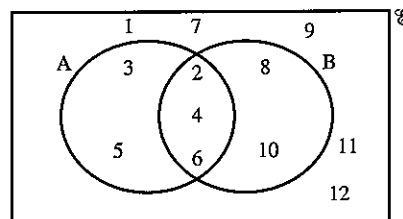
**Exercise 2**

In this exercise, be careful to use set notation only when the answer is a set.

1. If
- $M = \{1, 2, 3, 4, 5, 6, 7, 8\}$
- ,
- $N = \{5, 7, 9, 11, 13\}$
- ,

find:

(a) $M \cap N$ (b) $M \cup N$ (c) $n(N)$ (d) $n(M \cup N)$

State whether true or false:

(e) $5 \in M$

(f) $7 \in (M \cup N)$

(g) $N \subset M$

(h) $\{5, 6, 7\} \subset M$

2. If
- $A = \{2, 3, 5, 7\}$
- ,
- $B = \{1, 2, 3, \dots, 9\}$
- ,

find:

(a) $A \cap B$ (b) $A \cup B$ (c) $n(A \cap B)$ (d) $\{1, 4\} \cap A$

State whether true or false:

(e) $A \in B$

(f) $A \subset B$

(g) $9 \subset B$

(h) $3 \in (A \cap B)$

3. If
- $X = \{1, 2, 3, \dots, 10\}$
- ,
- $Y = \{2, 4, 6, \dots, 20\}$
- and
- $Z = \{x : x \text{ is an integer, } 15 \leq x \leq 25\}$
- ,

find:

(a) $X \cap Y$

(b) $Y \cap Z$

(c) $X \cap Z$

(d) $n(X \cup Y)$

(e) $n(Z)$

(f) $n(X \cup Z)$

State whether true or false:

(g) $5 \in Y$

(h) $20 \in X$

(i) $n(X \cap Y) = 5$

(j) $\{15, 20, 25\} \subset Z$.

4. If
- $D = \{1, 3, 5\}$
- ,
- $E = \{3, 4, 5\}$
- ,
- $F = \{1, 5, 10\}$
- ,

find:

(a) $D \cup E$

(b) $D \cap F$

(c) $n(E \cap F)$

(d) $(D \cup E) \cap F$

(e) $(D \cap E) \cup F$

(f) $n(D \cup F)$

State whether true or false:

(g) $D \subset (E \cup F)$

(h) $3 \in (E \cap F)$

(i) $4 \notin (D \cap E)$

5. Find:

(a) $n(E)$

(b) $n(F)$

(c) $E \cap F$

(d) $E \cup F$

(e) $n(E \cup F)$

(f) $n(E \cap F)$

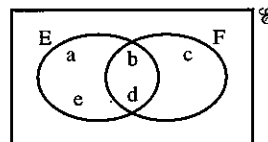

4. Draw eleven diagrams similar to Figure 4 and shade the following sets:

- | | | |
|--------------------------|----------------------------------|--------------------------|
| (a) $A \cap B$ | (b) $A \cup C$ | (c) $A \cap (B \cap C)$ |
| (d) $(A \cup B) \cap C$ | (e) $B \cap (A \cup C)$ | (f) $A \cap B'$ |
| (g) $A \cap (B \cup C)'$ | (h) $(B \cup C) \cap A$ | (i) $C' \cap (A \cap B)$ |
| (j) $(A \cup C) \cup B'$ | (k) $(A \cup C) \cap (B \cap C)$ | |

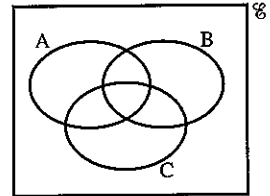

Figure 4

5. Draw nine diagrams similar to Figure 5 and shade the following sets:

- | | | |
|-------------------------|----------------------------------|--------------------------|
| (a) $(A \cup B) \cap C$ | (b) $(A \cap B) \cup C$ | (c) $(A \cup B) \cup C$ |
| (d) $A \cap (B \cup C)$ | (e) $A' \cap C$ | (f) $C' \cap (A \cup B)$ |
| (g) $(A \cap B) \cap C$ | (h) $(A \cap C) \cup (B \cap C)$ | (i) $(A \cup B \cup C)'$ |

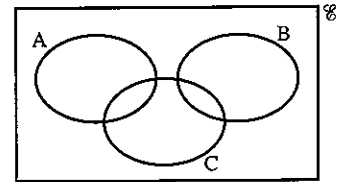
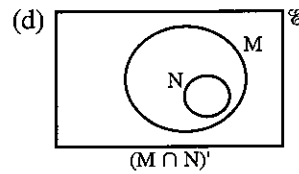
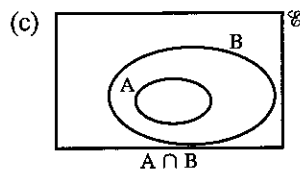
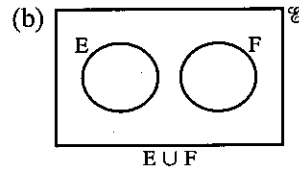
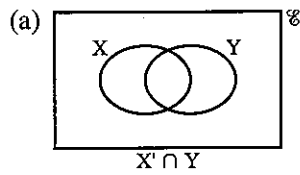
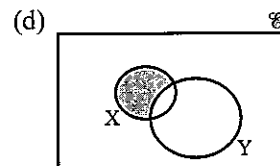
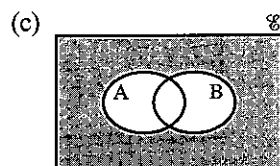
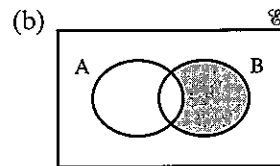
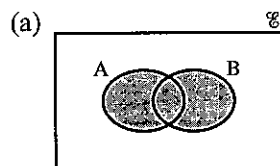

Figure 5

6. Copy each diagram and shade the region indicated.



7. Describe the region shaded.



8.2 Logical problems

Example 1

In a form of 30 girls, 18 play netball and 14 play hockey, whilst 5 play neither. Find the number who play both netball and hockey.

Let $\mathcal{E} = \{\text{girls in the form}\}$
 $N = \{\text{girls who play netball}\}$
 $H = \{\text{girls who play hockey}\}$

and $x = \text{the number of girls who play both netball and hockey}$

The number of girls in each portion of the universal set is shown in the Venn diagram.

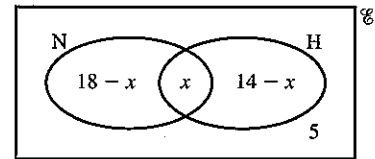

Since $n(\mathcal{E}) = 30$
 $18 - x + x + 14 - x + 5 = 30$
 $37 - x = 30$
 $x = 7$

\therefore Seven girls play both netball and hockey.

Example 2

If $A = \{\text{sheep}\}$
 $B = \{\text{sheep dogs}\}$
 $C = \{\text{'intelligent' animals}\}$
 $D = \{\text{animals which make good pets}\}$

- (a) Express the following sentences in set language:
- No sheep are 'intelligent' animals.
 - All sheep dogs make good pets.
 - Some sheep make good pets.
- (b) Interpret the following statements:
- $B \subset C$
 - $B \cup C = D$
- (a) (i) $A \cap C = \emptyset$
(ii) $B \subset D$
(iii) $A \cap D \neq \emptyset$
- (b) (i) All sheep dogs are intelligent animals.
(ii) Animals which make good pets are either sheep dogs or 'intelligent' animals (or both).

Exercise 4

1. In the Venn diagram $n(A) = 10$, $n(B) = 13$, $n(A \cap B) = x$ and $n(A \cup B) = 18$.

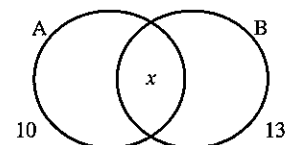

- Write in terms of x the number of elements in A but not in B.
- Write in terms of x the number of elements in B but not in A.
- Add together the number of elements in the three parts of the diagram to obtain the equation $10 - x + x + 13 - x = 18$.
- Hence find the number of elements in both A and B.

2. In the Venn diagram $n(A) = 21$, $n(B) = 17$, $n(A \cap B) = x$ and $n(A \cup B) = 29$.
- (a) Write down in terms of x the number of elements in each part of the diagram.
- (b) Form an equation and hence find x .

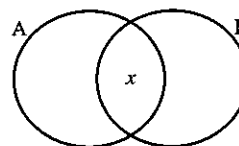

3. The sets M and N intersect such that $n(M) = 31$, $n(N) = 18$ and $n(M \cup N) = 35$. How many elements are in both M and N ?
4. The sets P and Q intersect such that $n(P) = 11$, $n(Q) = 29$ and $n(P \cup Q) = 37$. How many elements are in both P and Q ?
5. The sets A and B intersect such that $n(A \cap B) = 7$, $n(A) = 20$ and $n(B) = 23$. Find $n(A \cup B)$.
6. Twenty boys in a form all play either football or basketball (or both). If thirteen play football and ten play basketball, how many play both sports?
7. Of the 53 staff at a school, 36 drink tea, 18 drink coffee and 10 drink neither tea nor coffee. How many drink both tea and coffee?
8. Of the 32 pupils in a class, 18 play golf, 16 play the piano and 7 play both. How many play neither?
9. Of the pupils in a class, 15 can spell 'parallel', 14 can spell 'Pythagoras', 5 can spell both words and 4 can spell neither. How many pupils are there in the class?
10. In a school, students must take at least one of these subjects: Maths, Physics or Chemistry. In a group of 50 students, 7 take all three subjects, 9 take Physics and Chemistry only, 8 take Maths and Physics only and 5 take Maths and Chemistry only. Of these 50 students, x take Maths only, x take Physics only and $x + 3$ take Chemistry only. Draw a Venn diagram, find x , and hence find the number taking Maths.
11. All of 60 different vitamin pills contain at least one of the vitamins A , B and C . Twelve have A only, 7 have B only, and 11 have C only. If 6 have all three vitamins and there are x having A and B only, B and C only and A and C only, how many pills contain vitamin A ?
12. The IGCSE results of the 30 members of a Rugby squad were as follows: All 30 players passed at least two subjects, 18 players passed at least three subjects, and 3 players passed four subjects or more. Calculate:
- (a) how many passed exactly two subjects,
- (b) what fraction of the squad passed exactly three subjects.
13. In a group of 59 people, some are wearing hats, gloves or scarves (or a combination of these), 4 are wearing all three, 7 are wearing just a hat and gloves, 3 are wearing just gloves and a scarf and 9 are wearing just a hat and scarf. The number wearing only a hat or only gloves is x , and the number wearing only a scarf or none of the three items is $(x - 2)$. Find x and hence the number of people wearing a hat.

14. In a street of 150 houses, three different newspapers are delivered: T, G and M. Of these, 40 receive T, 35 receive G, and 60 receive M; 7 receive T and G, 10 receive G and M and 4 receive T and M; 34 receive no paper at all. How many receive all three?
 Note: If '7 receive T and G', this information does not mean 7 receive T and G *only*.

15. If $S = \{\text{Scottish men}\}$, $G = \{\text{good footballers}\}$, express the following statements in words:

- (a) $G \subset S$
 (b) $G \cap S = \emptyset$
 (c) $G \cap S \neq \emptyset$

(Ignore the truth or otherwise of the statements.)

16. Given that $\mathcal{E} = \{\text{pupils in a school}\}$, $B = \{\text{boys}\}$, $H = \{\text{hockey players}\}$, $F = \{\text{football players}\}$, express the following in words:

- (a) $F \subset B$ (b) $H \subset B'$ (c) $F \cap H \neq \emptyset$ (d) $B \cap H = \emptyset$

Express in set notation:

- (e) No boys play football.
 (f) All pupils play either football or hockey.

17. If $\mathcal{E} = \{\text{living creatures}\}$, $S = \{\text{spiders}\}$, $F = \{\text{animals that fly}\}$, $T = \{\text{animals which taste nice}\}$, express in set notation:

- (a) No spiders taste nice.
 (b) All animals that fly taste nice.
 (c) Some spiders can fly.

Express in words:

- (d) $S \cup F \cup T = \mathcal{E}$ (e) $T \subset S$

18. $\mathcal{E} = \{\text{tigers}\}$, $T = \{\text{tigers who believe in fairies}\}$, $X = \{\text{tigers who believe in Eskimos}\}$, $H = \{\text{tigers in hospital}\}$.

Express in words:

- (a) $T \subset X$ (b) $T \cup X = H$ (c) $H \cap X = \emptyset$

Express in set notation:

- (d) All tigers in hospital believe in fairies.
 (e) Some tigers believe in both fairies and Eskimos.

19. $\mathcal{E} = \{\text{school teachers}\}$, $P = \{\text{teachers called Peter}\}$, $B = \{\text{good bridge players}\}$, $W = \{\text{women teachers}\}$. Express in words:

- (a) $P \cap B = \emptyset$ (b) $P \cup B \cup W = \mathcal{E}$ (c) $P \cap W \neq \emptyset$

Express in set notation:

- (d) Women teachers cannot play bridge well.
 (e) All good bridge players are women called Peter.

8.3 Vectors

A vector quantity has both magnitude and direction. Problems involving forces, velocities and displacements are often made easier when vectors are used.

Addition of vectors

Vectors \mathbf{a} and \mathbf{b} represented by the line segments can be added using the parallelogram rule or the 'nose-to-tail' method.

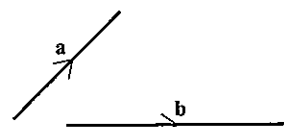

The 'tail' of vector \mathbf{b} is joined to the 'nose' of vector \mathbf{a} .

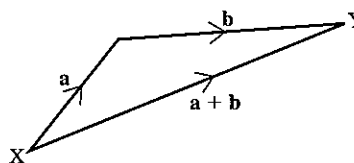

Alternatively the tail of \mathbf{a} can be joined to the 'nose' of vector \mathbf{b} .

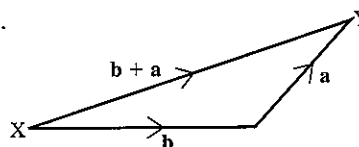

In both cases the vector \overrightarrow{XY} has the same length and direction and therefore

$$\mathbf{a} + \mathbf{b} = \mathbf{b} + \mathbf{a}$$

Multiplication by a scalar

A scalar quantity has a magnitude but no direction (e.g. mass, volume, temperature). Ordinary numbers are scalars.

When vector \mathbf{x} is multiplied by 2, the result is $2\mathbf{x}$.

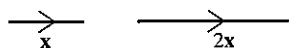

When \mathbf{x} is multiplied by -3 the result is $-3\mathbf{x}$.

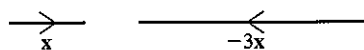

Note:

- (1) The negative sign reverses the direction of the vector.
- (2) The result of $\mathbf{a} - \mathbf{b}$ is $\mathbf{a} + -\mathbf{b}$.
i.e. Subtracting \mathbf{b} is equivalent to adding the negative of \mathbf{b} .

Example

The diagram shows vectors \mathbf{a} and \mathbf{b} .

Find \vec{OP} and \vec{OQ} such that

$$\vec{OP} = 3\mathbf{a} + \mathbf{b}$$

$$\vec{OQ} = -2\mathbf{a} - 3\mathbf{b}$$

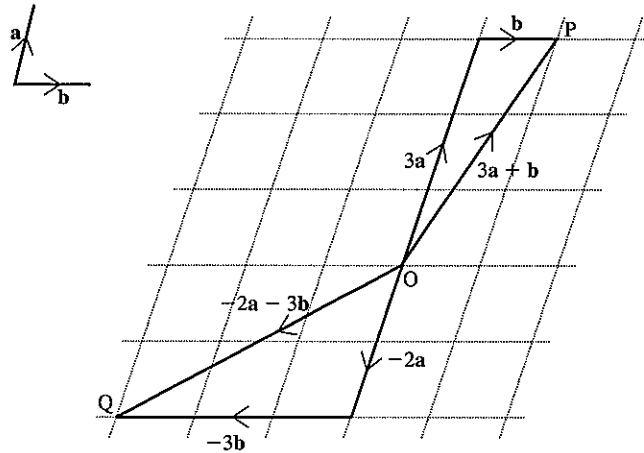

Exercise 5

In questions 1 to 26, use the diagram below to describe the vectors given in terms of \mathbf{c} and \mathbf{d} where $\mathbf{c} = \vec{QN}$ and $\mathbf{d} = \vec{QR}$.

e.g. $\vec{QS} = 2\mathbf{d}$, $\vec{TD} = \mathbf{c} + \mathbf{d}$

- | | | |
|----------------|----------------|----------------|
| 1. \vec{AB} | 2. \vec{SG} | 3. \vec{VK} |
| 4. \vec{KH} | 5. \vec{OT} | 6. \vec{WJ} |
| 7. \vec{FH} | 8. \vec{FT} | 9. \vec{KV} |
| 10. \vec{NQ} | 11. \vec{OM} | 12. \vec{SD} |
| 13. \vec{PI} | 14. \vec{YG} | 15. \vec{OI} |
| 16. \vec{RE} | 17. \vec{XM} | 18. \vec{ZH} |
| 19. \vec{MR} | 20. \vec{KA} | 21. \vec{RZ} |
| 22. \vec{CR} | 23. \vec{NV} | 24. \vec{EV} |
| 25. \vec{JS} | 26. \vec{LE} | |

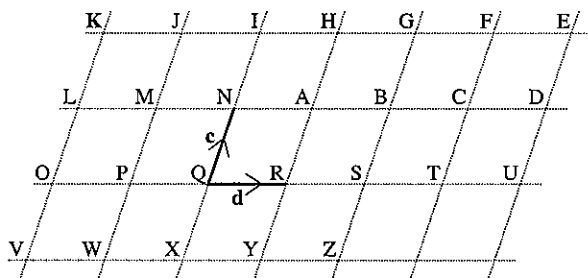

In questions 27 to 38, use the same diagram above to find vectors for the following in terms of the capital letters, starting from Q each time.

e.g. $3\mathbf{d} = \vec{QT}$, $\mathbf{c} + \mathbf{d} = \vec{QA}$.

- | | | | |
|---------------------------------|--------------------------------|---------------------------------|---------------------------------|
| 27. $2\mathbf{c}$ | 28. $4\mathbf{d}$ | 29. $2\mathbf{c} + \mathbf{d}$ | 30. $2\mathbf{d} + \mathbf{c}$ |
| 31. $3\mathbf{d} + 2\mathbf{c}$ | 32. $2\mathbf{c} - \mathbf{d}$ | 33. $-\mathbf{c} + 2\mathbf{d}$ | 34. $\mathbf{c} - 2\mathbf{d}$ |
| 35. $2\mathbf{c} + 4\mathbf{d}$ | 36. $-\mathbf{c}$ | 37. $-\mathbf{c} - \mathbf{d}$ | 38. $2\mathbf{c} - 2\mathbf{d}$ |

In questions 39 to 43, write each vector in terms of \mathbf{a} and/or \mathbf{b} .

39. (a) \vec{BA} (b) \vec{AC}
 (c) \vec{DB} (d) \vec{AD}

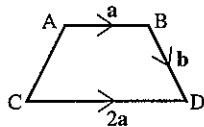

40. (a) \vec{ZX}
 (c) \vec{XY}

- (b) \vec{YW}
 (d) \vec{XZ}

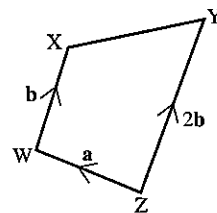

41. (a) \overrightarrow{MK} (b) \overrightarrow{NL} (c) \overrightarrow{NK} (d) \overrightarrow{KN}

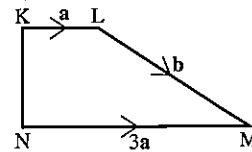

42. (a) \overrightarrow{FE} (b) \overrightarrow{BC} (c) \overrightarrow{FC} (d) \overrightarrow{DA}

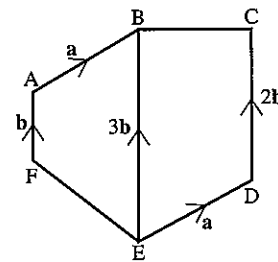

43. (a) \overrightarrow{EC} (b) \overrightarrow{BE} (c) \overrightarrow{AE} (d) \overrightarrow{EA}

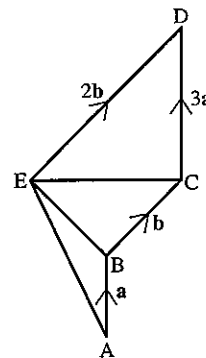

In questions 44 to 46, write each vector in terms of a , b and c .

44. (a) \overrightarrow{FC} (b) \overrightarrow{GB} (c) \overrightarrow{AB} (d) \overrightarrow{HE} (e) \overrightarrow{CA}

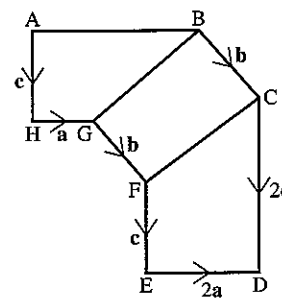

45. (a) \overrightarrow{OF} (b) \overrightarrow{OC} (c) \overrightarrow{BC} (d) \overrightarrow{EB} (e) \overrightarrow{FB}

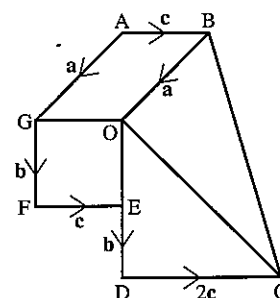

46. (a) \overrightarrow{GD} (b) \overrightarrow{GE} (c) \overrightarrow{AD} (d) \overrightarrow{AF} (e) \overrightarrow{FE}

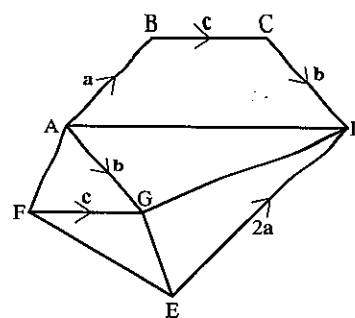

Example

Using Figure 1, express each of the following vectors in terms of **a** and/or **b**.

- (a) \overrightarrow{AP} (b) \overrightarrow{AB} (c) \overrightarrow{OQ} (d) \overrightarrow{PO} (e) \overrightarrow{PQ}
 (f) \overrightarrow{PN} (g) \overrightarrow{ON} (h) \overrightarrow{AN} (i) \overrightarrow{BP} (j) \overrightarrow{QA}

$OA = AP$
 $BQ = 3OB$
 N is the mid-point of PQ
 $\overrightarrow{OA} = \mathbf{a}, \overrightarrow{OB} = \mathbf{b}$

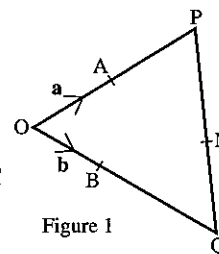

Figure 1

- | | |
|--|--|
| (a) $\overrightarrow{AP} = \mathbf{a}$ | (b) $\overrightarrow{AB} = -\mathbf{a} + \mathbf{b}$ |
| (c) $\overrightarrow{OQ} = 4\mathbf{b}$ | (d) $\overrightarrow{PO} = -2\mathbf{a}$ |
| (e) $\overrightarrow{PQ} = \overrightarrow{PO} + \overrightarrow{OQ}$
$= -2\mathbf{a} + 4\mathbf{b}$ | (f) $\overrightarrow{PN} = \frac{1}{2}\overrightarrow{PQ}$
$= -\mathbf{a} + 2\mathbf{b}$ |
| (g) $\overrightarrow{ON} = \overrightarrow{OP} + \overrightarrow{PN}$
$= 2\mathbf{a} + (-\mathbf{a} + 2\mathbf{b})$
$= \mathbf{a} + 2\mathbf{b}$ | (h) $\overrightarrow{AN} = \overrightarrow{AP} + \overrightarrow{PN}$
$= \mathbf{a} + (-\mathbf{a} + 2\mathbf{b})$
$= 2\mathbf{b}$ |
| (i) $\overrightarrow{BP} = \overrightarrow{BO} + \overrightarrow{OP}$
$= -\mathbf{b} + 2\mathbf{a}$ | (j) $\overrightarrow{QA} = \overrightarrow{QO} + \overrightarrow{OA}$
$= -4\mathbf{b} + \mathbf{a}$ |

Exercise 6

In questions 1 to 6, $\overrightarrow{OA} = \mathbf{a}$ and $\overrightarrow{OB} = \mathbf{b}$. Copy each diagram and use the information given to express the following vectors in terms of **a** and/or **b**.

- (a) \overrightarrow{AP} (b) \overrightarrow{AB} (c) \overrightarrow{OQ} (d) \overrightarrow{PO} (e) \overrightarrow{PQ}
 (f) \overrightarrow{PN} (g) \overrightarrow{ON} (h) \overrightarrow{AN} (i) \overrightarrow{BP} (j) \overrightarrow{QA}

1. A, B and N are mid-points of OP, OQ and PQ respectively.

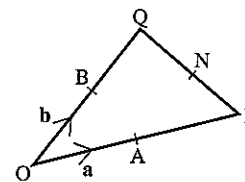

2. A and N are mid-points of OP and PQ and $BQ = 2OB$.

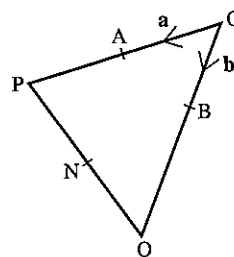

3. $AP = 2OA$, $BQ = OB$, $PN = NQ$.

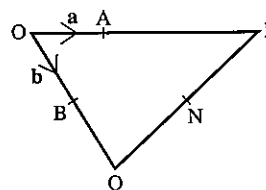

4. $OA = 2AP$, $BQ = 3OB$, $PN = 2NQ$.

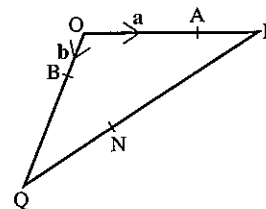

5. $AP = 5OA$, $OB = 2BQ$, $NP = 2QN$.

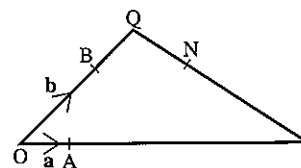

6. $OA = \frac{1}{5}OP$, $OQ = 3OB$, N is $\frac{1}{4}$ of the way along PQ.

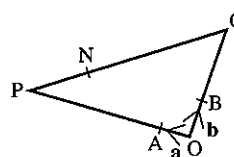

7. In $\triangle XYZ$, the mid-point of YZ is M .
If $\overrightarrow{XY} = \mathbf{s}$ and $\overrightarrow{ZX} = \mathbf{t}$, find \overrightarrow{XM} in terms of \mathbf{s} and \mathbf{t} .

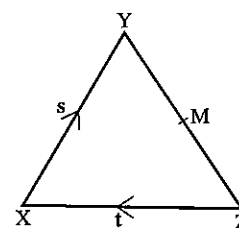

8. In $\triangle AOB$, $AM : MB = 2 : 1$. If $\overrightarrow{OA} = \mathbf{a}$ and $\overrightarrow{OB} = \mathbf{b}$, find \overrightarrow{OM} in terms of \mathbf{a} and \mathbf{b} .

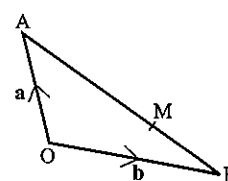

9. O is any point in the plane of the square ABCD.
 The vectors \vec{OA} , \vec{OB} and \vec{OC} are \mathbf{a} , \mathbf{b} and \mathbf{c} respectively. Find the vector \vec{OD} in terms of \mathbf{a} , \mathbf{b} and \mathbf{c} .

10. ABCDEF is a regular hexagon with \vec{AB} representing the vector \mathbf{m}
 \vec{AF} representing the vector \mathbf{n} . Find the vector representing \vec{AD} .

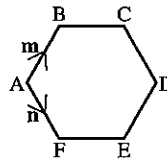

11. ABCDEF is a regular hexagon with centre O.
 $\vec{FA} = \mathbf{a}$ and $\vec{FB} = \mathbf{b}$.
- Express the following vectors in terms of \mathbf{a} and/or \mathbf{b} .
- (a) \vec{AB} (b) \vec{FO} (c) \vec{FC}
 (d) \vec{BC} (e) \vec{AO} (f) \vec{FD}

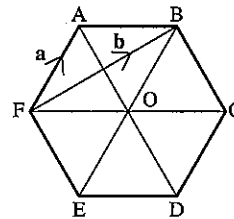

12. In the diagram, M is the mid-point of CD, $BP : PM = 2 : 1$,
 $\vec{AB} = \mathbf{x}$, $\vec{AC} = \mathbf{y}$ and $\vec{AD} = \mathbf{z}$.
- Express the following vectors in terms of \mathbf{x} , \mathbf{y} and \mathbf{z} .
- (a) \vec{DC} (b) \vec{DM} (c) \vec{AM}
 (d) \vec{BM} (e) \vec{BP} (f) \vec{AP}

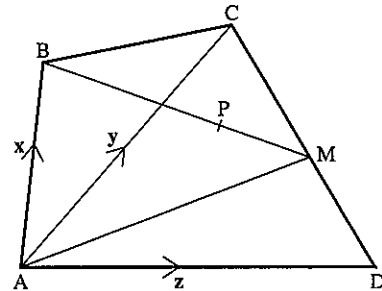

8.4 Column vectors

The vector \vec{AB} may be written as a *column vector*.

$$\vec{AB} = \begin{pmatrix} 5 \\ 3 \end{pmatrix}.$$

The top number is the horizontal component of \vec{AB} (i.e. 5) and the bottom number is the vertical component (i.e. 3).

Similarly $\vec{CD} = \begin{pmatrix} 4 \\ -2 \end{pmatrix}$

$$\vec{EF} = \begin{pmatrix} 0 \\ 6 \end{pmatrix}$$

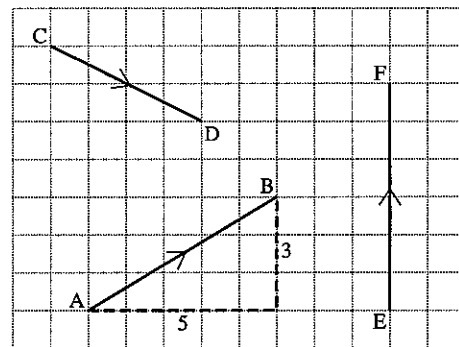

Addition of vectors

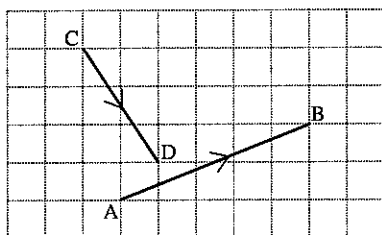

Figure 1

Suppose we wish to add vectors \vec{AB} and \vec{CD} in Figure 1.

First move \vec{CD} so that \vec{AB} and \vec{CD} join 'nose to tail' as in Figure 2. Remember that changing the *position* of a vector does not change the vector. A vector is described by its length and direction.

The broken line shows the result of adding \vec{AB} and \vec{CD} .

In column vectors,

$$\vec{AB} + \vec{CD} = \begin{pmatrix} 5 \\ 2 \end{pmatrix} + \begin{pmatrix} 2 \\ -3 \end{pmatrix}$$

We see that the column vector for the broken line is $\begin{pmatrix} 7 \\ -1 \end{pmatrix}$. So we perform addition with vectors by adding together the corresponding components of the vectors.

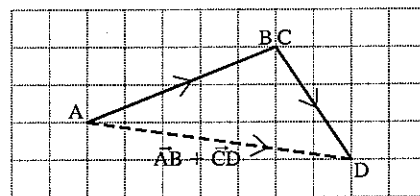

Figure 2

Subtraction of vectors

Figure 3 shows $\vec{AB} - \vec{CD}$.

To subtract vector \vec{CD} from \vec{AB} we *add* the *negative* of \vec{CD} to \vec{AB} .

So $\vec{AB} - \vec{CD} = \vec{AB} + (-\vec{CD})$

In column vectors,

$$\vec{AB} + (-\vec{CD}) = \begin{pmatrix} 5 \\ 2 \end{pmatrix} + \begin{pmatrix} -2 \\ 3 \end{pmatrix} = \begin{pmatrix} 3 \\ 5 \end{pmatrix}$$

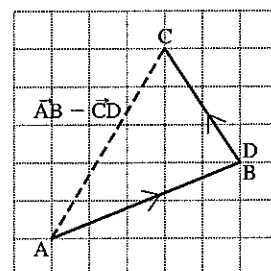

Figure 3

Multiplication by a scalar

If $\mathbf{a} = \begin{pmatrix} 3 \\ -4 \end{pmatrix}$ then $2\mathbf{a} = 2 \begin{pmatrix} 3 \\ -4 \end{pmatrix} = \begin{pmatrix} 6 \\ -8 \end{pmatrix}$.

Each component is multiplied by the number 2.

Parallel vectors

Vectors are parallel if they have the same direction. Both components of one vector must be in the same ratio to the corresponding components of the parallel vector.

e.g. $\begin{pmatrix} 3 \\ -5 \end{pmatrix}$ is parallel to $\begin{pmatrix} 6 \\ -10 \end{pmatrix}$,

because $\begin{pmatrix} 6 \\ -10 \end{pmatrix}$ may be written $2\begin{pmatrix} 3 \\ -5 \end{pmatrix}$.

In general the vector $k\begin{pmatrix} a \\ b \end{pmatrix}$ is parallel to $\begin{pmatrix} a \\ b \end{pmatrix}$.

Exercise 7

Questions 1 to 36 refer to the following vectors.

$$\mathbf{a} = \begin{pmatrix} 3 \\ 4 \end{pmatrix} \quad \mathbf{b} = \begin{pmatrix} 1 \\ 4 \end{pmatrix} \quad \mathbf{c} = \begin{pmatrix} 4 \\ -3 \end{pmatrix} \quad \mathbf{d} = \begin{pmatrix} -1 \\ 1 \end{pmatrix}$$

$$\mathbf{e} = \begin{pmatrix} 5 \\ 12 \end{pmatrix} \quad \mathbf{f} = \begin{pmatrix} 3 \\ -2 \end{pmatrix} \quad \mathbf{g} = \begin{pmatrix} -4 \\ -2 \end{pmatrix} \quad \mathbf{h} = \begin{pmatrix} -12 \\ 5 \end{pmatrix}$$

Draw and label the following vectors on graph paper (take 1 cm to 1 unit).

- | | | | |
|-----------------------------|-----------------------------|-----------------------------|--------------------|
| 1. \mathbf{c} | 2. \mathbf{f} | 3. $2\mathbf{b}$ | 4. $-\mathbf{a}$ |
| 5. $-\mathbf{g}$ | 6. $3\mathbf{a}$ | 7. $\frac{1}{2}\mathbf{e}$ | 8. $5\mathbf{d}$ |
| 9. $-\frac{1}{2}\mathbf{h}$ | 10. $\frac{3}{2}\mathbf{g}$ | 11. $\frac{1}{5}\mathbf{h}$ | 12. $-3\mathbf{b}$ |

Find the following vectors in component form.

- | | | |
|--|---|--|
| 13. $\mathbf{b} + \mathbf{h}$ | 14. $\mathbf{f} + \mathbf{g}$ | 15. $\mathbf{e} - \mathbf{b}$ |
| 16. $\mathbf{a} - \mathbf{d}$ | 17. $\mathbf{g} - \mathbf{h}$ | 18. $2\mathbf{a} + 3\mathbf{c}$ |
| 19. $3\mathbf{f} + 2\mathbf{d}$ | 20. $4\mathbf{g} - 2\mathbf{b}$ | 21. $5\mathbf{a} + \frac{1}{2}\mathbf{g}$ |
| 22. $\mathbf{a} + \mathbf{b} + \mathbf{c}$ | 23. $3\mathbf{f} - \mathbf{a} + \mathbf{c}$ | 24. $\mathbf{c} + 2\mathbf{d} + 3\mathbf{e}$ |

In each of the following, find \mathbf{x} in component form.

- | | | |
|--|--|---|
| 25. $\mathbf{x} + \mathbf{b} = \mathbf{e}$ | 26. $\mathbf{x} + \mathbf{d} = \mathbf{a}$ | 27. $\mathbf{c} + \mathbf{x} = \mathbf{f}$ |
| 28. $\mathbf{x} - \mathbf{g} = \mathbf{h}$ | 29. $2\mathbf{x} + \mathbf{b} = \mathbf{g}$ | 30. $2\mathbf{x} - 3\mathbf{d} = \mathbf{g}$ |
| 31. $2\mathbf{b} = \mathbf{d} - \mathbf{x}$ | 32. $\mathbf{f} - \mathbf{g} = \mathbf{e} - \mathbf{x}$ | 33. $2\mathbf{x} + \mathbf{b} = \mathbf{x} + \mathbf{e}$ |
| 34. $3\mathbf{x} - \mathbf{b} = \mathbf{x} + \mathbf{h}$ | 35. $\mathbf{a} + \mathbf{b} + \mathbf{x} = \mathbf{b} + \mathbf{a}$ | 36. $2\mathbf{x} + \mathbf{e} = \mathbf{0}$ (zero vector) |

37. (a) Draw and label each of the following vectors on graph paper.

$$\mathbf{l} = \begin{pmatrix} -3 \\ -3 \end{pmatrix}; \quad \mathbf{m} = \begin{pmatrix} 2 \\ 0 \end{pmatrix}; \quad \mathbf{n} = \begin{pmatrix} 3 \\ 2 \end{pmatrix}; \quad \mathbf{p} = \begin{pmatrix} 1 \\ -2 \end{pmatrix}; \quad \mathbf{q} = \begin{pmatrix} 3 \\ 0 \end{pmatrix};$$

$$\mathbf{r} = \begin{pmatrix} 6 \\ 4 \end{pmatrix}; \quad \mathbf{s} = \begin{pmatrix} 2 \\ 2 \end{pmatrix}; \quad \mathbf{t} = \begin{pmatrix} 2 \\ -4 \end{pmatrix}; \quad \mathbf{u} = \begin{pmatrix} -1 \\ -3 \end{pmatrix}; \quad \mathbf{v} = \begin{pmatrix} 0 \\ 3 \end{pmatrix}$$

(b) Find four pairs of parallel vectors amongst the ten vectors.

38. State whether 'true' or 'false'.

- (a) $\begin{pmatrix} 3 \\ -1 \end{pmatrix}$ is parallel to $\begin{pmatrix} 9 \\ -3 \end{pmatrix}$ (b) $\begin{pmatrix} -2 \\ 0 \end{pmatrix}$ is parallel to $\begin{pmatrix} 4 \\ 0 \end{pmatrix}$
 (c) $\begin{pmatrix} -1 \\ 1 \end{pmatrix}$ is parallel to $\begin{pmatrix} 1 \\ -1 \end{pmatrix}$ (d) $\begin{pmatrix} -5 \\ -15 \end{pmatrix} = 5\begin{pmatrix} 1 \\ -3 \end{pmatrix}$
 (e) $\begin{pmatrix} 4 \\ 0 \end{pmatrix}$ is parallel to $\begin{pmatrix} 0 \\ 6 \end{pmatrix}$ (f) $\begin{pmatrix} 3 \\ -1 \end{pmatrix} + \begin{pmatrix} -4 \\ -2 \end{pmatrix} = \begin{pmatrix} -1 \\ 1 \end{pmatrix}$

39. (a) Draw a diagram to illustrate the vector addition $\overrightarrow{AB} + \overrightarrow{CD}$.
 (b) Draw a diagram to illustrate $\overrightarrow{AB} - \overrightarrow{CD}$.

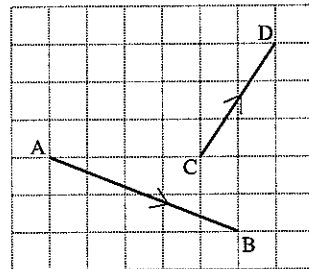

40. Draw separate diagrams to illustrate the following.

- (a) $\overrightarrow{FE} + \overrightarrow{JI}$
 (b) $\overrightarrow{HG} + \overrightarrow{FE}$
 (c) $\overrightarrow{JI} - \overrightarrow{FE}$
 (d) $\overrightarrow{HG} + \overrightarrow{JI}$

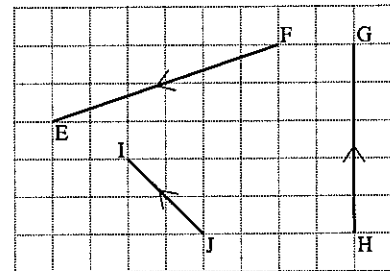

Exercise 8

1. If D has coordinates (7, 2) and E has coordinates (9, 0), find the column vector for \overrightarrow{DE} .
 2. Find the column vector \overrightarrow{XY} where X and Y have coordinates (-1, 4) and (5, 2) respectively.
 3. In the diagram \overrightarrow{AB} represents the vector $\begin{pmatrix} 5 \\ 2 \end{pmatrix}$ and \overrightarrow{BC} represents the vector $\begin{pmatrix} 0 \\ 3 \end{pmatrix}$.
 (a) Copy the diagram and mark point D such that ABCD is a parallelogram.
 (b) Write \overrightarrow{AD} and \overrightarrow{CA} as column vectors.

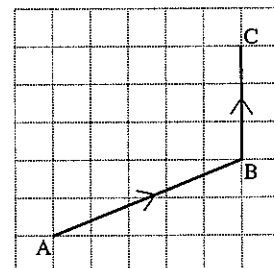

4. (a) On squared paper draw $\overrightarrow{AB} = \begin{pmatrix} 3 \\ -2 \end{pmatrix}$ and $\overrightarrow{BC} = \begin{pmatrix} 4 \\ 2 \end{pmatrix}$ and mark point D such that ABCD is a parallelogram.
 (b) Write \overrightarrow{AD} and \overrightarrow{CA} as column vectors.

5. Copy the diagram in which $\vec{OA} = \begin{pmatrix} 5 \\ 2 \end{pmatrix}$ and $\vec{OB} = \begin{pmatrix} 2 \\ 5 \end{pmatrix}$.

M is the mid-point of AB. Express the following as column vectors:

- (a) \vec{BA} (b) \vec{BM} (c) \vec{OM} (use $\vec{OM} = \vec{OB} + \vec{BM}$)

Hence write down the coordinates of M.

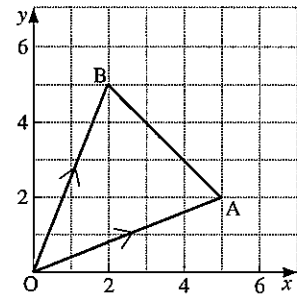

6. On a graph with origin at O, draw $\vec{OA} = \begin{pmatrix} 5 \\ -1 \end{pmatrix}$ and

$\vec{OB} = \begin{pmatrix} 6 \\ -7 \end{pmatrix}$. Given that M is the mid-point of AB express the

following as column vectors:

- (a) \vec{BA} (b) \vec{BM} (c) \vec{OM}

Hence write down the coordinates of M.

7. On a graph with origin at O, draw $\vec{OA} = \begin{pmatrix} -2 \\ 5 \end{pmatrix}$, $\vec{OB} = \begin{pmatrix} 4 \\ 2 \end{pmatrix}$ and $\vec{OC} = \begin{pmatrix} -2 \\ -4 \end{pmatrix}$.

(a) Given that M divides AB such that $AM:MB = 2:1$, express the following as column vectors:

- (i) \vec{BA} (ii) \vec{BM} (iii) \vec{OM}

(b) Given that N divides AC such that $AN:NC = 1:2$, express the following as column vectors:

- (i) \vec{AC} (ii) \vec{AN} (iii) \vec{ON}

8. In square ABCD, side AB has column vector $\begin{pmatrix} 2 \\ 1 \end{pmatrix}$. Find two possible column vectors for \vec{BC} .

9. Rectangle KLMN has an area of 10 square units and \vec{KL} has column vector $\begin{pmatrix} 5 \\ 0 \end{pmatrix}$. Find two possible column vectors for \vec{LM} .

10. In the diagram, ABCD is a trapezium in which $\vec{DC} = 2\vec{AB}$.

If $\vec{AB} = \mathbf{p}$ and $\vec{AD} = \mathbf{q}$ express in terms of \mathbf{p} and \mathbf{q} :

- (a) \vec{BD} (b) \vec{AC} (c) \vec{BC}

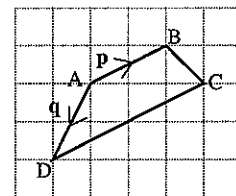

11. Find the image of the vector $\begin{pmatrix} 1 \\ 3 \end{pmatrix}$ after reflection in the following lines:

- (a) $y = 0$ (b) $x = 0$ (c) $y = x$ (d) $y = -x$

Modulus of a vector

The modulus of a vector \mathbf{a} is written $|\mathbf{a}|$ and represents the length (or magnitude) of the vector.

In the diagram above, $\mathbf{a} = \begin{pmatrix} 5 \\ 3 \end{pmatrix}$.

By Pythagoras' Theorem, $|\mathbf{a}| = \sqrt{5^2 + 3^2}$
 $|\mathbf{a}| = \sqrt{34}$ units

In general if $\mathbf{x} = \begin{pmatrix} m \\ n \end{pmatrix}$, $|\mathbf{x}| = \sqrt{m^2 + n^2}$

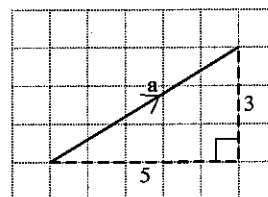

Exercise 9

Questions 1 to 12 refer to the following vectors:

$$\mathbf{a} = \begin{pmatrix} 3 \\ 4 \end{pmatrix} \quad \mathbf{b} = \begin{pmatrix} 4 \\ 1 \end{pmatrix} \quad \mathbf{c} = \begin{pmatrix} 5 \\ 12 \end{pmatrix} \quad \mathbf{d} = \begin{pmatrix} -3 \\ 0 \end{pmatrix}$$

$$\mathbf{e} = \begin{pmatrix} -4 \\ -3 \end{pmatrix} \quad \mathbf{f} = \begin{pmatrix} -3 \\ 6 \end{pmatrix}$$

Find the following, leaving the answer in square root form where necessary.

1. $|\mathbf{a}|$
2. $|\mathbf{b}|$
3. $|\mathbf{c}|$
4. $|\mathbf{d}|$
5. $|\mathbf{e}|$
6. $|\mathbf{f}|$
7. $|\mathbf{a} + \mathbf{b}|$
8. $|\mathbf{c} - \mathbf{d}|$
9. $|2\mathbf{e}|$
10. $|\mathbf{f} + 2\mathbf{b}|$
11. (a) Find $|\mathbf{a} + \mathbf{c}|$. (b) Is $|\mathbf{a} + \mathbf{c}|$ equal to $|\mathbf{a}| + |\mathbf{c}|$?
12. (a) Find $|\mathbf{c} + \mathbf{d}|$. (b) Is $|\mathbf{c} + \mathbf{d}|$ equal to $|\mathbf{c}| + |\mathbf{d}|$?
13. If $\overrightarrow{AB} = \begin{pmatrix} 3 \\ -1 \end{pmatrix}$ and $\overrightarrow{BC} = \begin{pmatrix} 2 \\ 3 \end{pmatrix}$, find $|\overrightarrow{AC}|$.
14. If $\overrightarrow{PQ} = \begin{pmatrix} 5 \\ -2 \end{pmatrix}$ and $\overrightarrow{QR} = \begin{pmatrix} 0 \\ 1 \end{pmatrix}$, find $|\overrightarrow{PR}|$.
15. If $\overrightarrow{WX} = \begin{pmatrix} 1 \\ 3 \end{pmatrix}$, $\overrightarrow{XY} = \begin{pmatrix} -2 \\ 1 \end{pmatrix}$ and $\overrightarrow{YZ} = \begin{pmatrix} 2 \\ -1 \end{pmatrix}$, find $|\overrightarrow{WZ}|$.
16. Given that $\overrightarrow{OP} = \begin{pmatrix} 0 \\ 5 \end{pmatrix}$ and $\overrightarrow{OQ} = \begin{pmatrix} n \\ 3 \end{pmatrix}$, find:
 - (a) $|\overrightarrow{OP}|$
 - (b) a value for n if $|\overrightarrow{OP}| = |\overrightarrow{OQ}|$
17. Given that $\overrightarrow{OA} = \begin{pmatrix} 5 \\ 12 \end{pmatrix}$ and $\overrightarrow{OB} = \begin{pmatrix} 0 \\ m \end{pmatrix}$, find:
 - (a) $|\overrightarrow{OA}|$
 - (b) a value for m if $|\overrightarrow{OA}| = |\overrightarrow{OB}|$

18. Given that $\overrightarrow{LM} = \begin{pmatrix} -3 \\ 4 \end{pmatrix}$ and $\overrightarrow{MN} = \begin{pmatrix} -15 \\ p \end{pmatrix}$, find:
- (a) $|\overrightarrow{LM}|$ (b) a value for p if $|\overrightarrow{MN}| = 3|\overrightarrow{LM}|$
19. \mathbf{a} and \mathbf{b} are two vectors and $|\mathbf{a}| = 3$.
Find the value of $|\mathbf{a} + \mathbf{b}|$ when:
- (a) $\mathbf{b} = 2\mathbf{a}$
(b) $\mathbf{b} = -3\mathbf{a}$
(c) \mathbf{b} is perpendicular to \mathbf{a} and $|\mathbf{b}| = 4$
20. \mathbf{r} and \mathbf{s} are two vectors and $|\mathbf{r}| = 5$.
Find the value of $|\mathbf{r} + \mathbf{s}|$ when:
- (a) $\mathbf{s} = 5\mathbf{r}$
(b) $\mathbf{s} = -2\mathbf{r}$
(c) \mathbf{r} is perpendicular to \mathbf{s} and $|\mathbf{s}| = 5$
(d) \mathbf{s} is perpendicular to $(\mathbf{r} + \mathbf{s})$ and $|\mathbf{s}| = 3$

8.5 Vector geometry

Example

In the diagram, $\overrightarrow{OD} = 2\overrightarrow{OA}$, $\overrightarrow{OE} = 4\overrightarrow{OB}$, $\overrightarrow{OA} = \mathbf{a}$ and $\overrightarrow{OB} = \mathbf{b}$.

- (a) Express \overrightarrow{OD} and \overrightarrow{OE} in terms of \mathbf{a} and \mathbf{b} respectively.
(b) Express \overrightarrow{BA} in terms of \mathbf{a} and \mathbf{b} .
(c) Express \overrightarrow{ED} in terms of \mathbf{a} and \mathbf{b} .
(d) Given that $\overrightarrow{BC} = 3\overrightarrow{BA}$, express \overrightarrow{OC} in terms of \mathbf{a} and \mathbf{b} .
(e) Express \overrightarrow{EC} in terms of \mathbf{a} and \mathbf{b} .
(f) Hence show that the points E, D and C lie on a straight line.

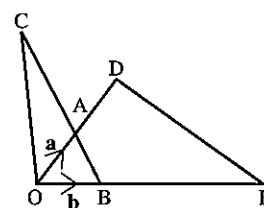

\overrightarrow{OD} , \overrightarrow{OC} and \overrightarrow{OB} are called position vectors.
The position vector \overrightarrow{OB} gives the position of B relative to the origin, O.

- (a) $\overrightarrow{OD} = 2\mathbf{a}$
 $\overrightarrow{OE} = 4\mathbf{b}$
- (b) $\overrightarrow{BA} = -\mathbf{b} + \mathbf{a}$
- (c) $\overrightarrow{ED} = -4\mathbf{b} + 2\mathbf{a}$
- (d) $\overrightarrow{OC} = \overrightarrow{OB} + \overrightarrow{BC}$
 $\overrightarrow{OC} = \mathbf{b} + 3(-\mathbf{b} + \mathbf{a})$
 $\overrightarrow{OC} = -2\mathbf{b} + 3\mathbf{a}$
- (e) $\overrightarrow{EC} = \overrightarrow{EO} + \overrightarrow{OC}$
 $\overrightarrow{EC} = -4\mathbf{b} + (-2\mathbf{b} + 3\mathbf{a})$
 $\overrightarrow{EC} = -6\mathbf{b} + 3\mathbf{a}$
- (f) Using the results for \overrightarrow{ED} and \overrightarrow{EC} , we see that $\overrightarrow{EC} = \frac{3}{2}\overrightarrow{ED}$.

Since \overrightarrow{EC} and \overrightarrow{ED} are parallel vectors which both pass through the point E, the points E, D and C must lie on a straight line.

Exercise 10

$$1. \begin{aligned} \overrightarrow{OD} &= 2\overrightarrow{OA}, \\ \overrightarrow{OE} &= 3\overrightarrow{OB}, \\ \overrightarrow{OA} &= \mathbf{a} \text{ and} \\ \overrightarrow{OB} &= \mathbf{b}. \end{aligned}$$

- Express \overrightarrow{OD} and \overrightarrow{OE} in terms of \mathbf{a} and \mathbf{b} respectively.
- Express \overrightarrow{BA} in terms of \mathbf{a} and \mathbf{b} .
- Express \overrightarrow{ED} in terms of \mathbf{a} and \mathbf{b} .
- Given that $\overrightarrow{BC} = 4\overrightarrow{BA}$, express \overrightarrow{OC} in terms of \mathbf{a} and \mathbf{b} .
- Express \overrightarrow{EC} in terms of \mathbf{a} and \mathbf{b} .
- Use the results for \overrightarrow{ED} and \overrightarrow{EC} to show that points E, D and C lie on a straight line.

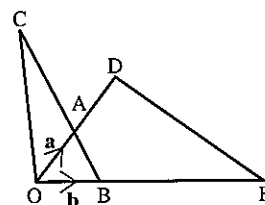

$$2. \begin{aligned} \overrightarrow{OY} &= 2\overrightarrow{OB}, \\ \overrightarrow{OX} &= \frac{5}{2}\overrightarrow{OA}, \\ \overrightarrow{OA} &= \mathbf{a} \text{ and} \\ \overrightarrow{OB} &= \mathbf{b}. \end{aligned}$$

- Express \overrightarrow{OY} and \overrightarrow{OX} in terms of \mathbf{b} and \mathbf{a} respectively.
- Express \overrightarrow{AB} in terms of \mathbf{a} and \mathbf{b} .
- Express \overrightarrow{XY} in terms of \mathbf{a} and \mathbf{b} .
- Given that $\overrightarrow{AC} = 6\overrightarrow{AB}$, express \overrightarrow{OC} in terms of \mathbf{a} and \mathbf{b} .
- Express \overrightarrow{XC} in terms of \mathbf{a} and \mathbf{b} .
- Use the results for \overrightarrow{XY} and \overrightarrow{XC} to show that points X, Y and C lie on a straight line.

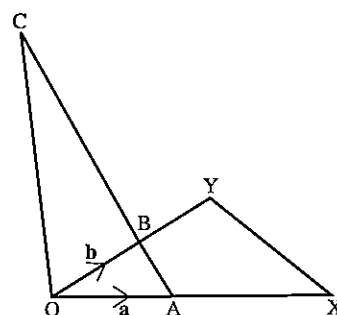

$$3. \begin{aligned} \overrightarrow{OA} &= \mathbf{a}, \\ \overrightarrow{OB} &= \mathbf{b}, \\ \overrightarrow{AQ} &= \frac{1}{2}\mathbf{a}, \\ \overrightarrow{BR} &= \mathbf{b} \text{ and} \\ \overrightarrow{AP} &= 2\overrightarrow{BA}. \end{aligned}$$

- Express \overrightarrow{BA} and \overrightarrow{BP} in terms of \mathbf{a} and \mathbf{b} .
- Express \overrightarrow{RQ} in terms of \mathbf{a} and \mathbf{b} .
- Express \overrightarrow{QA} and \overrightarrow{QP} in terms of \mathbf{a} and \mathbf{b} .
- Using the vectors for \overrightarrow{RQ} and \overrightarrow{QP} , show that R, Q and P lie on a straight line.

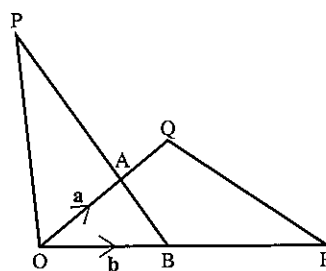

4. In the diagram, $\vec{OA} = \mathbf{a}$ and $\vec{OB} = \mathbf{b}$, M is the mid-point of OA and P lies on AB such that $\vec{AP} = \frac{2}{3}\vec{AB}$.
- Express \vec{AB} and \vec{AP} in terms of \mathbf{a} and \mathbf{b} .
 - Express \vec{MA} and \vec{MP} in terms of \mathbf{a} and \mathbf{b} .
 - If X lies on OB produced such that $OB = BX$, express \vec{MX} in terms of \mathbf{a} and \mathbf{b} .
 - Show that MPX is a straight line.

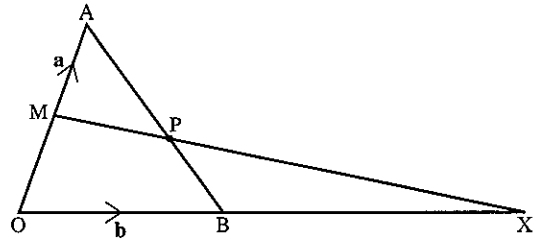

5. $\vec{OP} = \mathbf{a}$,
 $\vec{OA} = 3\mathbf{a}$,
 $\vec{OB} = \mathbf{b}$ and
 M is the mid-point of AB.
- Express \vec{BP} and \vec{AB} in terms of \mathbf{a} and \mathbf{b} .
 - Express \vec{MB} in terms of \mathbf{a} and \mathbf{b} .
 - If X lies on BP produced so that $\vec{BX} = k \cdot \vec{BP}$, express \vec{MX} in terms of \mathbf{a} , \mathbf{b} and k .
 - Find the value of k if MX is parallel to BO.

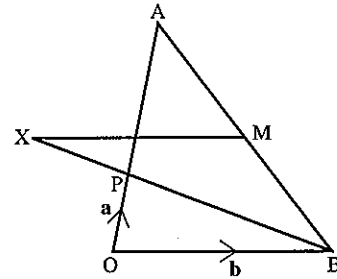

6. AC is parallel to OB,
 $\vec{AX} = \frac{1}{4}\vec{AB}$,
 $\vec{OA} = \mathbf{a}$,
 $\vec{OB} = \mathbf{b}$ and
 $\vec{AC} = m\mathbf{b}$.
- Express \vec{AB} in terms of \mathbf{a} and \mathbf{b} .
 - Express \vec{AX} in terms of \mathbf{a} and \mathbf{b} .
 - Express \vec{BC} in terms of \mathbf{a} , \mathbf{b} and m .
 - Given that OX is parallel to BC, find the value of m .

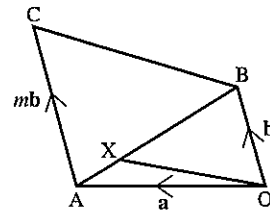

7. CY is parallel to OD,
 $\vec{CX} = \frac{1}{5}\vec{CD}$,
 $\vec{OC} = \mathbf{c}$,
 $\vec{OD} = \mathbf{d}$ and
 $\vec{CY} = n\mathbf{d}$.
- Express \vec{CD} in terms of \mathbf{c} and \mathbf{d} .
 - Express \vec{CX} in terms of \mathbf{c} and \mathbf{d} .
 - Express \vec{OX} in terms of \mathbf{c} and \mathbf{d} .
 - Express \vec{DY} in terms of \mathbf{c} , \mathbf{d} and n .
 - Given that OX is parallel to DY, find the value of n .

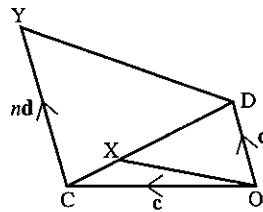

8. M is the mid-point of AB,
 N is the mid-point of OB,
 $\vec{OA} = \mathbf{a}$ and
 $\vec{OB} = \mathbf{b}$.

- (a) Express \vec{AB} , \vec{AM} and \vec{OM} in terms of \mathbf{a} and \mathbf{b} .
 (b) Given that G lies on OM such that
 $OG : GM = 2 : 1$, express \vec{OG} in terms of \mathbf{a} and \mathbf{b} .
 (c) Express \vec{AG} in terms of \mathbf{a} and \mathbf{b} .
 (d) Express \vec{AN} in terms of \mathbf{a} and \mathbf{b} .
 (e) Show that $\vec{AG} = m\vec{AN}$ and find the value of m .

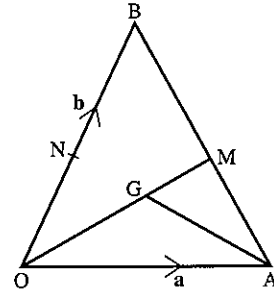

9. M is the mid-point of AC and N is the mid-point of OB,
 $\vec{OA} = \mathbf{a}$,
 $\vec{OB} = \mathbf{b}$ and
 $\vec{OC} = \mathbf{c}$.

- (a) Express \vec{AB} in terms of \mathbf{a} and \mathbf{b} .
 (b) Express \vec{ON} in terms of \mathbf{b} .
 (c) Express \vec{AC} in terms of \mathbf{a} and \mathbf{c} .
 (d) Express \vec{AM} in terms of \mathbf{a} and \mathbf{c} .
 (e) Express \vec{OM} in terms of \mathbf{a} and \mathbf{c} .
 (f) Express \vec{NM} in terms of \mathbf{a} , \mathbf{b} and \mathbf{c} .
 (g) If N and M coincide, write down an equation connecting \mathbf{a} , \mathbf{b} and \mathbf{c} .

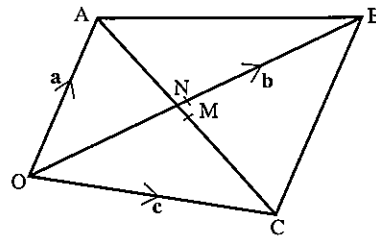

10. $\vec{OA} = \mathbf{a}$ and
 $\vec{OB} = \mathbf{b}$.

- (a) Express \vec{BA} in terms of \mathbf{a} and \mathbf{b} .
 (b) Given that $\vec{BX} = m\vec{BA}$, show that $\vec{OX} = m\mathbf{a} + (1 - m)\mathbf{b}$.
 (c) Given that $OP = 4\mathbf{a}$ and $\vec{PQ} = 2\mathbf{b}$, express \vec{OQ} in terms of \mathbf{a} and \mathbf{b} .
 (d) Given that $\vec{OX} = n\vec{OQ}$ use the results for \vec{OX} and \vec{OQ} to find the values of m and n .

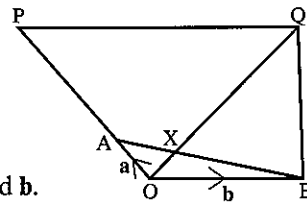

11. X is the mid-point of OD, Y lies on CD such that
 $\vec{CY} = \frac{1}{4}\vec{CD}$,
 $\vec{OC} = \mathbf{c}$ and
 $\vec{OD} = \mathbf{d}$.

- (a) Express \vec{CD} , \vec{CY} and \vec{OY} in terms of \mathbf{c} and \mathbf{d} .
 (b) Express \vec{CX} in terms of \mathbf{c} and \mathbf{d} .
 (c) Given that $\vec{CZ} = h\vec{CX}$, express \vec{OZ} in terms of \mathbf{c} , \mathbf{d} and h .
 (d) If $\vec{OZ} = k\vec{OY}$, form an equation and hence find the values of h and k .

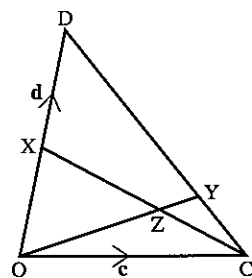

8.6 Functions

The idea of a function is used in almost every branch of mathematics. The two common notations used are:

(a) $f(x) = x^2 + 4$ (b) $f: x \mapsto x^2 + 4$

We may interpret (b) as follows: 'function f such that x is mapped onto $x^2 + 4$ '.

Example

If $f(x) = 3x - 1$ and $g(x) = 1 - x^2$ find:

(a) $f(2)$ (b) $f(-2)$ (c) $g(0)$ (d) $g(3)$ (e) x if $f(x) = 1$

(a) $f(2) = 5$ (b) $f(-2) = -7$ (c) $g(0) = 1$ (d) $g(3) = -8$

(e) If $f(x) = 1$
Then $3x - 1 = 1$
 $3x = 2$
 $x = \frac{2}{3}$

Flow diagrams

The function f in the example consisted of two simpler functions as illustrated by a flow diagram.

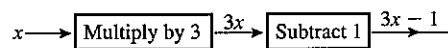

It is obviously important to 'multiply by 3' and 'subtract 1' in the correct order.

Example

Draw flow diagrams for the functions:

(a) $f: x \mapsto (2x + 5)^2$, (b) $g(x) = \frac{5 - 7x}{3}$

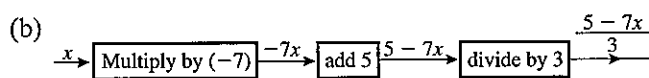
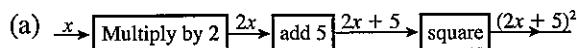

Exercise 11

1. Given the functions $h: x \mapsto x^2 + 1$ and $g: x \mapsto 10x + 1$. Find:

(a) $h(2), h(-3), h(0)$ (b) $g(2), g(10), g(-3)$

In questions 2 to 15, draw a flow diagram for each function.

2. $f: x \mapsto 5x + 4$

3. $f: x \mapsto 3(x - 4)$

4. $f: x \mapsto (2x + 7)^2$

5. $f: x \mapsto \left(\frac{9 + 5x}{4}\right)$

6. $f: x \mapsto \frac{4 - 3x}{5}$

7. $f: x \mapsto 2x^2 + 1$

8. $f: x \mapsto \frac{3x^2}{2} + 5$

9. $f: x \mapsto \sqrt{(4x - 5)}$

10. $f: x \mapsto 4\sqrt{(x^2 + 10)}$

11. $f: x \mapsto (7 - 3x)^2$

12. $f: x \mapsto 4(3x + 1)^2 + 5$

13. $f: x \mapsto 5 - x^2$

14. $f: x \mapsto \frac{10\sqrt{(x^2 + 1)} + 6}{4}$

15. $f: x \mapsto \left(\frac{x^3}{4} + 1\right)^2 - 6$

For questions 16, 17 and 18, the functions f , g and h are defined as follows:

$$f: x \mapsto 1 - 2x$$

$$g: x \mapsto \frac{x^3}{10}$$

$$h: x \mapsto \frac{12}{x}$$

16. Find:

(a) $f(5)$, $f(-5)$, $f(\frac{1}{4})$

(b) $g(2)$, $g(-3)$, $g(\frac{1}{2})$

(c) $h(3)$, $h(10)$, $h(\frac{1}{3})$

17. Find:

(a) x if $f(x) = 1$ (b) x if $f(x) = -11$ (c) x if $h(x) = 1$

18. Find:

(a) y if $g(y) = 100$ (b) z if $h(z) = 24$ (c) w if $g(w) = 0.8$

For questions 19 and 20, the functions k , l and m are defined as follows:

$$k: x \mapsto \frac{2x^2}{3}$$

$$l: x \mapsto \sqrt{[(y - 1)(y - 2)]}$$

$$m: x \mapsto 10 - x^2$$

19. Find:

(a) $k(3)$, $k(6)$, $k(-3)$

(b) $l(2)$, $l(0)$, $l(4)$

(c) $m(4)$, $m(-2)$, $m(\frac{1}{2})$

20. Find:

(a) x if $k(x) = 6$

(b) x if $m(x) = 1$

(c) y if $k(y) = 2\frac{2}{3}$

(d) p if $m(p) = -26$

21. $f(x)$ is defined as the product of the digits of x ,

e.g. $f(12) = 1 \times 2 = 2$

(a) Find: (i) $f(25)$ (ii) $f(713)$

(b) If x is an integer with three digits, find:

(i) x such that $f(x) = 1$

(ii) the largest x such that $f(x) = 4$

(iii) the largest x such that $f(x) = 0$

(iv) the smallest x such that $f(x) = 2$

Example

Find the inverse of f where $f: x \rightarrow \frac{5x-2}{3}$.

(a) Draw a flow diagram for f .

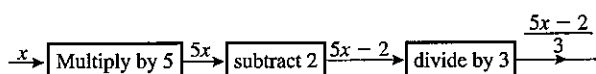

(b) Draw a new flow diagram with each operation replaced by its inverse. Start with x on the right.

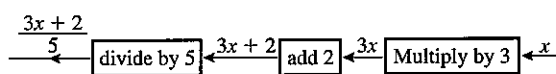

Thus the inverse of f is given by

$$f^{-1}: x \mapsto \frac{3x+2}{5} \quad \text{or} \quad f^{-1}(x) = \frac{3x+2}{5}$$

Exercise 12

For questions 1 and 2, the functions f , g and h are as follows:

$$f: x \mapsto 4x$$

$$g: x \mapsto x+5$$

$$h: x \mapsto x^2$$

1. Find the following in the form ' $x \mapsto \dots$ '

- (a) fg (b) gf (c) hf (d) fh
 (e) gh (f) fgg (g) hfg

2. Find:

- (a) x if $hg(x) = h(x)$ (b) x if $fh(x) = gh(x)$

For questions 3, 4 and 5, the functions f , g and h are as follows:

$$f: x \mapsto 2x$$

$$g: x \mapsto x-3$$

$$h: x \mapsto x^2$$

3. Find the following in the form ' $x \mapsto \dots$ '

- (a) fg (b) gf (c) gh
 (d) hf (e) ghf (f) hgf

4. Evaluate:

- (a) $fg(4)$ (b) $gf(7)$ (c) $gh(-3)$
 (d) $fgf(2)$ (e) $ggg(10)$ (f) $hfh(-2)$

5. Find:

- (a) x if $f(x) = g(x)$ (b) x if $hg(x) = gh(x)$
 (c) x if $gf(x) = 0$ (d) x if $fg(x) = 4$

For questions 6, 7 and 8, the functions, l , m and n are as follows:

$$l : x \mapsto 2x + 1$$

$$m : x \mapsto 3x - 1$$

$$n : x \mapsto x^2$$

6. Find the following in the form ' $x \mapsto \dots$ '

- (a) lm (b) ml (c) ln
 (d) nm (e) lnm (f) mln

7. Find:

- (a) $lm(2)$ (b) $nl(1)$ (c) $mn(-2)$
 (d) $mm(2)$ (e) $nln(2)$ (f) $llm(0)$

8. Find:

- (a) x if $l(x) = m(x)$
 (b) two values of x if $nl(x) = nm(x)$
 (c) x if $ln(x) = mn(x)$

In questions 9 to 22, find the inverse of each function in the form ' $x \mapsto \dots$ '

9. $f : x \mapsto 5x - 2$

10. $f : x \mapsto 5(x - 2)$

11. $f : x \mapsto 3(2x + 4)$

12. $g : x \mapsto \frac{2x + 1}{3}$

13. $f : x \mapsto \frac{3(x - 1)}{4}$

14. $g : x \mapsto 2(3x + 4) - 6$

15. $h : x \mapsto \frac{1}{2}(4 + 5x) + 10$

16. $k : x \mapsto -7x + 3$

17. $j : x \mapsto \frac{12 - 5x}{3}$

18. $l : x \mapsto \frac{4 - x}{3} + 2$

19. $m : x \mapsto \frac{\left[\frac{(2x - 1)}{4} - 3 \right]}{5}$

20. $f : x \mapsto \frac{3(10 - 2x)}{7}$

21. $g : x \mapsto \left[\frac{\frac{x}{4} + 6}{5} \right] + 7$

22. A calculator has the following function buttons:

$x \mapsto x^2$; $x \mapsto \sqrt{x}$; $x \mapsto \frac{1}{x}$; $x \mapsto \log x$;
 $x \mapsto \ln x$; $x \mapsto \sin x$; $x \mapsto \cos x$; $x \mapsto \tan x$; $x \mapsto x!$

Find which button was used for the following input/outputs:

- (a) $1\,000\,000 \rightarrow 1000$ (b) $1000 \rightarrow 3$
 (c) $3 \rightarrow 6$ (d) $0.2 \rightarrow 0.04$
 (e) $10 \rightarrow 0.1$ (f) $45 \rightarrow 1$
 (g) $0.5 \rightarrow 2$ (h) $64 \rightarrow 8$
 (i) $60 \rightarrow 0.5$ (j) $1 \rightarrow 0$
 (k) $135 \rightarrow -1$ (l) $10 \rightarrow 3\,628\,800$
 (m) $0 \rightarrow 1$ (n) $30 \rightarrow 0.5$
 (o) $90 \rightarrow 0$ (p) $0.4 \rightarrow 2.5$
 (q) $4 \rightarrow 24$ (r) $1\,000\,000 \rightarrow 6$

$x!$ is x factorial
 $4! = 4 \times 3 \times 2 \times 1$
 $3! = 3 \times 2 \times 1$ etc

Revision exercise 8A

- Given that $\mathcal{E} = \{1, 2, 3, 4, 5, 6, 7, 8\}$,
 $A = \{1, 3, 5\}$, $B = \{5, 6, 7\}$, list the members of the sets:
 (a) $A \cap B$ (b) $A \cup B$ (c) A'
 (d) $A' \cap B'$ (e) $A \cup B'$
- The sets P and Q are such that $n(P \cup Q) = 50$, $n(P \cap Q) = 9$ and $n(P) = 27$. Find the value of $n(Q)$.
- Draw three diagrams similar to Figure 1, and shade the following
 (a) $Q \cap R'$ (b) $(P \cup Q) \cap R$ (c) $(P \cap Q) \cap R'$

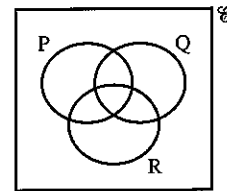

Figure 1

- Describe the shaded regions in Figures 2 and 3.

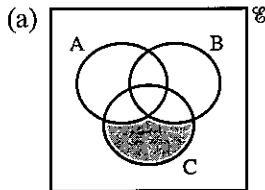

Figure 2

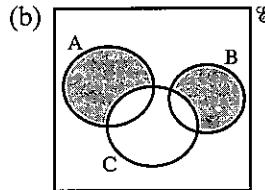
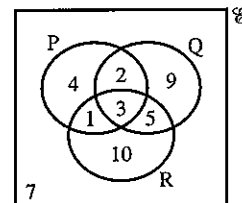
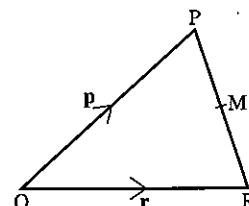

Figure 3

- Given that $\mathcal{E} = \{\text{people on a train}\}$, $M = \{\text{males}\}$,
 $T = \{\text{people over 25 years old}\}$ and $S = \{\text{snooker players}\}$,
 (a) express in set notation:
 (i) all the snooker players are over 25
 (ii) some snooker players are women
 (b) express in words: $T \cap M' = \emptyset$
- The figures in the diagram indicate the number of elements in each subset of \mathcal{E} .
 (a) Find $n(P \cap R)$.
 (b) Find $n(Q \cup R)'$.
 (c) Find $n(P' \cap Q')$.



- In $\triangle OPR$, the mid-point of PR is M .
 If $\vec{OP} = \mathbf{p}$ and $\vec{OR} = \mathbf{r}$, find in terms of \mathbf{p} and \mathbf{r} :
 (a) \vec{PR} (b) \vec{PM} (c) \vec{OM}



8. If $\mathbf{a} = \begin{pmatrix} 1 \\ 4 \end{pmatrix}$ and $\mathbf{b} = \begin{pmatrix} -3 \\ 4 \end{pmatrix}$, find:
- (a) $|\mathbf{b}|$ (b) $|\mathbf{a} + \mathbf{b}|$ (c) $|2\mathbf{a} - \mathbf{b}|$
9. If $4\begin{pmatrix} 1 \\ 3 \end{pmatrix} + 2\begin{pmatrix} 1 \\ m \end{pmatrix} = 3\begin{pmatrix} n \\ -6 \end{pmatrix}$, find the values of m and n .
10. The points O, A and B have coordinates (0, 0), (5, 0) and (-1, 4) respectively. Write as column vectors.
- (a) \overrightarrow{OB} (b) $\overrightarrow{OA} + \overrightarrow{OB}$ (c) $\overrightarrow{OA} - \overrightarrow{OB}$
 (d) \overrightarrow{OM} where M is the mid-point of AB.
11. In the parallelogram OABC, M is the mid-point of AB and N is the mid-point of BC.
 If $\overrightarrow{OA} = \mathbf{a}$ and $\overrightarrow{OC} = \mathbf{c}$, express in terms of \mathbf{a} and \mathbf{c} :
- (a) \overrightarrow{CA} (b) \overrightarrow{ON} (c) \overrightarrow{NM}
 Describe the relationship between CA and NM.
12. The vectors \mathbf{a} , \mathbf{b} , \mathbf{c} are given by:
- $$\mathbf{a} = \begin{pmatrix} 1 \\ 5 \end{pmatrix}, \mathbf{b} = \begin{pmatrix} -2 \\ 1 \end{pmatrix}, \mathbf{c} = \begin{pmatrix} -1 \\ 17 \end{pmatrix}$$
- Find numbers m and n so that $m\mathbf{a} + n\mathbf{b} = \mathbf{c}$.
13. Given that $\overrightarrow{OP} = \begin{pmatrix} 3 \\ 2 \end{pmatrix}$, $\overrightarrow{OQ} = \begin{pmatrix} 0 \\ 4 \end{pmatrix}$ and that M is the mid-point of PQ, express as column vectors:
- (a) \overrightarrow{PQ} (b) \overrightarrow{PM} (c) \overrightarrow{OM}
14. Given $f: x \mapsto 2x - 3$ and $g: x \mapsto x^2 - 1$, find:
- (a) $f(-1)$ (b) $g(-1)$ (c) $fg(-1)$ (d) $gf(3)$
 Write the function ff in the form ' $ff: x \mapsto \dots$ '
15. If $f: x \mapsto 3x + 4$ and $h: x \mapsto \frac{x-2}{5}$
 express f^{-1} and h^{-1} in the form ' $x \mapsto \dots$ '.
 Find: (a) $f^{-1}(13)$ (b) the value of z if $f(z) = 20$
16. Given that $f(x) = x - 5$, find:
- (a) the value of s such that $f(s) = -2$
 (b) the values of t such that $t \times f(t) = 0$

Examination exercise 8B

1. $\mathcal{E} = \{x: x \text{ is a positive integer}\}$, $A = \{x: 3x - 2 < 15\}$,
 $B = \{x: 4x + 1 \geq 13\}$.
 (a) Find $n(A)$. (b) List the set $A \cap B$. J 98 2

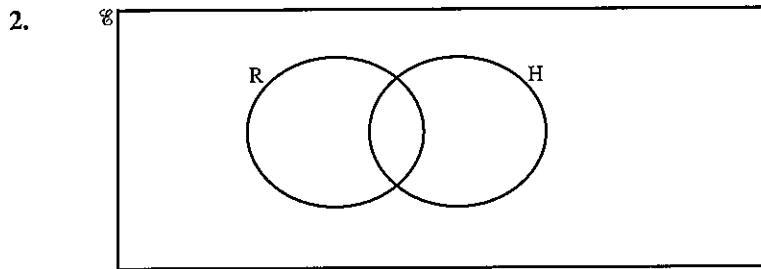

$\mathcal{E} = \{\text{quadrilaterals}\}$, $R = \{\text{rectangles}\}$ and $H = \{\text{rhombuses}\}$.

- (a) Which special quadrilaterals belong to $R \cap H$?
 (b) $P = \{\text{parallelograms}\}$. Draw and label P on the diagram above.
 (c) A quadrilateral, x , has unequal diagonals which bisect each other at 90° .
 Mark x on the diagram above. J 95 2

3. $\mathcal{E} = \{x: x \text{ is an integer and } 2 \leq x \leq 10\}$,
 $A = \{\text{multiples of } 3\}$,
 $B = \{\text{prime numbers}\}$.
 List the members of:
 (a) $A \cap B$ (b) $A \cup B$ (c) $(A \cup B)'$ N 95 2

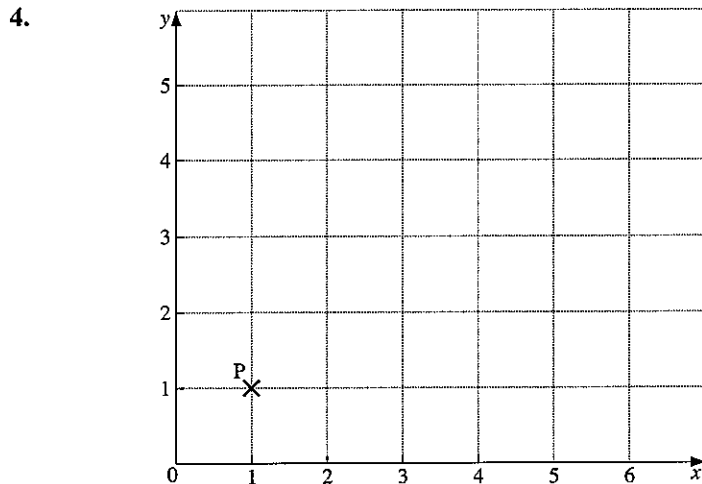

P is the point $(1, 1)$. The vector $\mathbf{m} = \begin{pmatrix} 2 \\ 3 \end{pmatrix}$ and $\mathbf{n} = \begin{pmatrix} 1 \\ -1 \end{pmatrix}$.

- (a) Find the vector $\mathbf{m} + 2\mathbf{n}$.
 (b) $\overrightarrow{PQ} = \mathbf{m} + 2\mathbf{n}$. Find the position vector of Q .
 (c) Calculate $|\mathbf{m}|$, the magnitude of \mathbf{m} . J 96 2

5. In the diagram, O is the origin, ABC is a straight line and M is the mid-point of OA.

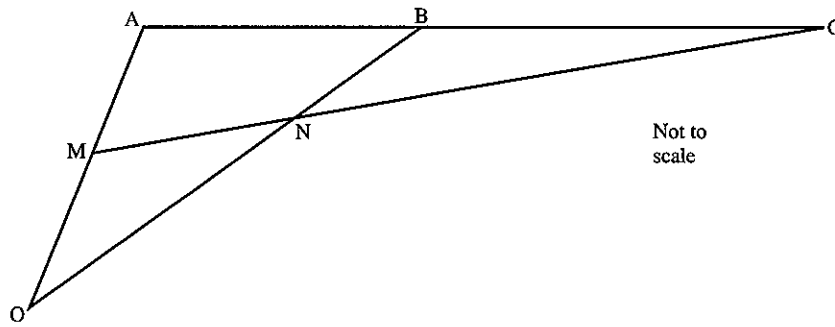

$$\overrightarrow{OA} = \mathbf{a}, \overrightarrow{OB} = \mathbf{b} \text{ and } \overrightarrow{AC} = 3\overrightarrow{AB}$$

- (a) Find, in terms of \mathbf{a} and/or \mathbf{b} , in their simplest forms:
 (i) \overrightarrow{MA} (ii) \overrightarrow{AB} (iii) \overrightarrow{AC} (iv) \overrightarrow{MC}
 (v) the position vector of C.
- (b) It is also given that $\overrightarrow{MN} = \frac{1}{5}\overrightarrow{MC}$.
 (i) Find \overrightarrow{ON} in terms of \mathbf{a} and/or \mathbf{b} .
 (ii) Find the ratio $ON : NB$. N 95 4
6. $f(x) = \sqrt{3x+1}$ for $x \geq -\frac{1}{3}$
 (a) Find $f(3\frac{3}{4})$.
 (b) Solve $f(x) = 5$.
 (c) Find $f^{-1}(x)$. J 95 2
7. $f(x) = x^2 - 16$ and $g(x) = 5x + 2$ for all values of x .
 (a) Find:
 (i) $f(10)$
 (ii) $f(-2)$
 (b) Find $g^{-1}(x)$, the inverse of $g(x)$.
 (c) Find $fg(x)$, giving the answer in its simplest terms.
 (d) Find the two values of x for which $f(x) = g(x)$.
 Give your answers correct to two decimal places. N 98 4
8. $f(x) = 3x^2 - 3x + 1$
 (a) Find the exact value of $f(\frac{1}{6})$.
 (b) $f(1-x) = 3(1-x)^2 - 3(1-x) + 1$
 Show that $f(1-x) = f(x)$.
 (c) Write down the value of $f(\frac{5}{6})$. N 96 2
9. $\mathbf{a} = \begin{pmatrix} 2 \\ -3 \end{pmatrix}$ and $\mathbf{b} = \begin{pmatrix} 5 \\ -1 \end{pmatrix}$. Find $3\mathbf{a} - 2\mathbf{b}$. J 03 2

9 MATRICES AND TRANSFORMATIONS

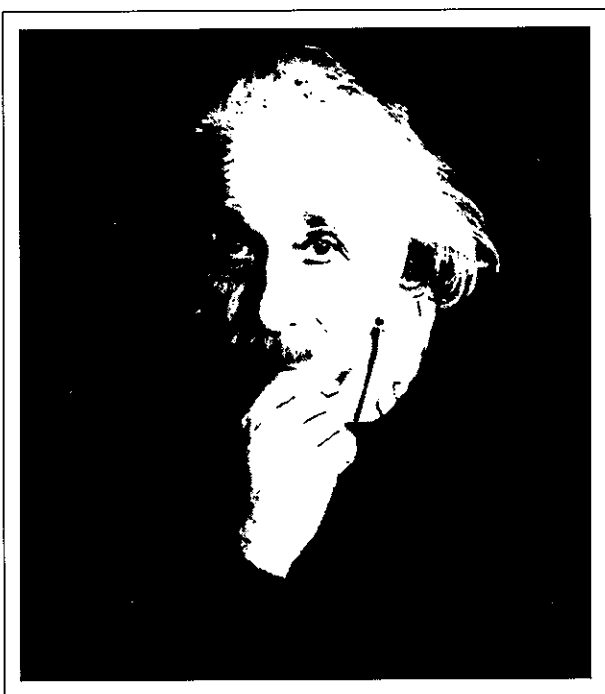

Albert Einstein (1879–1955) working as a patent office clerk in Berne, was responsible for the greatest advance in mathematical physics of this century. His theories of relativity, put forward in 1905 and 1915 were based on the postulate that the velocity of light is absolute: mass, length and even time can only be measured relative to the observer and undergo transformation when studied by another observer. His formula $E = mc^2$ laid the foundations of nuclear physics, a fact that he came to deplore in its application to warfare. In 1933 he moved from Nazi Germany and settled in America.

- 36** Display information in the form of a matrix; calculate the sum and product of two matrices; calculate the product of a matrix and a scalar quantity; calculate the determinant and inverse
- 37** Use the following transformations: reflection, rotation, translation, enlargement, shear, stretching and their combinations; identify and give descriptions of transformations connecting given figures; describe transformations using coordinates and matrices

9.1 Matrix operations

Addition and subtraction

Matrices of the same order are added (or subtracted) by adding (or subtracting) the corresponding elements in each matrix.

Example

$$\begin{pmatrix} 2 & -4 \\ 3 & 0 \end{pmatrix} + \begin{pmatrix} 3 & 5 \\ -1 & 7 \end{pmatrix} = \begin{pmatrix} 5 & 1 \\ 2 & 7 \end{pmatrix}$$

Multiplication by a number

Each element of the matrix is multiplied by the multiplying number.

Example

$$3 \times \begin{pmatrix} 2 & -1 \\ 1 & 4 \end{pmatrix} = \begin{pmatrix} 6 & -3 \\ 3 & 12 \end{pmatrix}$$

Multiplication by another matrix

For 2×2 matrices,

$$\begin{pmatrix} a & b \\ c & d \end{pmatrix} \begin{pmatrix} w & x \\ y & z \end{pmatrix} = \begin{pmatrix} aw + by & ax + bz \\ cw + dy & cx + dz \end{pmatrix}$$

The same process is used for matrices of other orders.

Example

Perform the following multiplications.

$$(a) \begin{pmatrix} 3 & 2 \\ 4 & 1 \end{pmatrix} \begin{pmatrix} 2 & 1 \\ 1 & 5 \end{pmatrix} = \begin{pmatrix} 6+2 & 3+10 \\ 8+1 & 4+5 \end{pmatrix} = \begin{pmatrix} 8 & 13 \\ 9 & 9 \end{pmatrix}$$

$$(b) \begin{pmatrix} 2 & 1 & -2 \\ 0 & 1 & 3 \end{pmatrix} \begin{pmatrix} 1 & 0 \\ 1 & -2 \\ 4 & 3 \end{pmatrix} = \begin{pmatrix} 2+1-8 & 0-2-6 \\ 0+1+12 & 0-2+9 \end{pmatrix} \\ = \begin{pmatrix} -5 & -8 \\ 13 & 7 \end{pmatrix}$$

Matrices may be multiplied only if they are *compatible*. The number of *columns* in the left-hand matrix must equal the number of *rows* in the right-hand matrix.

Matrix multiplication is not commutative, i.e. for square matrices **A** and **B**, the product **AB** does not necessarily equal the product **BA**.

Note
In matrices, A^2 means
 $A \times A$. You must multiply
the matrices together.

Exercise 1

In questions 1 to 36, the matrices have the following values:

$$\mathbf{A} = \begin{pmatrix} 2 & -1 \\ 3 & 4 \end{pmatrix}; \quad \mathbf{B} = \begin{pmatrix} 0 & 5 \\ 1 & -2 \end{pmatrix}; \quad \mathbf{C} = \begin{pmatrix} 4 & 3 \\ 1 & -2 \end{pmatrix}; \quad \mathbf{D} = \begin{pmatrix} 1 & 5 & 1 \\ 4 & -6 & 1 \end{pmatrix}; \quad \mathbf{E} = \begin{pmatrix} 1 & 0 \\ -1 & 1 \\ 2 & 5 \end{pmatrix};$$

$$\mathbf{F} = (4 \ 5); \quad \mathbf{G} = \begin{pmatrix} 4 \\ 1 \\ 3 \end{pmatrix}; \quad \mathbf{H} = \begin{pmatrix} 0 & 1 & -2 \\ 3 & -4 & 5 \end{pmatrix}; \quad \mathbf{J} = \begin{pmatrix} 3 \\ 1 \end{pmatrix}; \quad \mathbf{K} = \begin{pmatrix} 1 & -3 \\ 0 & 1 \\ -7 & 0 \end{pmatrix}$$

Calculate the resultant value for each question where possible.

1. **A + B**

2. **D + H**

3. **J + F**

4. **B - C**

5. **2F**

6. **3B**

- | | | |
|--|---|--|
| 7. $\mathbf{K} - \mathbf{E}$ | 8. $2\mathbf{A} + \mathbf{B}$ | 9. $\mathbf{G} - \mathbf{J}$ |
| 10. $\mathbf{C} + \mathbf{B} + \mathbf{A}$ | 11. $2\mathbf{E} - 3\mathbf{K}$ | 12. $\frac{1}{2}\mathbf{A} - \mathbf{B}$ |
| 13. \mathbf{AB} | 14. \mathbf{BA} | 15. \mathbf{BC} |
| 16. \mathbf{CB} | 17. \mathbf{DG} | 18. \mathbf{AJ} |
| 19. \mathbf{HK} | 20. $(\mathbf{AB})\mathbf{C}$ | 21. $\mathbf{A}(\mathbf{BC})$ |
| 22. \mathbf{AF} | 23. \mathbf{CK} | 24. \mathbf{GF} |
| 25. $\mathbf{B}(2\mathbf{A})$ | 26. $(\mathbf{D} + \mathbf{H})\mathbf{G}$ | 27. \mathbf{JF} |
| 28. \mathbf{FJ} | 29. $(\mathbf{A} - \mathbf{C})\mathbf{D}$ | 30. \mathbf{A}^2 |
| 31. \mathbf{A}^4 | 32. \mathbf{E}^2 | 33. \mathbf{KH} |
| 34. $(\mathbf{CA})\mathbf{J}$ | 35. \mathbf{ED} | 36. \mathbf{B}^4 |

In questions 37 to 46, find the value of the letters.

37. $\begin{pmatrix} 2 & x \\ y & 7 \end{pmatrix} + \begin{pmatrix} 4 & y \\ -3 & 2 \end{pmatrix} = \begin{pmatrix} x & 9 \\ z & 9 \end{pmatrix}$
38. $\begin{pmatrix} x & 2 \\ -1 & -2 \\ w & 3 \end{pmatrix} + \begin{pmatrix} x & y \\ y & -3 \\ v & 5 \end{pmatrix} = \begin{pmatrix} 8 & z \\ x & w \\ w & 8 \end{pmatrix}$
39. $\begin{pmatrix} a & b \\ c & 0 \end{pmatrix} - \begin{pmatrix} 2 & 5 \\ -3 & d \end{pmatrix} = 2\begin{pmatrix} 1 & a \\ b & -1 \end{pmatrix}$
40. $\begin{pmatrix} x & 3 \\ -2 & y \end{pmatrix} \begin{pmatrix} 2 \\ 1 \end{pmatrix} = \begin{pmatrix} 5 \\ 0 \end{pmatrix}$
41. $\begin{pmatrix} 2 & 0 \\ 0 & -3 \end{pmatrix} \begin{pmatrix} m \\ n \end{pmatrix} = \begin{pmatrix} 10 \\ 1 \end{pmatrix}$
42. $\begin{pmatrix} p & 2 & -1 \\ q & -2 & 2q \end{pmatrix} \begin{pmatrix} 2 \\ 1 \\ 3 \end{pmatrix} = \begin{pmatrix} 5 \\ -10 \end{pmatrix}$
43. $\begin{pmatrix} 3 & 0 \\ 2 & x \end{pmatrix} \begin{pmatrix} y & z \\ 4 & 0 \end{pmatrix} = \begin{pmatrix} 6 & -3 \\ 8 & w \end{pmatrix}$
44. $\begin{pmatrix} 3y & 3z \\ 2y + 4x & 2z \end{pmatrix} = \begin{pmatrix} 6 & -3 \\ 8 & w \end{pmatrix}$
45. $\begin{pmatrix} 2 & e \\ a & 3 \end{pmatrix} + k\begin{pmatrix} 3 & 1 \\ 0 & -2 \end{pmatrix} = \begin{pmatrix} 8 & 6 \\ -3 & -1 \end{pmatrix}$
46. $\begin{pmatrix} 4 & 0 \\ 1 & m \end{pmatrix} \begin{pmatrix} n & p \\ -2 & 0 \end{pmatrix} = \begin{pmatrix} 20 & 12 \\ -1 & q \end{pmatrix}$
47. If $\mathbf{A} = \begin{pmatrix} 1 & 0 \\ 3 & 2 \end{pmatrix}$, $\mathbf{B} = \begin{pmatrix} x & 0 \\ 1 & 3 \end{pmatrix}$, and $\mathbf{AB} = \mathbf{BA}$, find x .
48. If $\mathbf{X} = \begin{pmatrix} k & 2 \\ 2 & -k \end{pmatrix}$ and $\mathbf{X}^2 = 5\begin{pmatrix} 1 & 0 \\ 0 & 1 \end{pmatrix}$, find k .
49. $\mathbf{B} = \begin{pmatrix} 3 & 3 \\ -1 & -1 \end{pmatrix}$
- (a) Find k if $\mathbf{B}^2 = k\mathbf{B}$
 (b) Find m if $\mathbf{B}^4 = m\mathbf{B}$
50. $\mathbf{A} = \begin{pmatrix} 5 & 5 \\ -2 & -2 \end{pmatrix}$
- (a) Find n if $\mathbf{A}^2 = n\mathbf{A}$
 (b) Find q if $\mathbf{A}^3 = q\mathbf{A}$

9.2 The inverse of a matrix

The inverse of a matrix \mathbf{A} is written \mathbf{A}^{-1} , and the inverse exists if

$$\mathbf{A}\mathbf{A}^{-1} = \mathbf{A}^{-1}\mathbf{A} = \mathbf{I}$$

where \mathbf{I} is called the identity matrix.

Only square matrices possess an inverse.

For 2×2 matrices, $\mathbf{I} = \begin{pmatrix} 1 & 0 \\ 0 & 1 \end{pmatrix}$

For 3×3 matrices, $\mathbf{I} = \begin{pmatrix} 1 & 0 & 0 \\ 0 & 1 & 0 \\ 0 & 0 & 1 \end{pmatrix}$, etc.

If $\mathbf{A} = \begin{pmatrix} a & b \\ c & d \end{pmatrix}$, the inverse \mathbf{A}^{-1} is given by $\mathbf{A}^{-1} = \frac{1}{(ad - cb)} \begin{pmatrix} d & -b \\ -c & a \end{pmatrix}$

Here, the number $(ad - cb)$ is called the *determinant* of the matrix and is written $|\mathbf{A}|$.

If $|\mathbf{A}| = 0$, then the matrix has no inverse.

Example

Find the inverse of $\mathbf{A} = \begin{pmatrix} 3 & -4 \\ 1 & -2 \end{pmatrix}$.

$$\mathbf{A}^{-1} = \frac{1}{[3(-2) - 1(-4)]} \begin{pmatrix} -2 & 4 \\ -1 & 3 \end{pmatrix} = \frac{1}{-2} \begin{pmatrix} -2 & 4 \\ -1 & 3 \end{pmatrix}$$

$$\begin{aligned} \text{Check: } \mathbf{A}^{-1}\mathbf{A} &= \frac{1}{-2} \begin{pmatrix} -2 & 4 \\ -1 & 3 \end{pmatrix} \begin{pmatrix} 3 & -4 \\ 1 & -2 \end{pmatrix} = \frac{-1}{2} \begin{pmatrix} -2 & 0 \\ 0 & -2 \end{pmatrix} \\ &= \begin{pmatrix} 1 & 0 \\ 0 & 1 \end{pmatrix} \end{aligned}$$

Multiplying by the inverse of a matrix gives the same result as dividing by the matrix: the effect is similar to ordinary algebraic operations.

e.g. if $\mathbf{AB} = \mathbf{C}$
 $\mathbf{A}^{-1}\mathbf{AB} = \mathbf{A}^{-1}\mathbf{C}$
 $\mathbf{B} = \mathbf{A}^{-1}\mathbf{C}$

Exercise 2

In questions 1 to 15, find the inverse of the matrix.

1. $\begin{pmatrix} 4 & 1 \\ 3 & 1 \end{pmatrix}$

2. $\begin{pmatrix} 1 & 2 \\ 2 & 5 \end{pmatrix}$

3. $\begin{pmatrix} 3 & 4 \\ 1 & 2 \end{pmatrix}$

4. $\begin{pmatrix} 5 & 2 \\ 1 & 1 \end{pmatrix}$

5. $\begin{pmatrix} 2 & -2 \\ -1 & 2 \end{pmatrix}$

6. $\begin{pmatrix} 4 & -3 \\ -1 & 2 \end{pmatrix}$

7. $\begin{pmatrix} 2 & 1 \\ -2 & 3 \end{pmatrix}$

8. $\begin{pmatrix} 0 & -3 \\ 2 & 4 \end{pmatrix}$

9. $\begin{pmatrix} -1 & -2 \\ 1 & -3 \end{pmatrix}$



10. $\begin{pmatrix} 2 & 4 \\ 1 & 2 \end{pmatrix}$

11. $\begin{pmatrix} 3 & -2 \\ 1 & 4 \end{pmatrix}$

12. $\begin{pmatrix} -3 & 1 \\ 2 & 1 \end{pmatrix}$

13. $\begin{pmatrix} 2 & -3 \\ 1 & -4 \end{pmatrix}$

14. $\begin{pmatrix} 7 & 0 \\ -5 & 1 \end{pmatrix}$

15. $\begin{pmatrix} 2 & 1 \\ -2 & -4 \end{pmatrix}$

16. If $\mathbf{B} = \begin{pmatrix} 2 & 4 \\ 1 & 3 \end{pmatrix}$ and $\mathbf{AB} = \mathbf{I}$, find \mathbf{A} .

17. Find \mathbf{Y} if $\mathbf{Y} \begin{pmatrix} -2 & 0 \\ 3 & 1 \end{pmatrix} = \begin{pmatrix} 1 & 0 \\ 0 & 1 \end{pmatrix}$.

18. If $\begin{pmatrix} 2 & -3 \\ 0 & 4 \end{pmatrix} + \mathbf{X} = \begin{pmatrix} 1 & 0 \\ 0 & 1 \end{pmatrix}$, find \mathbf{X} .

19. Find \mathbf{B} if $\mathbf{A} = \begin{pmatrix} 2 & -2 \\ -1 & 3 \end{pmatrix}$ and $\mathbf{AB} = \begin{pmatrix} 4 & -2 \\ 0 & 7 \end{pmatrix}$.

20. If $\begin{pmatrix} 3 & -3 \\ 2 & 5 \end{pmatrix} - \mathbf{X} = \begin{pmatrix} 1 & 0 \\ 0 & 1 \end{pmatrix}$, find \mathbf{X} .

21. Find \mathbf{M} if $\begin{pmatrix} 1 & 1 \\ -2 & 1 \end{pmatrix} \mathbf{M} = 2 \begin{pmatrix} 1 & 0 \\ 0 & 1 \end{pmatrix}$.

22. $\mathbf{A} = \begin{pmatrix} 2 & -3 \\ 0 & 1 \end{pmatrix}$ and $\mathbf{B} = \begin{pmatrix} 1 & -1 \\ -1 & 3 \end{pmatrix}$.

Find: (a) \mathbf{AB} (b) \mathbf{A}^{-1} (c) \mathbf{B}^{-1} Show that $(\mathbf{AB})^{-1} = \mathbf{B}^{-1}\mathbf{A}^{-1}$.

23. If $\mathbf{M} = \begin{pmatrix} 3 & 1 \\ 2 & -1 \end{pmatrix}$ and $\mathbf{MN} = \begin{pmatrix} 7 & -9 \\ -2 & -6 \end{pmatrix}$, find \mathbf{N} .

24. $\mathbf{A} = \begin{pmatrix} 2 & 1 \\ 1 & 1 \end{pmatrix}$; $\mathbf{C} = \begin{pmatrix} 11 \\ 7 \end{pmatrix}$. If \mathbf{B} is a (2×1) matrix such that $\mathbf{AB} = \mathbf{C}$, find \mathbf{B} .

25. Find x if the determinant of $\begin{pmatrix} x & 3 \\ 1 & 2 \end{pmatrix}$ is

(a) 5

(b) -1

(c) 0

26. If the matrix $\begin{pmatrix} 1 & -2 \\ x & 4 \end{pmatrix}$ has no inverse, what is the value of x ?

27. The elements of a (2×2) matrix consist of four different numbers. Find the largest possible value of the determinant of this matrix if the numbers are:

(a) 1, 3, 5, 9

(b) -1, 2, 3, 4

9.3 Simple transformations

Reflection

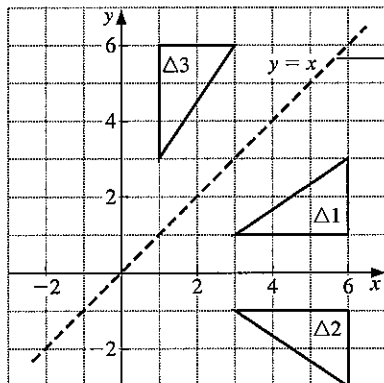

Remember
You must describe a mirror line fully.

$\Delta 2$ is the image of $\Delta 1$ after reflection in the x -axis.
 $\Delta 3$ is the image of $\Delta 1$ after reflection in the line $y = x$.

Exercise 3

In questions 1 to 6 draw the object and its image after reflection in the broken line.

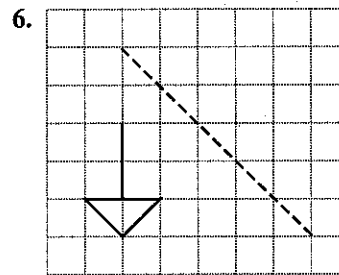
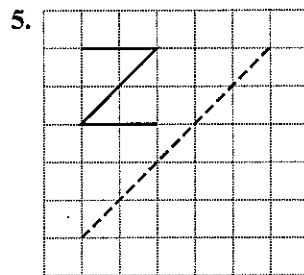
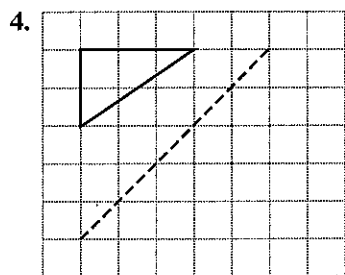
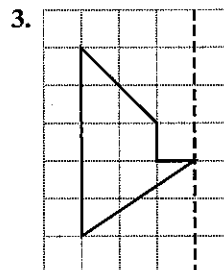
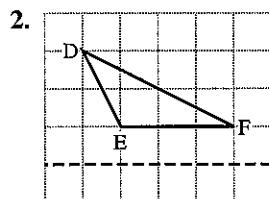
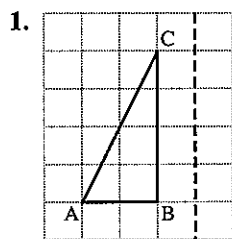

In questions 7, 8, 9 draw the image of the given shape after reflection in line M_1 and then reflect this new shape in line M_2 .

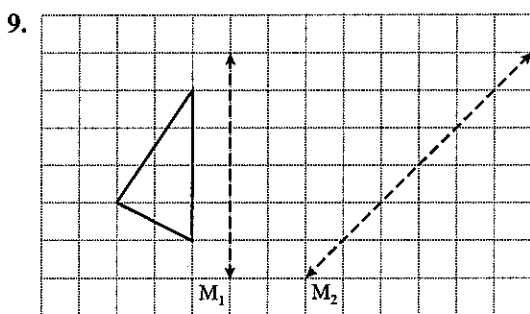
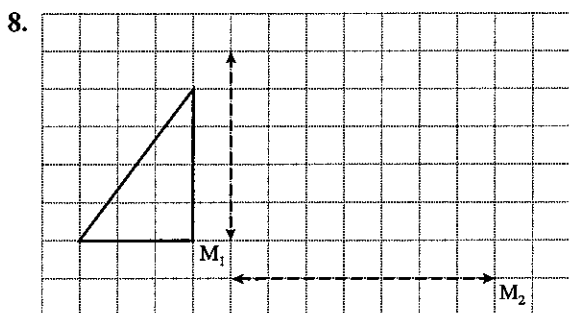
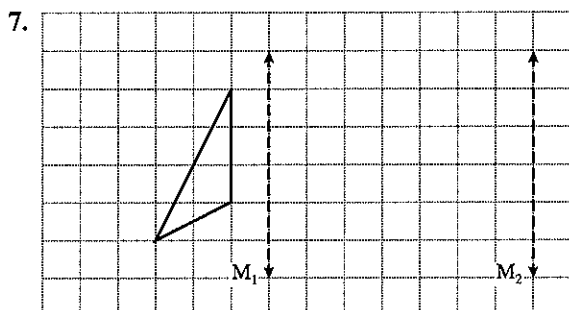

Exercise 4

For each question draw x - and y -axes with values from -8 to 8 .

1. (a) Draw the triangle ABC at $A(6, 8)$, $B(2, 8)$, $C(2, 6)$. Draw the lines $y = 2$ and $y = x$.
- (b) Draw the image of $\triangle ABC$ after reflection in:
 - (i) the y -axis. Label it $\triangle 1$.
 - (ii) the line $y = 2$. Label it $\triangle 2$.
 - (iii) the line $y = x$. Label it $\triangle 3$.
- (c) Write down the coordinates of the image of point A in each case.

2. (a) Draw the triangle DEF at $D(-6, 8)$, $E(-2, 8)$, $F(-2, 6)$. Draw the lines $x = 1$, $y = x$, $y = -x$.
- (b) Draw the image of $\triangle DEF$ after reflection in:
- the line $x = 1$. Label it $\triangle 1$.
 - the line $y = x$. Label it $\triangle 2$.
 - the line $y = -x$. Label it $\triangle 3$.
- (c) Write down the coordinates of the image of point D in each case.
3. (a) Draw the triangle ABC at $A(5, 1)$, $B(8, 1)$, $C(8, 3)$. Draw the lines $x + y = 4$, $y = x - 3$, $x = 2$.
- (b) Draw the image of $\triangle ABC$ after reflection in:
- the line $x + y = 4$. Label it $\triangle 1$.
 - the line $y = x - 3$. Label it $\triangle 2$.
 - the line $x = 2$. Label it $\triangle 3$.
- (c) Write down the coordinates of the image of point A in each case.
4. (a) Draw and label the following triangles:
- $\triangle 1: (3, 3), (3, 6), (1, 6)$
 $\triangle 2: (3, -1), (3, -4), (1, -4)$
 $\triangle 3: (3, 3), (6, 3), (6, 1)$
 $\triangle 4: (-6, -1), (-6, -3), (-3, -3)$
 $\triangle 5: (-6, 5), (-6, 7), (-3, 7)$
- (b) Find the equation of the mirror line for the reflection:
- $\triangle 1$ onto $\triangle 2$
 - $\triangle 1$ onto $\triangle 3$
 - $\triangle 1$ onto $\triangle 4$
 - $\triangle 4$ onto $\triangle 5$
5. (a) Draw $\triangle 1$ at $(3, 1), (7, 1), (7, 3)$.
- Reflect $\triangle 1$ in the line $y = x$ onto $\triangle 2$.
 - Reflect $\triangle 2$ in the x-axis onto $\triangle 3$.
 - Reflect $\triangle 3$ in the line $y = -x$ onto $\triangle 4$.
 - Reflect $\triangle 4$ in the line $x = 2$ onto $\triangle 5$.
 - Write down the coordinates of $\triangle 5$.
6. (a) Draw $\triangle 1$ at $(2, 6), (2, 8), (6, 6)$.
- Reflect $\triangle 1$ in the line $x + y = 6$ onto $\triangle 2$.
 - Reflect $\triangle 2$ in the line $x = 3$ onto $\triangle 3$.
 - Reflect $\triangle 3$ in the line $x + y = 6$ onto $\triangle 4$.
 - Reflect $\triangle 4$ in the line $y = x - 8$ onto $\triangle 5$.
 - Write down the coordinates of $\triangle 5$.

Rotation

Example

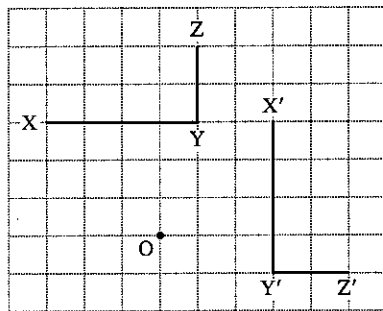

The letter L has been rotated through 90° clockwise about the centre O. The angle, direction, and centre are needed to fully describe a rotation.

We say that the object *maps* onto the image. Here,

- X maps onto X'
- Y maps onto Y'
- Z maps onto Z'

In this work, a clockwise rotation is *negative* and an anticlockwise rotation is *positive*: in this example, the letter L has been rotated through -90° . The angle, the direction, and the centre of rotation can be found using tracing paper and a sharp pencil placed where you think the centre of rotation is.

For more accurate work, draw the perpendicular bisector of the line joining two corresponding points, e.g. Y and Y' . Repeat for another pair of corresponding points. The centre of rotation is at the intersection of the two perpendicular bisectors.

Exercise 5

In questions 1 to 4 draw the object and its image under the rotation given. Take O as the centre of rotation in each case.

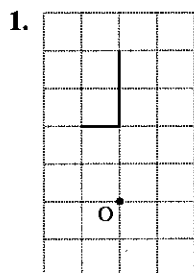

90° clockwise

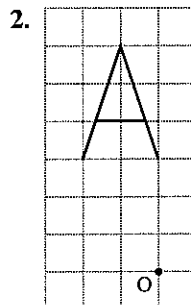

90° anticlockwise

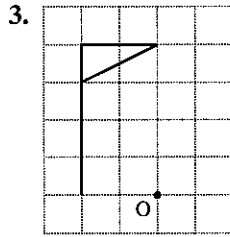

180°

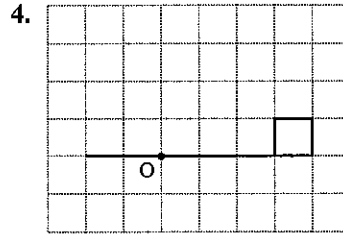

90° clockwise

In questions 5 to 8, copy the diagram on squared paper and find the angle, the direction, and the centre of the rotation.

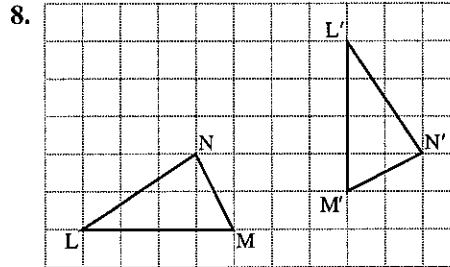
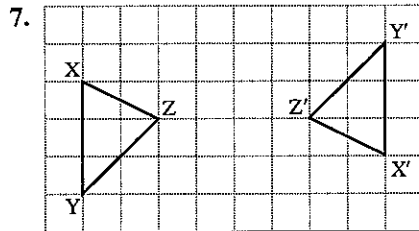
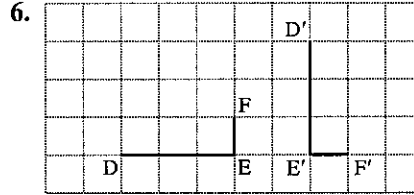
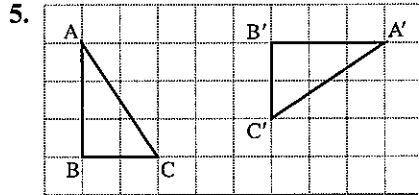

Exercise 6

For all questions draw x - and y -axes for values from -8 to $+8$.

1. (a) Draw the object triangle ABC at A(1, 3), B(1, 6), C(3, 6), rotate ABC through 90° clockwise about (0, 0), mark A'B'C'.
- (b) Draw the object triangle DEF at D(3, 3), E(6, 3), F(6, 1), rotate DEF through 90° clockwise about (0, 0), mark D'E'F'.
- (c) Draw the object triangle PQR at P(-4, 7), Q(-4, 5), R(-1, 5), rotate PQR through 90° anticlockwise about (0, 0), mark P'Q'R'.

2. (a) Draw $\Delta 1$ at (1, 4), (1, 7), (3, 7).
- (b) Draw the images of $\Delta 1$ under the following rotations:
 - (i) 90° clockwise, centre (0, 0). Label it $\Delta 2$.
 - (ii) 180°, centre (0, 0). Label it $\Delta 3$.
 - (iii) 90° anticlockwise, centre (0, 0). Label it $\Delta 4$.

3. (a) Draw triangle PQR at P(1, 2), Q(3, 5), R(6, 2).
- (b) Find the image of PQR under the following rotations:
 - (i) 90° anticlockwise, centre (0, 0); label the image P'Q'R'
 - (ii) 90° clockwise, centre (-2, 2); label the image P''Q''R''
 - (iii) 180°, centre (1, 0); label the image P*Q*R*.
- (c) Write down the coordinates of P', P'', P*.



4. (a) Draw $\Delta 1$ at $(1, 2), (1, 6), (3, 5)$.
 (b) Rotate $\Delta 1$ 90° clockwise, centre $(1, 2)$ onto $\Delta 2$.
 (c) Rotate $\Delta 2$ 180° , centre $(2, -1)$ onto $\Delta 3$.
 (d) Rotate $\Delta 3$ 90° clockwise, centre $(2, 3)$ onto $\Delta 4$.
 (e) Write down the coordinates of $\Delta 4$.
5. (a) Draw and label the following triangles:
 $\Delta 1: (3, 1), (6, 1), (6, 3)$
 $\Delta 2: (-1, 3), (-1, 6), (-3, 6)$
 $\Delta 3: (1, 1), (-2, 1), (-2, -1)$
 $\Delta 4: (3, -1), (3, -4), (5, -4)$
 $\Delta 5: (4, 4), (1, 4), (1, 2)$
- (b) Describe fully the following rotations:
 (i) $\Delta 1$ onto $\Delta 2$ (ii) $\Delta 1$ onto $\Delta 3$
 (iii) $\Delta 1$ onto $\Delta 4$ (iv) $\Delta 1$ onto $\Delta 5$
 (v) $\Delta 5$ onto $\Delta 4$ (vi) $\Delta 3$ onto $\Delta 2$
6. (a) Draw $\Delta 1$ at $(4, 7), (8, 5), (8, 7)$.
 (b) Rotate $\Delta 1$ 90° clockwise, centre $(4, 3)$ onto $\Delta 2$.
 (c) Rotate $\Delta 2$ 180° , centre $(5, -1)$ onto $\Delta 3$.
 (d) Rotate $\Delta 3$ 90° anticlockwise, centre $(0, -8)$ onto $\Delta 4$.
 (e) Describe fully the following rotations:
 (i) $\Delta 4$ onto $\Delta 1$
 (ii) $\Delta 4$ onto $\Delta 2$

Translation

The triangle ABC below has been transformed onto the triangle A'B'C' by a *translation*.

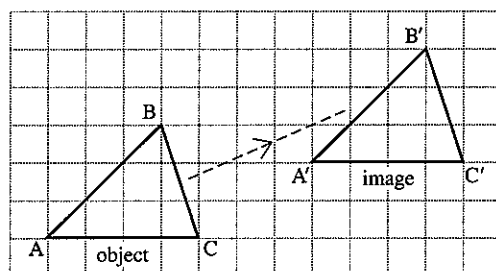

Here the translation is 7 squares to the right and 2 squares up the page. The translation can be described by a column vector.

In this case the translation is $\begin{pmatrix} 7 \\ 2 \end{pmatrix}$.

Exercise 7

1. Make a copy of the diagram below and write down the column vector for each of the following translations:

- | | |
|--------------|---------------|
| (a) D onto A | (b) B onto F |
| (c) E onto A | (d) A onto C |
| (e) E onto C | (f) C onto B |
| (g) F onto E | (h) B onto C. |

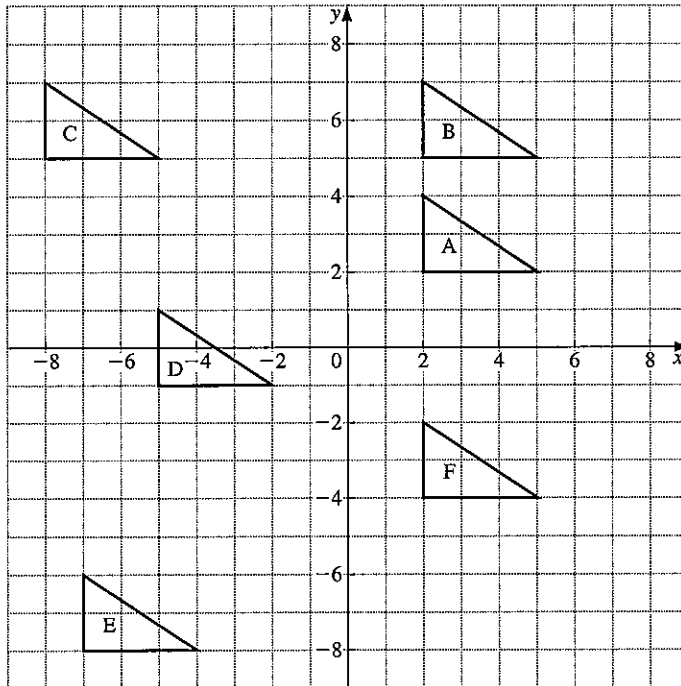

For questions 2 to 11 draw x and y axes with values from -8 to 8 . Draw object triangle ABC at $A(-4, -1)$, $B(-4, 1)$, $C(-1, -1)$ and shade it.

Draw the image of ABC under the translations described by the vectors below. For each question, write down the new coordinates of point C.

- | | | | |
|--|--|---|--|
| 2. $\begin{pmatrix} 6 \\ 3 \end{pmatrix}$ | 3. $\begin{pmatrix} 6 \\ 7 \end{pmatrix}$ | 4. $\begin{pmatrix} 9 \\ -4 \end{pmatrix}$ | 5. $\begin{pmatrix} 1 \\ 7 \end{pmatrix}$ |
| 6. $\begin{pmatrix} 5 \\ -6 \end{pmatrix}$ | 7. $\begin{pmatrix} -2 \\ 5 \end{pmatrix}$ | 8. $\begin{pmatrix} -2 \\ -4 \end{pmatrix}$ | 9. $\begin{pmatrix} 0 \\ -7 \end{pmatrix}$ |
| 10. $\begin{pmatrix} 3 \\ 1 \end{pmatrix}$ followed by $\begin{pmatrix} 3 \\ 2 \end{pmatrix}$ | | | |
| 11. $\begin{pmatrix} -2 \\ 0 \end{pmatrix}$ followed by $\begin{pmatrix} 0 \\ 3 \end{pmatrix}$ followed by $\begin{pmatrix} 1 \\ -1 \end{pmatrix}$ | | | |

Enlargement

In the diagram below, the letter T has been enlarged by a scale factor of 2 using the point O as the centre of the enlargement.

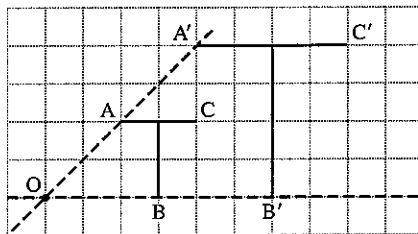

Notice that $OA' = 2 \times OA$
 $OB' = 2 \times OB$

The scale factor and the centre of enlargement are both required to describe an enlargement.

Example 1

Draw the image of triangle ABC under an enlargement scale factor of $\frac{1}{2}$ using O as centre of enlargement.

- Draw lines through OA, OB and OC.
- Mark A' so that $OA' = \frac{1}{2}OA$
 Mark B' so that $OB' = \frac{1}{2}OB$
 Mark C' so that $OC' = \frac{1}{2}OC$.
- Join $A'B'C'$ as shown.

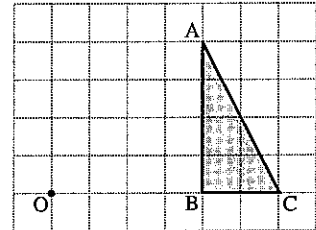

Remember always to measure the lengths from O, not from A, B, or C.

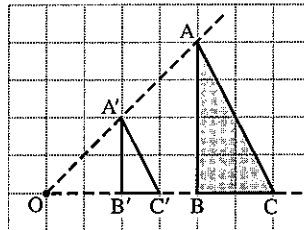

Example 2

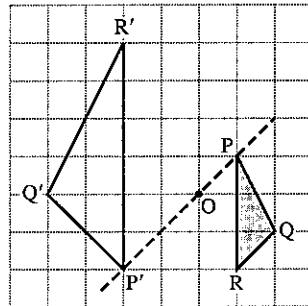

$P'Q'R'$ is the image of PQR after enlargement with scale factor -2 and centre O. Notice that P' and P are on opposite sides of point O. Similarly Q' and Q , R' and R .

Exercise 8

In questions 1 to 6 copy the diagram and draw an enlargement using the centre O and the scale factor given.

1. Scale factor 2

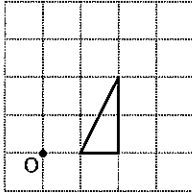

2. Scale factor 3

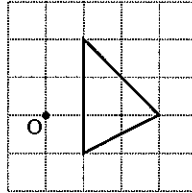

3. Scale factor 3

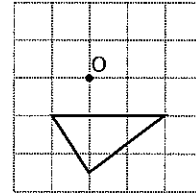

4. Scale factor -2

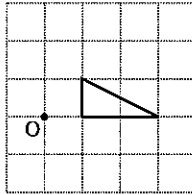

5. Scale factor -3

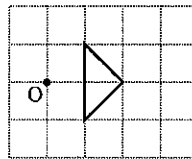
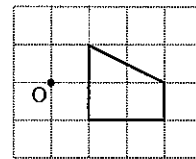
6. Scale factor $1\frac{1}{2}$ 

Answer questions 7 to 19 on graph paper taking x and y from 0 to 15. The vertices of the object are given in coordinate form.

In questions 7 to 10, enlarge the object with the centre of enlargement and scale factor indicated.

	<i>object</i>	<i>centre</i>	<i>scale factor</i>
7.	(2, 4) (4, 2) (5, 5)	(0, 0)	+2
8.	(2, 4) (4, 2) (5, 5)	(1, 2)	+2
9.	(1, 1) (4, 2) (2, 3)	(1, 1)	+3
10.	(4, 4) (7, 6) (9, 3)	(7, 4)	+2

In questions 11 to 14 plot the object and image and find the centre of enlargement and the scale factor.

11.	object A(2, 1), B(5, 1), C(3, 3) image A'(2, 1), B'(11, 1), C'(5, 7)	12.	object A(2, 5), B(9, 3), C(5, 9) image A'(6 $\frac{1}{2}$, 7), B'(10, 6), C'(8, 9)
13.	object A(2, 2), B(4, 4), C(2, 6) image A'(11, 8), B'(7, 4), C'(11, 0)	14.	object A(0, 6), B(4, 6), C(3, 0) image A'(12, 6), B'(8, 6), C'(9, 12)

In questions 15 to 19 enlarge the object using the centre of enlargement and scale factor indicated.

	<i>object</i>	<i>centre</i>	<i>S.F.</i>
15.	(1, 2), (13, 2), (1, 10)	(0, 0)	$+\frac{1}{2}$
16.	(5, 10), (5, 7), (11, 7)	(2, 1)	$+\frac{1}{3}$
17.	(7, 3), (9, 3), (7, 8)	(5, 5)	-1
18.	(1, 1), (3, 1), (3, 2)	(4, 3)	-2
19.	(9, 2), (14, 2), (14, 6)	(7, 4)	$-\frac{1}{2}$

The next exercise contains questions involving the four basic transformations: reflection, rotation, translation, enlargement.

Exercise 9

1. (a) Copy the diagram below.

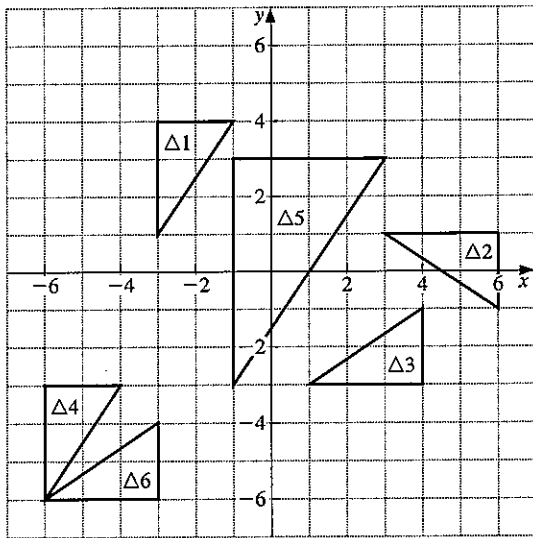

(b) Describe fully the following transformations:

- (i) $\Delta 1 \rightarrow \Delta 2$
- (ii) $\Delta 1 \rightarrow \Delta 3$
- (iii) $\Delta 4 \rightarrow \Delta 1$
- (iv) $\Delta 1 \rightarrow \Delta 5$
- (v) $\Delta 3 \rightarrow \Delta 6$
- (vi) $\Delta 6 \rightarrow \Delta 4$

2. Plot and label the following triangles:

- $\Delta 1 : (-5, -5), (-1, -5), (-1, -3)$
- $\Delta 2 : (1, 7), (1, 3), (3, 3)$
- $\Delta 3 : (3, -3), (7, -3), (7, -1)$
- $\Delta 4 : (-5, -5), (-5, -1), (-3, -1)$
- $\Delta 5 : (1, -6), (3, -6), (3, -5)$
- $\Delta 6 : (-3, 3), (-3, 7), (-5, 7)$

Describe fully the following transformations:

- (a) $\Delta 1 \rightarrow \Delta 2$
- (b) $\Delta 1 \rightarrow \Delta 3$
- (c) $\Delta 1 \rightarrow \Delta 4$
- (d) $\Delta 1 \rightarrow \Delta 5$
- (e) $\Delta 1 \rightarrow \Delta 6$
- (f) $\Delta 5 \rightarrow \Delta 3$
- (g) $\Delta 2 \rightarrow \Delta 3$

3. Plot and label the following triangles:

- $\Delta 1 : (-3, -6), (-3, -2), (-5, -2)$
- $\Delta 2 : (-5, -1), (-5, -7), (-8, -1)$
- $\Delta 3 : (-2, -1), (2, -1), (2, 1)$
- $\Delta 4 : (6, 3), (2, 3), (2, 5)$
- $\Delta 5 : (8, 4), (8, 8), (6, 8)$
- $\Delta 6 : (-3, 1), (-3, 3), (-4, 3)$

Describe fully the following transformations:

- (a) $\Delta 1 \rightarrow \Delta 2$
- (b) $\Delta 1 \rightarrow \Delta 3$
- (c) $\Delta 1 \rightarrow \Delta 4$
- (d) $\Delta 1 \rightarrow \Delta 5$
- (e) $\Delta 1 \rightarrow \Delta 6$
- (f) $\Delta 3 \rightarrow \Delta 5$
- (g) $\Delta 6 \rightarrow \Delta 2$

9.4 Combined transformations

It is convenient to denote transformations by a symbol.

Let **A** denote 'reflection in line $x = 3$ ' and

B denote 'translation $\begin{pmatrix} 2 \\ 1 \end{pmatrix}$ '.

Perform **A** on $\triangle 1$.

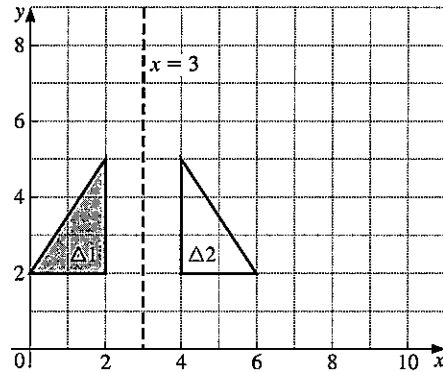

Figure 1

$\triangle 2$ is the image of $\triangle 1$ under the reflection in $x = 3$

i.e. $A(\triangle 1) = \triangle 2$

$A(\triangle 1)$ means 'perform the transformation **A** on triangle $\triangle 1$ '

Perform **B** on $\triangle 2$.

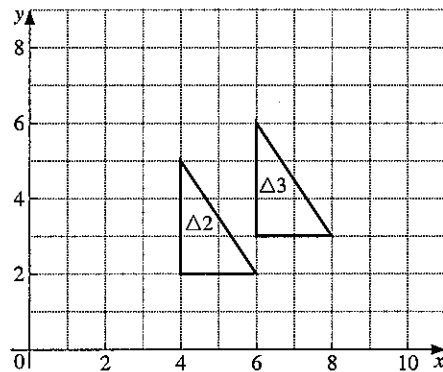

Figure 2

From Figure 2 we can see that

$B(\triangle 2) = \triangle 3$

The effect of going from $\triangle 1$ to $\triangle 3$ may be written

$BA(\triangle 1) = \triangle 3$

It is very important to notice that $BA(\triangle 1)$ means do **A** first and then **B**.

Repeated transformations

$XX(P)$ means 'perform transformation X on P and then perform X on the image'.

It may be written $X^2(P)$

Similarly $TTT(P) = T^3(P)$.

Inverse transformations

If translation T has vector $\begin{pmatrix} 3 \\ -2 \end{pmatrix}$, the translation which has the opposite effect has vector $\begin{pmatrix} -3 \\ 2 \end{pmatrix}$. This is written T^{-1} .

If rotation R denotes 90° clockwise rotation about $(0, 0)$, then R^{-1} denotes 90° anticlockwise rotation about $(0, 0)$.

The *inverse* of a transformation is the transformation which takes the *image* back to the object.

Note:

For all reflections, the inverse is the same reflection.

e.g. if X is reflection in $x = 0$, then X^{-1} is also reflection in $x = 0$.

The symbol T^{-3} means $(T^{-1})^3$ i.e. perform T^{-1} three times.

Exercise 10

Draw x - and y -axes with values from -8 to $+8$ and plot the point $P(3, 2)$.

R denotes 90° clockwise rotation about $(0, 0)$;

X denotes reflection in $x = 0$.

H denotes 180° rotation about $(0, 0)$;

T denotes translation $\begin{pmatrix} 3 \\ 2 \end{pmatrix}$.

For each question, write down the coordinates of the final image of P .

- | | | | |
|------------------|--------------------|--------------------|-----------------|
| 1. $R(P)$ | 2. $TR(P)$ | 3. $T(P)$ | 4. $RT(P)$ |
| 5. $TH(P)$ | 6. $XT(P)$ | 7. $HX(P)$ | 8. $XX(P)$ |
| 9. $R^{-1}(P)$ | 10. $T^{-1}(P)$ | 11. $X^3(P)$ | 12. $T^{-2}(P)$ |
| 13. $R^2(P)$ | 14. $T^{-1}R^2(P)$ | 15. $THX(P)$ | 16. $R^3(P)$ |
| 17. $TX^{-1}(P)$ | 18. $T^3X(P)$ | 19. $T^2H^{-1}(P)$ | 20. $XTH(P)$ |

Exercise 11

In this exercise, transformations **A**, **B**, ... **H**, are as follows:

A denotes reflection in $x = 2$

B denotes 180° rotation, centre $(1, 1)$

C denotes translation $\begin{pmatrix} -6 \\ 2 \end{pmatrix}$

D denotes reflection in $y = x$

E denotes reflection in $y = 0$

F denotes translation $\begin{pmatrix} 4 \\ 3 \end{pmatrix}$

G denotes 90° rotation clockwise, centre $(0, 0)$

H denotes enlargement, scale factor $+\frac{1}{2}$, centre $(0, 0)$

Draw x - and y -axes with values from -8 to $+8$.

- Draw triangle LMN at $L(2, 2)$, $M(6, 2)$, $N(6, 4)$.
Find the image of LMN under the following combinations of transformations. Write down the coordinates of the image of point L in each case:
(a) **CA**(LMN) (b) **ED**(LMN) (c) **DB**(LMN)
(d) **BE**(LMN) (e) **EB**(LMN)
- Draw triangle PQR at $P(2, 2)$, $Q(6, 2)$, $R(6, 4)$.
Find the image of PQR under the following combinations of transformations. Write down the coordinates of the image of point P in each case:
(a) **AF**(PQR) (b) **CG**(PQR)
(c) **AG**(PQR) (d) **HE**(PQR)
- Draw triangle XYZ at $X(-2, 4)$, $Y(-2, 1)$, $Z(-4, 1)$. Find the image of XYZ under the following combinations of transformations and state the equivalent single transformation in each case:
(a) **G²E**(XYZ) (b) **CB**(XYZ) (c) **DA**(XYZ)
- Draw triangle OPQ at $O(0, 0)$, $P(0, 2)$, $Q(3, 2)$.
Find the image of OPQ under the following combinations of transformations and state the equivalent single transformation in each case:
(a) **DE**(OPQ) (b) **FC**(OPQ)
(c) **DEC**(OPQ) (d) **DFE**(OPQ)
- Draw triangle RST at $R(-4, -1)$, $S(-2\frac{1}{2}, -2)$, $T(-4, -4)$. Find the image of RST under the following combinations of transformations and state the equivalent single transformation in each case:
(a) **EAG**(RST) (b) **FH**(RST) (c) **GF**(RST)
- Write down the inverses of the transformations **A**, **B**, ... **H**.

7. Draw triangle JKL at $J(-2, 2)$, $K(-2, 5)$, $L(-4, 5)$. Find the image of JKL under the following transformations. Write down the coordinates of the image of point J in each case:
 (a) C^{-1} (b) F^{-1} (c) G^{-1} (d) D^{-1} (e) A^{-1}
8. Draw triangle PQR at $P(-2, 4)$, $Q(-2, 1)$, $R(-4, 1)$. Find the image of PQR under the following combinations of transformations. Write down the coordinates of the image of point P in each case:
 (a) $DF^{-1}(PQR)$ (b) $EC^{-1}(PQR)$ (c) $D^2F(PQR)$
 (d) $GA(PQR)$ (e) $C^{-1}G^{-1}(PQR)$
9. Draw triangle LMN at $L(-2, 4)$, $M(-4, 1)$, $N(-2, 1)$. Find the image of LMN under the following combinations of transformations. Write down the coordinates of the image of point L in each case:
 (a) $HE(LMN)$ (b) $EAG^{-1}(LMN)$
 (c) $EDA(LMN)$ (d) $BG^2E(LMN)$
10. Draw triangle XYZ at $X(1, 2)$, $Y(1, 6)$, $Z(3, 6)$.
 (a) Find the image of XYZ under each of the transformations **BC** and **CB**.
 (b) Describe fully the single transformation equivalent to **BC**.
 (c) Describe fully the transformation **M** such that $MCB = BC$.

9.5 Transformations using matrices

Example 1

Find the image of triangle ABC, with $A(1, 1)$, $B(3, 1)$, $C(3, 2)$, under the transformation represented by the matrix $M = \begin{pmatrix} 1 & 0 \\ 0 & -1 \end{pmatrix}$.

- (a) Write the coordinates of A as a column vector and multiply this vector by M.

$$\begin{pmatrix} M \\ \begin{pmatrix} 1 & 0 \\ 0 & -1 \end{pmatrix} \end{pmatrix} \begin{pmatrix} A \\ \begin{pmatrix} 1 \\ 1 \end{pmatrix} \end{pmatrix} = \begin{pmatrix} A' \\ \begin{pmatrix} 1 \\ -1 \end{pmatrix} \end{pmatrix}$$

A' , the image of A, has coordinates $(1, -1)$.

- (b) Repeat for B and C.

$$\begin{pmatrix} M \\ \begin{pmatrix} 1 & 0 \\ 0 & -1 \end{pmatrix} \end{pmatrix} \begin{pmatrix} B \\ \begin{pmatrix} 3 \\ 1 \end{pmatrix} \end{pmatrix} = \begin{pmatrix} B' \\ \begin{pmatrix} 3 \\ -1 \end{pmatrix} \end{pmatrix}$$

$$\begin{pmatrix} M \\ \begin{pmatrix} 1 & 0 \\ 0 & -1 \end{pmatrix} \end{pmatrix} \begin{pmatrix} C \\ \begin{pmatrix} 3 \\ 2 \end{pmatrix} \end{pmatrix} = \begin{pmatrix} C' \\ \begin{pmatrix} 3 \\ -2 \end{pmatrix} \end{pmatrix}$$

(c) Plot $A'(1, -1)$, $B'(3, -1)$ and $C'(3, -2)$.

The transformation is a reflection in the x -axis.

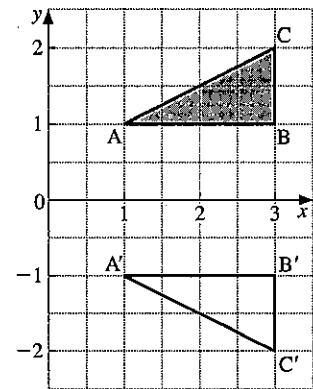

Example 2

Find the image of $L(1, 1)$, $M(1, 3)$, $N(2, 3)$ under the transformation represented by the matrix $\begin{pmatrix} 0 & -1 \\ 1 & 0 \end{pmatrix}$.

A quicker method is to write the three vectors for L , M and N in a single 2×3 matrix, and then perform the multiplication.

$$\begin{pmatrix} 0 & -1 \\ 1 & 0 \end{pmatrix} \begin{pmatrix} L & M & N \\ 1 & 1 & 2 \\ 1 & 3 & 3 \end{pmatrix} = \begin{pmatrix} L' & M' & N' \\ -1 & -3 & -3 \\ 1 & 1 & 2 \end{pmatrix}$$

The transformation is a rotation, $+90^\circ$, centre $(0, 0)$.

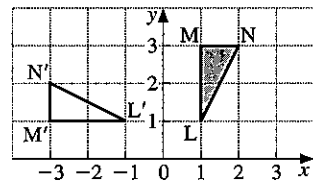

Exercise 12

For questions 1 to 5 draw x - and y -axes with values from -8 to 8 . Do all parts of each question on one graph.

1. Draw the triangle $A(2, 2)$, $B(6, 2)$, $C(6, 4)$. Find its image under the transformations represented by the following matrices:

- (a) $\begin{pmatrix} 0 & -1 \\ 1 & 0 \end{pmatrix}$ (b) $\begin{pmatrix} -1 & 0 \\ 0 & 1 \end{pmatrix}$ (c) $\begin{pmatrix} 1 & 0 \\ 0 & -1 \end{pmatrix}$
 (d) $\begin{pmatrix} 0 & 1 \\ 1 & 0 \end{pmatrix}$ (e) $\begin{pmatrix} \frac{1}{2} & 0 \\ 0 & \frac{1}{2} \end{pmatrix}$

2. Plot the object and image for the following:

- | <i>Object</i> | <i>Matrix</i> |
|--|--|
| (a) $P(4, 2)$, $Q(4, 4)$, $R(0, 4)$ | $\begin{pmatrix} 2 & 0 \\ 0 & 2 \end{pmatrix}$ |
| (b) $P(4, 2)$, $Q(4, 4)$, $R(0, 4)$ | $\begin{pmatrix} -\frac{1}{2} & 0 \\ 0 & -\frac{1}{2} \end{pmatrix}$ |
| (c) $A(-6, 8)$, $B(-2, 8)$, $C(-2, 6)$ | $\begin{pmatrix} 0 & -1 \\ -1 & 0 \end{pmatrix}$ |
| (d) $P(4, 2)$, $Q(4, 4)$, $R(0, 4)$ | $\begin{pmatrix} -2 & 0 \\ 0 & -2 \end{pmatrix}$ |

Describe each as a *single* transformation.

3. Draw a trapezium at $K(2, 2)$, $L(2, 5)$, $M(5, 8)$, $N(8, 8)$. Find the image of KLMN under the transformations described by the following matrices:

$$\mathbf{A} = \begin{pmatrix} 1 & 0 \\ 0 & -1 \end{pmatrix} \quad \mathbf{E} = \begin{pmatrix} 0 & -1 \\ -1 & 0 \end{pmatrix}$$

$$\mathbf{B} = \begin{pmatrix} -1 & 0 \\ 0 & 1 \end{pmatrix} \quad \mathbf{F} = \begin{pmatrix} -1 & 0 \\ 0 & -1 \end{pmatrix}$$

$$\mathbf{C} = \begin{pmatrix} 0 & 1 \\ 1 & 0 \end{pmatrix} \quad \mathbf{G} = \begin{pmatrix} 0 & -1 \\ 1 & 0 \end{pmatrix}$$

$$\mathbf{D} = \begin{pmatrix} 0 & 1 \\ -1 & 0 \end{pmatrix} \quad \mathbf{H} = \begin{pmatrix} 1 & 0 \\ 0 & 1 \end{pmatrix}$$

Describe fully each of the eight transformations.

4. (a) Draw a quadrilateral at $A(3, 4)$, $B(4, 0)$, $C(3, 1)$, $D(0, 0)$. Find the image of ABCD under the transformation represented by the matrix $\begin{pmatrix} -2 & 0 \\ 0 & -2 \end{pmatrix}$.
- (b) Find the ratio $\left(\frac{\text{area of image}}{\text{area of object}}\right)$.
5. (a) Draw axes so that both x and y can take values from -2 to $+8$.
- (b) Draw triangle ABC at $A(2, 1)$, $B(7, 1)$, $C(2, 4)$.
- (c) Find the image of ABC under the transformation represented by the matrix $\begin{pmatrix} 1 & -1 \\ 1 & 1 \end{pmatrix}$ and plot the image on the graph.
- (d) The transformation is a rotation followed by an enlargement. Calculate the angle of the rotation and the scale factor of the enlargement.
6. (a) Draw axes so that x can take values from 0 to 15 and y can take values from -6 to $+6$.
- (b) Draw triangle PQR at $P(2, 1)$, $Q(7, 1)$, $R(2, 4)$.
- (c) Find the image of PQR under the transformation represented by the matrix $\begin{pmatrix} 2 & 1 \\ -1 & 2 \end{pmatrix}$ and plot the image on the graph.
- (d) The transformation is a rotation followed by an enlargement. Calculate the angle of the rotation and the scale factor of the enlargement.
7. (a) On graph paper, draw the triangle T whose vertices are $(2, 2)$, $(6, 2)$ and $(6, 4)$.
- (b) Draw the image U of T under the transformation whose matrix is $\begin{pmatrix} 0 & 1 \\ 1 & 0 \end{pmatrix}$.
- (c) Draw the image V of T under the transformation whose matrix is $\begin{pmatrix} 1 & 0 \\ 0 & -1 \end{pmatrix}$.
- (d) Describe the single transformation which would map U onto V.

8. (a) Find the images of the points (1, 0), (2, 1), (3, -1), (-2, 3) under the transformation with matrix $\begin{pmatrix} 1 & 3 \\ 2 & 6 \end{pmatrix}$.
- (b) Show that the images lie on a straight line, and find its equation.
9. The transformation with matrix $\begin{pmatrix} 2 & 3 \\ 6 & 9 \end{pmatrix}$ maps every point in the plane onto a line. Find the equation of the line.
10. Using a scale of 1 cm to one unit in each case draw x - and y -axes, taking values of x from -4 to +6 and values of y from 0 to 12.
- (a) Draw and label the quadrilateral OABC with O(0, 0), A(2, 0), B(4, 2), C(0, 2).
- (b) Find and draw the image of OABC under the transformation whose matrix is \mathbf{R} , where $\mathbf{R} = \begin{pmatrix} 2.4 & -1.8 \\ 1.8 & 2.4 \end{pmatrix}$.
- (c) Calculate, in surd form, the lengths OB and O'B'.
- (d) Calculate the angle AOA'.
- (e) Given that the transformation \mathbf{R} consists of a rotation about O followed by an enlargement, state the angle of the rotation and the scale factor of the enlargement.
11. The matrix $\mathbf{R} = \begin{pmatrix} \cos \theta & -\sin \theta \\ \sin \theta & \cos \theta \end{pmatrix}$ represents a positive rotation of θ° about the origin. Find the matrix which represents a rotation of:
- (a) 90° (b) 180° (c) 30° (d) -90°
 (e) 60° (f) 150° (g) 45° (h) 53.1°
- Confirm your results for parts (a), (e), (h) by applying the matrix to the quadrilateral O(0, 0), A(0, 2), B(4, 2), C(4, 0).
12. Using the matrix \mathbf{R} given in question 11, find the angle of rotation for the following:
- (a) $\begin{pmatrix} 0 & -1 \\ 1 & 0 \end{pmatrix}$ (b) $\begin{pmatrix} 0.8 & -0.6 \\ 0.6 & 0.8 \end{pmatrix}$
 (c) $\begin{pmatrix} 0.5 & 0.866 \\ -0.866 & 0.5 \end{pmatrix}$ (d) $\begin{pmatrix} 0.6 & 0.8 \\ -0.8 & 0.6 \end{pmatrix}$
- Confirm your results by applying each matrix to the quadrilateral O(0, 0), A(0, 2), B(4, 2), C(4, 0).

Exercise 13

1. Draw the rectangle (0, 0), (0, 1), (2, 1), (2, 0) and its image under the following transformations and describe the *single* transformation which each represents:
- (a) $\begin{pmatrix} 0 & 1 \\ 1 & 0 \end{pmatrix} \begin{pmatrix} x \\ y \end{pmatrix} + \begin{pmatrix} 1 \\ -1 \end{pmatrix}$ (b) $\begin{pmatrix} 1 & 0 \\ 0 & -1 \end{pmatrix} \begin{pmatrix} x \\ y \end{pmatrix} + \begin{pmatrix} 0 \\ 2 \end{pmatrix}$
 (c) $\begin{pmatrix} 0 & 1 \\ -1 & 0 \end{pmatrix} \begin{pmatrix} x \\ y \end{pmatrix} + \begin{pmatrix} 4 \\ 0 \end{pmatrix}$ (d) $\begin{pmatrix} 3 & 0 \\ 0 & 3 \end{pmatrix} \begin{pmatrix} x \\ y \end{pmatrix} + \begin{pmatrix} -4 \\ 2 \end{pmatrix}$

2. (a) Draw $L(1, 1)$, $M(3, 3)$, $N(4, 1)$ and its image $L'M'N'$ under the matrix $A = \begin{pmatrix} 1 & 0 \\ 0 & -1 \end{pmatrix}$.
- (b) Find and draw the image of $L'M'N'$ under matrix $B = \begin{pmatrix} 0 & 1 \\ -1 & 0 \end{pmatrix}$ and label it $L''M''N''$.
- (c) Calculate the matrix product BA .
- (d) Find the image of LMN under the matrix BA , and compare with the result of performing A and then B .
3. (a) Draw $P(0, 0)$, $Q(2, 2)$, $R(4, 0)$ and its image $P'Q'R'$ under matrix $A = \begin{pmatrix} 2 & 0 \\ 0 & 2 \end{pmatrix}$.
- (b) Find and draw the image of $P'Q'R'$ under matrix $B = \begin{pmatrix} 1 & 1 \\ 0 & 1 \end{pmatrix}$ and label it $P''Q''R''$.
- (c) Calculate the matrix product BA .
- (d) Find the image of PQR under the matrix BA , and compare with the result of performing A and then B .
4. (a) Draw $L(1, 1)$, $M(3, 3)$, $N(4, 1)$ and its image $L'M'N'$ under matrix $K = \begin{pmatrix} 2 & 0 \\ 0 & 2 \end{pmatrix}$.
Find K^{-1} , the inverse of K , and now find the image of $L'M'N'$ under K^{-1} .
- (b) Repeat part (a) with $K = \begin{pmatrix} 1 & 2 \\ 0 & 1 \end{pmatrix}$.
- (c) Repeat part (a) with $K = \begin{pmatrix} 3 & 0 \\ 0 & 1 \end{pmatrix}$.
5. The image (x', y') of a point (x, y) under a transformation is given by $\begin{pmatrix} x' \\ y' \end{pmatrix} = \begin{pmatrix} 3 & 0 \\ 1 & -2 \end{pmatrix} \begin{pmatrix} x \\ y \end{pmatrix} + \begin{pmatrix} 2 \\ 5 \end{pmatrix}$
- (a) Find the coordinates of the image of the point $(4, 3)$.
- (b) The image of the point (m, n) is the point $(11, 7)$. Write down two equations involving m and n and hence find the values of m and n .
- (c) The image of the point (h, k) is the point $(5, 10)$. Find the values of h and k .
6. Draw $A(0, 2)$, $B(2, 2)$, $C(0, 4)$ and its image under an enlargement, $A'(2, 2)$, $B'(6, 2)$, $C'(2, 6)$.
- (a) What is the centre of enlargement?
- (b) Find the image of ABC under an enlargement, scale factor 2, centre $(0, 0)$.
- (c) Find the translation which maps this image onto $A'B'C'$.
- (d) What is the matrix X and vector v which represents an enlargement scale factor 2, centre $(-2, 2)$?

7. Draw $A(0, 1)$, $B(1, 1)$, $C(1, 3)$ and its image under a reflection $A'(4, 1)$, $B'(3, 1)$, $C'(3, 3)$.
- What is the equation of the mirror line?
 - Find the image of ABC under a reflection in the line $x = 0$.
 - Find the translation which maps this image onto $A'B'C'$.
 - What is the matrix X and vector v which represents a reflection in the line $x = 2$?
8. Use the same approach as in questions 6 and 7 to find the matrix X and vector v which represents each of the following transformations. (Start by drawing an object and its image under the transformation.)
- Enlargement scale factor 2, centre $(1, 3)$
 - Enlargement scale factor 2, centre $(\frac{1}{2}, 1)$
 - Reflection in $y = x + 3$
 - Rotation 180° , centre $(1\frac{1}{2}, 2\frac{1}{2})$
 - Reflection in $y = 1$
 - Rotation -90° , centre $(2, -2)$

Describing a transformation using base vectors

It is possible to describe a transformation in matrix form by

considering the effect on the *base vectors* $\begin{pmatrix} 1 \\ 0 \end{pmatrix}$ and $\begin{pmatrix} 0 \\ 1 \end{pmatrix}$.

We will let $\begin{pmatrix} 1 \\ 0 \end{pmatrix}$ be I and $\begin{pmatrix} 0 \\ 1 \end{pmatrix}$ be J .

The *columns* of a matrix give us the images of I and J after the transformation.

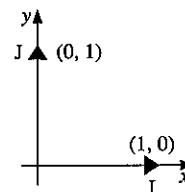

Example

Describe the transformation with matrix $\begin{pmatrix} 0 & 1 \\ -1 & 0 \end{pmatrix}$.

Column $\begin{pmatrix} 0 \\ -1 \end{pmatrix}$ represents I' (the image of I).

Column $\begin{pmatrix} 1 \\ 0 \end{pmatrix}$ represents J' (the image of J)

$$\begin{matrix} I' & J' \\ \begin{pmatrix} 0 & 1 \\ -1 & 0 \end{pmatrix} \end{matrix}$$

Draw I , J , I' and J' on a diagram.

Clearly both I and J have been rotated 90° clockwise about the origin. $\begin{pmatrix} 0 & 1 \\ -1 & 0 \end{pmatrix}$ represents a rotation of -90° .

This method can be used to describe a reflection, rotation, enlargement, shear or stretch in which the origin remains fixed.

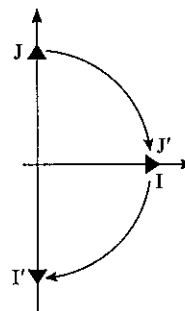

Exercise 14

In questions 1 to 12, use base vectors to describe the transformation represented by each matrix.

1. $\begin{pmatrix} 0 & -1 \\ 1 & 0 \end{pmatrix}$

2. $\begin{pmatrix} -1 & 0 \\ 0 & 1 \end{pmatrix}$

3. $\begin{pmatrix} 0 & -1 \\ -1 & 0 \end{pmatrix}$

4. $\begin{pmatrix} 0 & 1 \\ 1 & 0 \end{pmatrix}$

5. $\begin{pmatrix} 2 & 0 \\ 0 & 2 \end{pmatrix}$

6. $\begin{pmatrix} \frac{1}{2} & 0 \\ 0 & \frac{1}{2} \end{pmatrix}$

7. $\begin{pmatrix} -2 & 0 \\ 0 & -2 \end{pmatrix}$

8. $\begin{pmatrix} \frac{1}{2} & 0 \\ 0 & -\frac{1}{2} \end{pmatrix}$

In questions 9 to 18, use base vectors to write down the matrix which represents each of the transformations:

9. Rotation $+90^\circ$ about $(0, 0)$
10. Reflection in $y = x$
11. Reflection in y -axis
12. Rotation 180° about $(0, 0)$
13. Enlargement, centre $(0, 0)$, scale factor 3
14. Reflection in $y = -x$
15. Enlargement, centre $(0, 0)$, scale factor -2
16. Reflection in x -axis
17. Rotation -90° about $(0, 0)$
18. Enlargement, centre $(0, 0)$, scale factor $\frac{1}{2}$

Shear

Figure 1 shows a pack of cards stacked neatly into a pile. Figure 2 shows the same pack after a *shear* has been performed.



Note:

- (a) the card AB, at the bottom has not moved (we say the line AB is invariant).
- (b) the distance moved by any card depends on its distance from the base card.
The card at the top moves twice as far as the card in the middle.

The area is the same after a shear.

Stretch

The rectangle ABCD has been *stretched* in the direction of the y -axis so that $A'B'$ is twice AB.

A stretch is fully described if we know:

- (a) the direction of the stretch and the invariant line.
- (b) the ratio of corresponding lengths.

The matrix $\begin{pmatrix} 1 & 0 \\ 0 & k \end{pmatrix}$ represents a stretch parallel to the y -axis, invariant line $y = 0$, where the ratio of corresponding lengths is k .

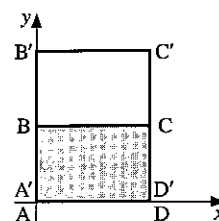

Exercise 15

1. In the diagram, OABC has been mapped onto OA'B'C by a shear.
What is the invariant line of the shear?

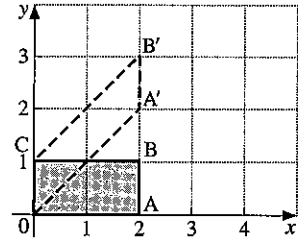

2. Draw axes for values of x from -6 to $+9$ and for values of y from -2 to $+5$.

Find the coordinates of the image of each of the following shapes under the shear

represented by the matrix $\begin{pmatrix} 1 & 2 \\ 0 & 1 \end{pmatrix}$.

Draw each object and image together on a diagram.

- (a) $(0, 0)(0, 3)(2, 3)(2, 0)$ (b) $(0, 0)(-2, 0)(-2, -2)(0, -2)$
 (c) $(0, 0)(2, 2)(3, 0)$ (d) $(1, 1)(1, 3)(3, 3)(3, 1)$

What is the invariant line for this shear?

3. Use base vectors to describe the transformation represented by each matrix:

- (a) $\begin{pmatrix} 3 & 0 \\ 0 & 1 \end{pmatrix}$ (b) $\begin{pmatrix} 1 & 1 \\ 0 & 1 \end{pmatrix}$ (c) $\begin{pmatrix} 1 & 0 \\ 2 & 1 \end{pmatrix}$ (d) $\begin{pmatrix} 1 & 0 \\ 0 & 2 \end{pmatrix}$

In questions 4 to 11, plot the rectangle ABCD at $A(0, 0)$, $B(0, 2)$, $C(3, 2)$, $D(3, 0)$. Find and draw the image of ABCD under the transformation given and describe the transformation fully.

4. $\begin{pmatrix} 2 & 0 \\ 0 & 1 \end{pmatrix}$

5. $\begin{pmatrix} 3 & 0 \\ 0 & 1 \end{pmatrix}$

6. $\begin{pmatrix} 1 & 0 \\ 0 & 2 \end{pmatrix}$

7. $\begin{pmatrix} 1\frac{1}{2} & 0 \\ 0 & 1 \end{pmatrix}$

8. $\begin{pmatrix} 1 & 1 \\ 0 & 1 \end{pmatrix}$

9. $\begin{pmatrix} -2 & 0 \\ 0 & 1 \end{pmatrix}$

10. $\begin{pmatrix} 1 & 0 \\ 0 & 3 \end{pmatrix}$

11. $\begin{pmatrix} \frac{1}{2} & 0 \\ 0 & 1 \end{pmatrix}$

12. (a) Find and draw the image of the square $(0, 0)$, $(1, 1)$, $(0, 2)$, $(-1, 1)$ under the transformation represented by the matrix $\begin{pmatrix} 4 & 3 \\ -3 & -2 \end{pmatrix}$.

(b) Show that the transformation is a shear and find the equation of the invariant line.

13. (a) Find and draw the image of the square $(0, 0)$, $(1, 1)$, $(0, 2)$, $(-1, 1)$ under the shear represented by the matrix $\begin{pmatrix} 0.5 & -0.5 \\ 0.5 & 1.5 \end{pmatrix}$.

(b) Find the equation of the invariant line.

14. Find and draw the image of the square $(0, 0)$, $(1, 0)$, $(1, 1)$, $(0, 1)$ under the transformation represented by the matrix $\begin{pmatrix} 3 & 0 \\ 0 & 2 \end{pmatrix}$.

This transformation is called a two-way stretch.

Revision exercise 9A

1. $\mathbf{A} = \begin{pmatrix} 3 & 2 \\ 1 & 4 \end{pmatrix}$, $\mathbf{B} = \begin{pmatrix} -1 & 3 \\ 0 & 2 \end{pmatrix}$.

Express as a single matrix:

(a) $2\mathbf{A}$ (b) $\mathbf{A} - \mathbf{B}$ (c) $\frac{1}{2}\mathbf{A}$ (d) \mathbf{AB} (e) \mathbf{B}^2

2. Evaluate:

(a) $\begin{pmatrix} -3 & 0 \\ 1 & 2 \end{pmatrix} \begin{pmatrix} 3 & \frac{1}{3} \\ 1 & \frac{1}{2} \end{pmatrix}$ (b) $\begin{pmatrix} 3 \\ 1 \end{pmatrix} (4 \ 2)$

(c) $\begin{pmatrix} 3 & -2 \\ 4 & 1 \end{pmatrix} + 2 \begin{pmatrix} 3 & 0 \\ -1 & -4 \end{pmatrix}$.

3. $\mathbf{A} = \begin{pmatrix} 4 & 2 \\ 1 & 1 \end{pmatrix}$, $\mathbf{B} = (1 \ 5)$, $\mathbf{C} = \begin{pmatrix} -1 \\ 3 \end{pmatrix}$.

(a) Determine \mathbf{BC} and \mathbf{CB} .

(b) If $\mathbf{AX} = \begin{pmatrix} 8 & 20 \\ 3 & 7 \end{pmatrix}$, where \mathbf{X} is a (2×2) matrix, determine \mathbf{X} .

4. Find the inverse of the matrix $\begin{pmatrix} 2 & -1 \\ 3 & 5 \end{pmatrix}$.

5. The determinant of the matrix $\begin{pmatrix} 3 & 2 \\ x & -1 \end{pmatrix}$ is -9 .

Find the value of x and write down the inverse of the matrix.

6. $\mathbf{A} = \begin{pmatrix} 2 & 0 \\ 1 & 2 \end{pmatrix}$; h and k are numbers so that

$$\mathbf{A}^2 = h\mathbf{A} + k\mathbf{I}, \text{ where } \mathbf{I} = \begin{pmatrix} 1 & 0 \\ 0 & 1 \end{pmatrix}.$$

Find the values of h and k .

7. $\mathbf{M} = \begin{pmatrix} a & 1 \\ 1 & -a \end{pmatrix}$.

(a) Find the values of a if $\mathbf{M}^2 = 17 \begin{pmatrix} 1 & 0 \\ 0 & 1 \end{pmatrix}$.

(b) Find the values of a if $|\mathbf{M}| = -10$.

8. Find the coordinates of the image of $(1, 4)$ under:

(a) a clockwise rotation of 90° about $(0, 0)$

(b) a reflection in the line $y = x$

(c) a translation which maps $(5, 3)$ onto $(1, 1)$

14. The matrix $\begin{pmatrix} 0 & -1 \\ 1 & 0 \end{pmatrix}$ represents the transformation **X**.

- (a) Find the image of (5, 2) under **X**.
 (b) Find the image of (-3, 4) under **X**.
 (c) Describe the transformation **X**.

15. Draw x - and y -axes with values from -8 to +8.

Draw triangle A(2, 2), B(6, 2), C(6, 4).

Find the image of ABC under the transformations represented by the matrices:

(a) $\begin{pmatrix} 0 & -1 \\ 1 & 0 \end{pmatrix}$ (b) $\begin{pmatrix} 1 & 0 \\ 0 & -1 \end{pmatrix}$

(c) $\begin{pmatrix} -1 & 0 \\ 0 & -1 \end{pmatrix}$ (d) $\begin{pmatrix} 0 & 1 \\ -1 & 0 \end{pmatrix}$

(e) $\begin{pmatrix} 0 & -1 \\ -1 & 0 \end{pmatrix}$

Describe each transformation.

16. Using base vectors, describe the transformations represented by the following matrices:

(a) $\begin{pmatrix} 0 & 1 \\ 1 & 0 \end{pmatrix}$ (b) $\begin{pmatrix} -1 & 0 \\ 0 & 1 \end{pmatrix}$ (c) $\begin{pmatrix} 3 & 0 \\ 0 & 3 \end{pmatrix}$

17. Using base vectors, write down the matrices which describe the following transformations:

- (a) Rotation 180° , centre (0, 0)
 (b) Reflection in the line $y = 0$
 (c) Enlargement scale factor 4, centre (0, 0)
 (d) Reflection in the line $x = -y$
 (e) Clockwise rotation 90° , centre (0, 0)

18. Transformation **N**, which is given by

$$\begin{pmatrix} x' \\ y' \end{pmatrix} = \begin{pmatrix} 2 & 0 \\ 0 & 2 \end{pmatrix} \begin{pmatrix} x \\ y \end{pmatrix} + \begin{pmatrix} 5 \\ -2 \end{pmatrix},$$

is composed of two single transformations.

- (a) Describe each of the transformations.
 (b) Find the image of the point (3, -1) under **N**.
 (c) Find the image of the point $(-1, \frac{1}{2})$ under **N**.
 (d) Find the point which is mapped by **N** onto the point (7, 4).

19. **A** is the reflection in the line $y = x$.

B is the reflection in the y -axis.

Find the matrix which represents:

- (a) **A** (b) **B** (c) **AB** (d) **BA**

Describe the single transformations **AB** and **BA**.

Examination exercise 9B

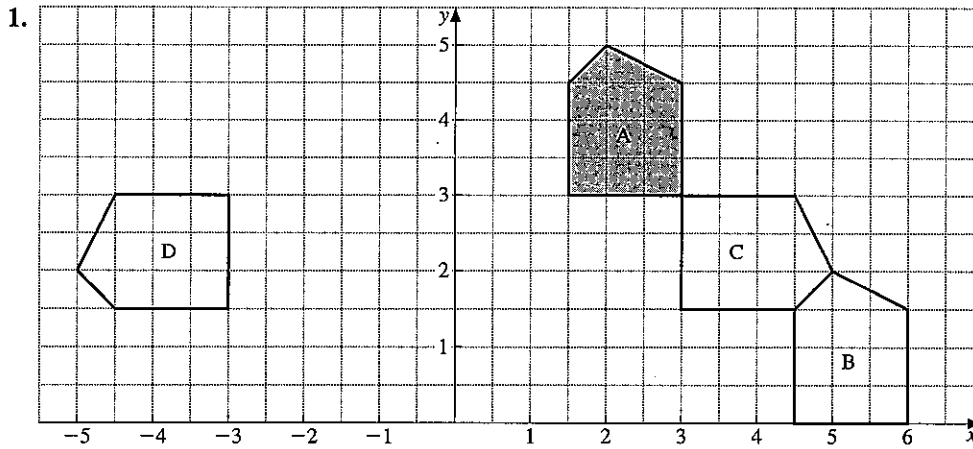

- (a) Describe fully the single transformation which maps the pentagon A onto
 - (i) B (ii) C (iii) D
- (b) Find the matrix of the transformation which maps A onto D.
- (c) Describe the single transformation which maps D onto C.
- (d) Find the matrix of the transformation which maps D onto C.
- (e) Find the equation of the line in which B is reflected onto C.

J 97 4

2. $A = \begin{pmatrix} 1 & 2 \end{pmatrix}$, $B = \begin{pmatrix} -3 \\ 4 \end{pmatrix}$ and $C = \begin{pmatrix} -2 & 5 \\ -3 & 6 \end{pmatrix}$.

- (a) Which one of the following matrix calculations is possible?
 - (i) $A + B$ (ii) AC (iii) BC
- (b) Calculate AB .
- (c) Find C^{-1} , the inverse of C.

J 95 2

3. Answer the whole of this question on a sheet of graph paper.

- (a) Draw x - and y -axes from -5 to 5 using a scale of 1 cm to represent 1 unit on each axis.
 Draw triangle ABC with A(1, 1), B(4, 1) and C(4, 2).
- (b) (i) Draw the image of triangle ABC when it is rotated 90° anticlockwise about the origin. Label this image $A_1B_1C_1$.
- (ii) Triangle $A_1B_1C_1$ is translated by the vector $\begin{pmatrix} 3 \\ 1 \end{pmatrix}$.
 Draw and label this image $A_2B_2C_2$.
- (iii) Describe fully the single transformation which maps triangle ABC onto triangle $A_2B_2C_2$.
- (c) (i) Draw the image of triangle ABC under the transformation represented by the matrix $\begin{pmatrix} 1 & 0 \\ 0 & -2 \end{pmatrix}$. Label this image $A_3B_3C_3$.
- (ii) Describe fully the single transformation which maps triangle ABC onto triangle $A_3B_3C_3$.

N 95 4

4. Answer the whole of this question on a sheet of graph paper.

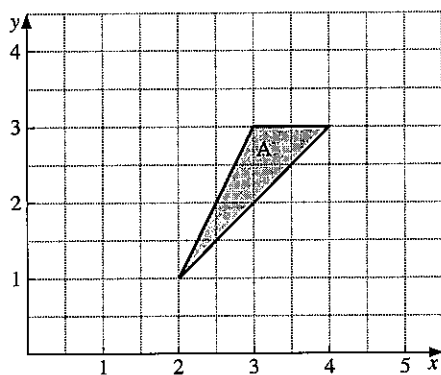

The diagram shows triangle A, with vertices (2, 1), (3, 3) and (4, 3).

- Using a scale of 1 cm to represent 1 unit, draw on your graph paper an x -axis for $-6 \leq x \leq 8$ and a y -axis for $-6 \leq y \leq 8$. Draw triangle A.
- Draw the enlargement of triangle A, centre (0, 0), scale factor 2. Label it B.
- Draw the rotation of triangle A, through 90° anticlockwise about (0, 0). Label it C.
- Draw the reflection of triangle A in the line $y = -1$. Label it D.
- Draw the translation of triangle A by the vector $\begin{pmatrix} -2 \\ -4 \end{pmatrix}$. Label it E.
- (i) A transformation is represented by the matrix $\begin{pmatrix} 0 & 1 \\ 1 & 0 \end{pmatrix}$.

Draw the image of triangle A under this transformation. Label it F.

- Describe fully the single transformation which maps A onto F.
- (i) Describe fully the single transformation which maps F onto C.
(ii) Find the matrix for this transformation. J 95 4

5. Answer the whole of this question on a sheet of graph paper.

Using a scale of 1 cm to represent 1 unit on each axis, draw x - and y -axes from 0 to 16.

- On your grid draw triangle T whose vertices are (2, 2), (2, 4) and (6, 4).
- Triangle S is the image of triangle T under the transformation represented by the matrix $\mathbf{M} = \begin{pmatrix} 1 & 0 \\ 2 & 1 \end{pmatrix}$.
 - Draw and label triangle S on your diagram.
 - Calculate the area of triangle S.
 - Describe fully the single transformation represented by the matrix \mathbf{M} .
- (i) Find \mathbf{M}^{-1} , the inverse of the matrix \mathbf{M} .
(ii) What is the image of triangle S under the transformation represented by \mathbf{M}^{-1} ? N 97 4

6.

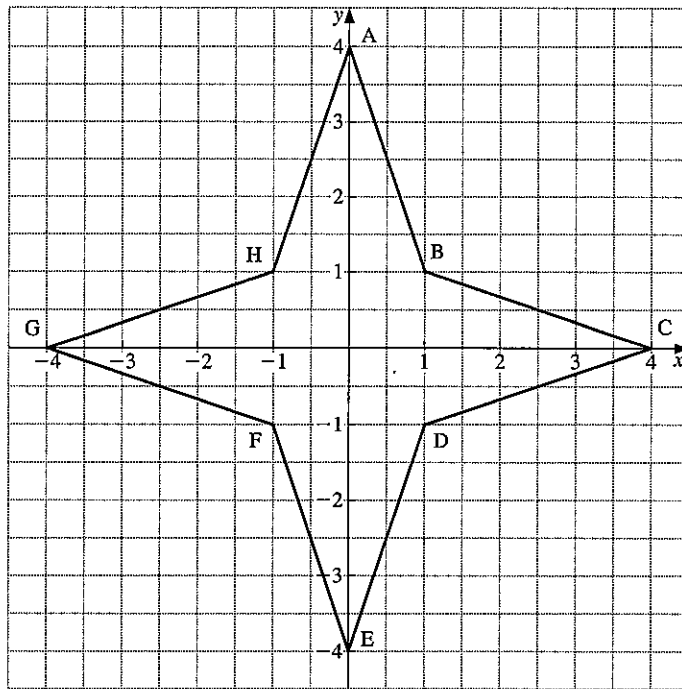

- (a) Describe fully a single transformation which maps:
- both G onto C and H onto B,
 - both G onto D and H onto C,
 - both G onto C and H onto D.
- (b) Write down the new positions of the points G and H when they are:
- rotated 90° clockwise about O,
 - reflected in the line $y = x$.
- (c) The matrix $M = \begin{pmatrix} 0 & -1 \\ 1 & 0 \end{pmatrix}$.
- Describe fully the single transformation represented by M.
 - Write down the new positions of G and H under M.
- (d) The matrix $N = \begin{pmatrix} 4 & -3 \\ -2 & 2 \end{pmatrix}$.
- Find N^{-1} , the inverse of N.
 - Write down the positions of G and H after the transformation represented by NN^{-1} .

J 98 4

7. (a) Multiply $\begin{pmatrix} 5 & 4 \\ -3 & -2 \end{pmatrix} \begin{pmatrix} 2 & 1 & -4 \\ 0 & 3 & 6 \end{pmatrix}$.

(b) Find the inverse of $\begin{pmatrix} 5 & 4 \\ -3 & -2 \end{pmatrix}$.

J 03 2

8. (a) Copy the diagram. Draw the shear of the shaded square with the x -axis invariant and the point $(0, 2)$ mapping onto the point $(3, 2)$.
- (b) Make another copy of the diagram in part (a).
- Draw the one-way stretch of the shaded square with the x -axis invariant and the point $(0, 2)$ mapping onto the point $(0, 6)$.
 - Write down the matrix of this stretch.

J 03 2

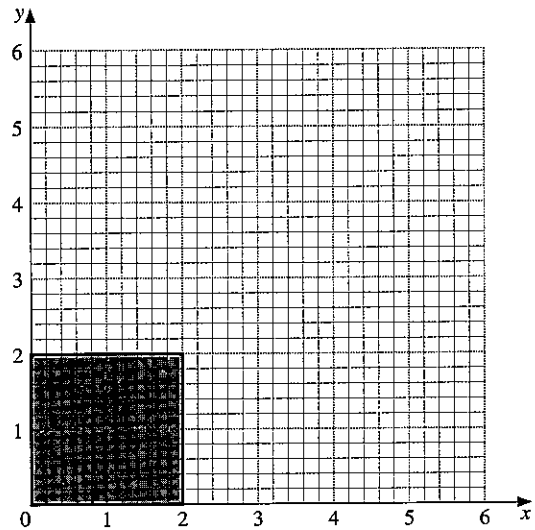

9. (a)

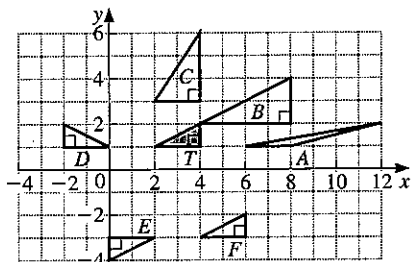

Use one of the letters A, B, C, D, E or F to answer the following questions.

- Which triangle is T mapped onto by a **translation**?
Write down the translation vector.
- Which triangle is T mapped onto by a **reflection**?
Write down the equation of the mirror line.
- Which triangle is T mapped onto by a **rotation**?
Write down the coordinates of the centre of rotation.
- Which triangle is T mapped onto by a **stretch** with the x -axis invariant? Write down the scale factor of the stretch.
- $M = \begin{pmatrix} 1 & 4 \\ 0 & 1 \end{pmatrix}$. Which triangle is T mapped onto by M ?

Write down the name of this transformation.

(b) $P = \begin{pmatrix} 1 & 3 \\ 5 & 7 \end{pmatrix}$, $Q = \begin{pmatrix} -1 & -2 \end{pmatrix}$, $R = \begin{pmatrix} 1 & 2 & 3 \end{pmatrix}$, $S = \begin{pmatrix} -1 \\ 2 \\ 3 \end{pmatrix}$.

Only some of the following matrix operations are possible with matrices P, Q, R and S above.

$PQ, QP, P+Q, PR, RS$

Write down and calculate each matrix operation that is possible.

N 03 4

10 STATISTICS AND PROBABILITY

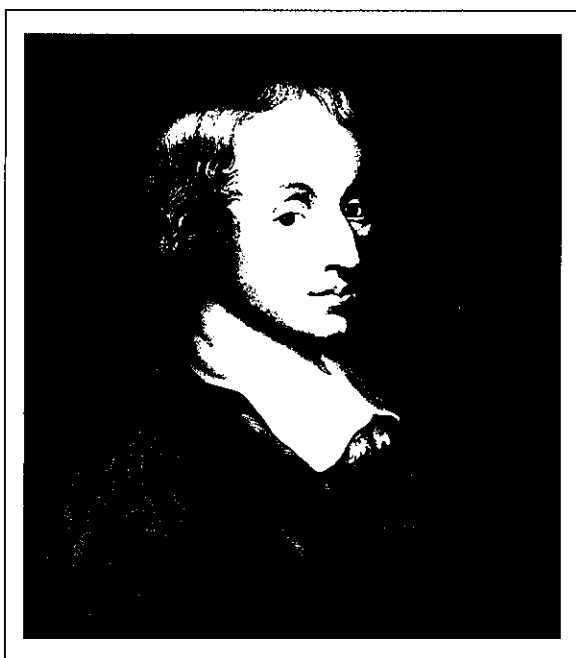

Blaise Pascal (1623–1662) suffered the most appalling ill-health throughout his short life. He is best known for his work with Fermat on probability. This followed correspondence with a gentleman gambler who was puzzled as to why he lost so much in betting on the basis of the appearance of a throw of dice. Pascal's work on probability became of enormous importance and showed for the first time that absolute certainty is not a necessity in mathematics and science. He also studied physics, but his last years were spent in religious meditation and illness.

- 33** Construct and read bar charts, histograms, scatter diagrams and cumulative frequency diagrams; calculate the mean, median and mode
- 34** Calculate the probability of a single event, and simple combined events

10.1 Data display

Bar chart

The length of each bar represents the quantity in question. The width of each bar has no significance. In the bar chart below, the number of the cars of each colour in a car park is shown. The bars can be joined together or separated.

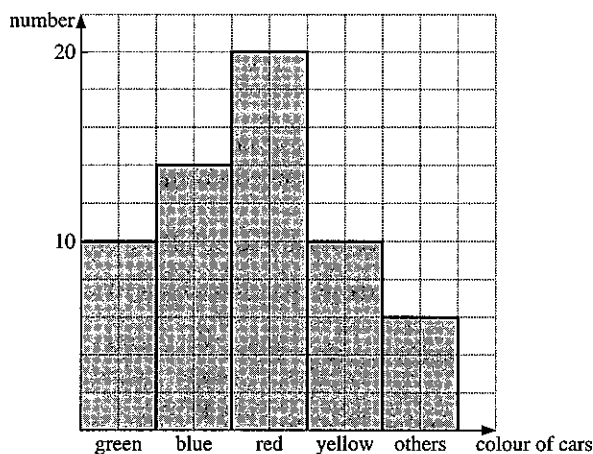

Example

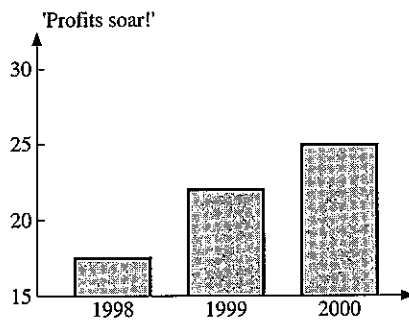
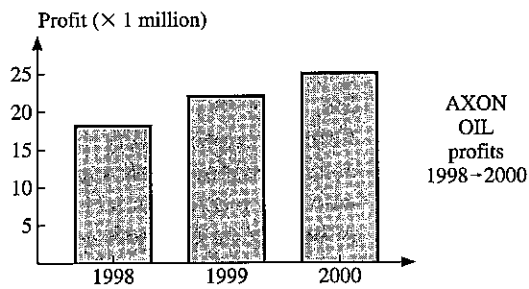

The bar charts show the profits of 'AXON OIL' over a 3-year period. The second graph has been drawn to give the impression that the profits have increased dramatically over the last three years. How has this been done?

Pie chart

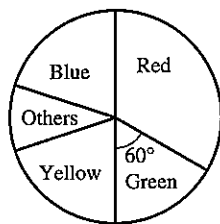

The information is displayed using sectors of a circle. This pie chart shows the same information as the bar chart on the previous page.

The angles of the sectors are calculated as follows:

$$\text{Total number of cars} = 10 + 14 + 20 + 10 + 6 = 60$$

$$\text{Angle representing green cars} = \frac{10}{60} \times 360^\circ = 60^\circ$$

$$\text{Angle representing blue cars} = \frac{14}{60} \times 360^\circ, \text{ etc.}$$

Exercise 1

1. The bar chart shows the number of children playing various games on a given day.

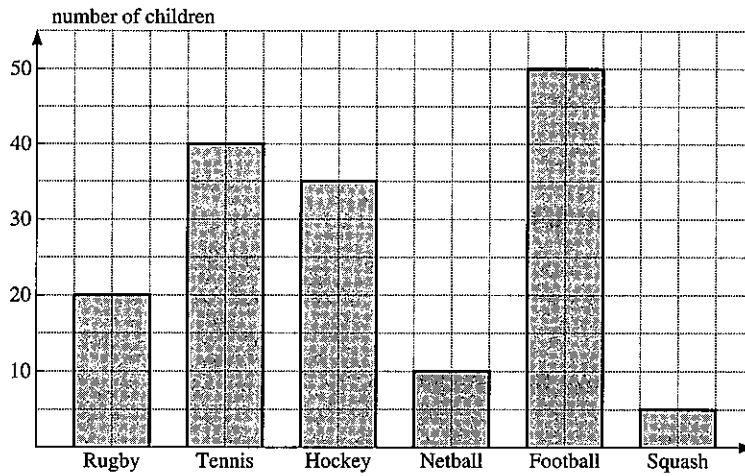

- (a) Which game had the least number of players?
 (b) What was the total number of children playing all the games?
 (c) How many more footballers were there than tennis players?
2. The table shows the number of cars of different makes in a car park. Illustrate this data on a bar chart.

Make	Fiat	Renault	Vauxhall	Rolls Royce	Ford	Datsun
Number	14	23	37	5	42	18

3. The pie chart illustrates the values of various goods sold by a certain shop. If the total value of the sales was \$24 000, find the sales value of:
- (a) toys
 (b) grass seed
 (c) records
 (d) food.

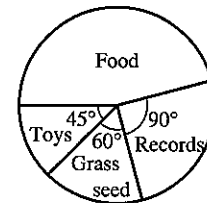

4. The table shows the colours of a random selection of 'Smarties'. Calculate the angles on a pie chart corresponding to each colour.

colour	red	green	blue	yellow	pink
number	5	7	11	4	9

5. A quantity of scrambled eggs is made using the following recipe:

ingredient	eggs	milk	butter	cheese	salt/pepper
mass	450 g	20 g	39 g	90 g	1 g

Calculate the angles on a pie chart corresponding to each ingredient.

6. Calculate the angles on a pie chart corresponding to quantities A, B, C, D and E given in the tables.

(a)	quantity	A	B	C	D	E
	number	3	5	3	7	0

(b)	quantity	A	B	C	D	E
	mass	10 g	15 g	34 g	8 g	5 g

(c)	quantity	A	B	C	D	E
	length	7	11	9	14	11

7. A firm making artificial sand sold its products in four countries:
 5% were sold in Spain
 15% were sold in France
 15% were sold in Germany
 65% were sold in U.K.

What would be the angles on a pie chart drawn to represent this information?

8. The weights of A, B, C are in the ratio 2 : 3 : 4. Calculate the angles representing A, B and C on a pie-chart.

9. The cooking times for meals L, M and N are in the ratio 3 : 7 : x . On a pie-chart, the angle corresponding to L is 60° . Find x .

10. The results of an opinion poll of 2000 people are represented on a pie chart. The angle corresponding to 'don't know' is 18° . How many people in the sample did not know?

11. The pie chart illustrates the sales of various makes of petrol.

- (a) What percentage of sales does 'Esso' have?
 (b) If 'Jet' accounts for $12\frac{1}{2}\%$ of total sales, calculate the angles x and y .

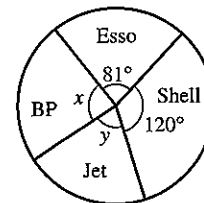

12.	% of total spent
Press	51
Television	40
Posters	
Cinema	
Radio	3
<hr/>	
Total	100

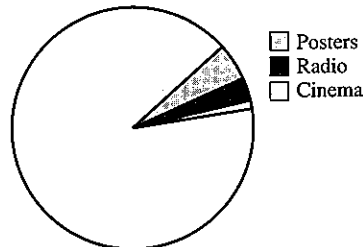

In Spain money was spent on advertisements in 1999 in the press, TV, posters, etc. The incomplete table and pie-chart show the way this was divided between the media.

- (a) Calculate the angle of the sector representing television, and complete the pie-chart.
 (b) The angle of the sector representing posters is 18° . Calculate the percentage spent on posters, and hence complete the table.

13. The diagram illustrates the production of apples in two countries.

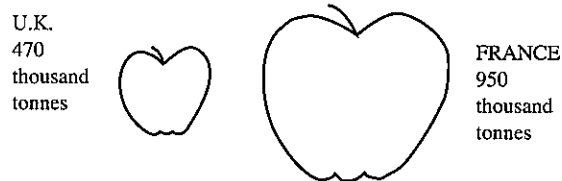

In what way could the pictorial display be regarded as misleading?

14. The graph shows the performance of a company in the year in which a new manager was appointed. In what way is the graph misleading?

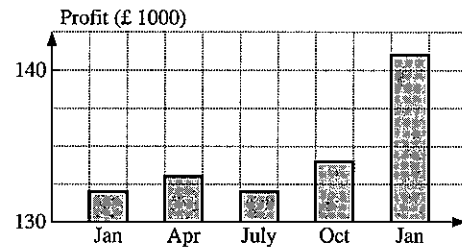

Histograms

In a histogram, the frequency of the data is shown by the *area* of each bar. Histograms resemble bar charts but are not to be confused with them: in bar charts the frequency is shown by the height of each bar. Histograms often have bars of varying widths. Because the area of the bar represents frequency, the height must be adjusted to correspond with the width of the bar. The vertical axis is not labelled frequency but frequency density.

$$\text{frequency density} = \frac{\text{frequency}}{\text{class width}}$$

Histograms can be used to represent both discrete data and continuous data, but their main purpose is for use with continuous data.

Example

Draw a histogram from the table shown for the distribution of ages of passengers travelling on a flight to New York.

Note that the data has been collected into class intervals of different widths.

ages	frequency
$0 \leq x < 20$	28
$20 \leq x < 40$	36
$40 \leq x < 50$	20
$50 \leq x < 70$	30
$70 \leq x < 100$	18



To draw the histogram, the heights of the bars must be adjusted by calculating frequency density.

ages	frequency	frequency density (f.d.)
$0 \leq x < 20$	28	$28 \div 20 = 1.4$
$20 \leq x < 40$	36	$36 \div 20 = 1.8$
$40 \leq x < 50$	20	$20 \div 10 = 2$
$50 \leq x < 70$	30	$30 \div 20 = 1.5$
$70 \leq x < 100$	18	$18 \div 30 = 0.6$

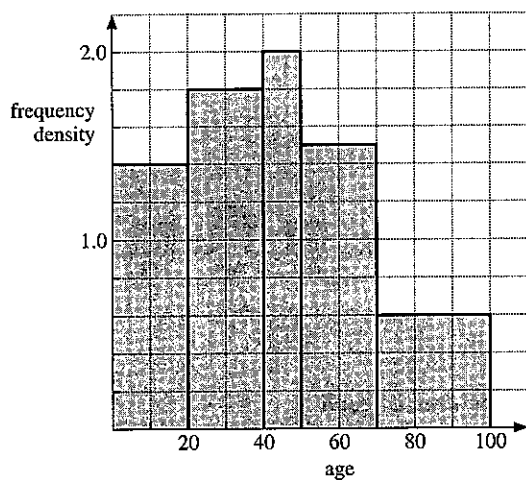

Exercise 2

1. The lengths of 20 copper nails were measured. The results are shown in the frequency table.

length l (in mm)	frequency	frequency density (f.d.)
$0 \leq L < 20$	5	$5 \div 20 = 0.25$
$20 \leq L < 25$	5	
$25 \leq L < 30$	7	
$30 \leq L < 40$	3	

Calculate the frequency densities and draw the histogram as started below.

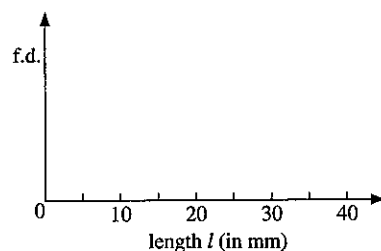

2. The volumes of 55 containers were measured and the results presented in a frequency table as shown in the table.

volume (mm^3)	frequency
$0 \leq V < 5$	5
$5 \leq V < 10$	3
$10 \leq V < 20$	12
$20 \leq V < 30$	17
$30 \leq V < 40$	13
$40 \leq V < 60$	5

Calculate the frequency densities and draw the histogram.

3. Thirty students in a class are weighed on the first day of term. Draw a histogram to represent this data.

weight (kg)	frequency
30–40	5
40–45	7
45–50	10
50–55	5
55–70	3

Note that the weights do not start a zero. This can be shown on the graph as follows:

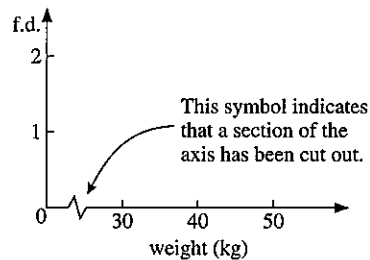

4. The ages of 120 people passing through a turnstyle were recorded and are shown in the frequency table.

age (yrs)	frequency
-10	18
-15	46
-20	35
-30	13
-40	8

The notation -10 means ' $0 < \text{age} \leq 10$ ' and similarly -15 means ' $10 < \text{age} \leq 15$ '. The class boundaries are 0, 10, 15, 20, 30, 40. Draw the histogram for the data.

5. Another common notation is used here for the masses of plums picked in an orchard, shown in the table below.

mass (g)	20–	30–	40–	60–	80–
frequency	11	18	7	5	0

The notation 20– means $20 \text{ g} \leq \text{mass} < 30 \text{ g}$.

Draw a histogram with class boundaries at 20, 30, 40, 60, 80.

6. The heights of 50 Olympic athletes were measured as shown in the table.

height (cm)	170–174	175–179	180–184	185–194
frequency	8	17	14	11

These values were rounded off to the nearest cm. For example, an athlete whose height h is 181 cm could be entered anywhere in the class $180.5 \text{ cm} \leq h < 181.5 \text{ cm}$. So the table is as follows:

height	169.5–174.5	174.5–179.5	179.5–184.5	184.5–194.5
frequency	8	17	14	11

Draw a histogram with class boundaries at 169.5, 174.5, 179.5, ...

7. The number of people travelling in 33 vehicles one day was as shown in the table below.

number of people	1	2	3	4	5–6	7–10
frequency	8	11	6	4	2	2

In this case, the data is discrete. To represent this information on a histogram, draw the column for the value 2, for example, from 1.5 to 2.5, and that for the values 5–6 from 4.5 to 6.5 as shown below.

number of people	frequency	interval on histogram	width of interval	frequency density
1	8	0.5–1.5	1	8
2	11	1.5–2.5		
3	6			
4	4			
5–6	2	4.5–6.5	2	1
7–10	2			

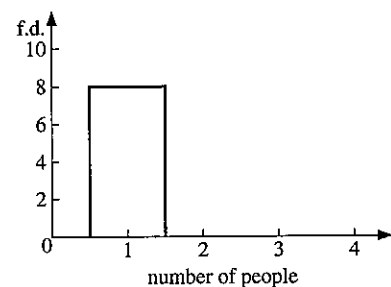

Copy and complete the above table and the histogram which has been started on the right.

10.2 Mean, median and mode

- (a) The *mean* of a series of numbers is obtained by adding the numbers and dividing the result by the number of numbers.
- (b) The *median* of a series of numbers is obtained by arranging the numbers in ascending order and then choosing the number in the 'middle'. If there are *two* 'middle' numbers the median is the average (mean) of these two numbers.
- (c) The *mode* of a series of numbers is simply the number which occurs most often.

Example

Find the mean, median and mode of the following numbers:

5, 4, 10, 3, 3, 4, 7, 4, 6, 5.

$$(a) \text{ Mean} = \frac{(5 + 4 + 10 + 3 + 3 + 4 + 7 + 4 + 6 + 5)}{10} = \frac{51}{10} = 5.1$$

- (b) Median: arranging numbers in order of size
3, 3, 4, 4, 4, 5, 5, 6, 7, 10

↑
The median is the 'average' of 4 and 5

∴ median = 4.5

- (c) Mode = 4 (there are more 4's than any other number).

Frequency tables

A frequency table shows a number x such as a mark or a score, against the frequency f or number of times that x occurs.

The next example shows how these symbols are used in calculating the mean, the median and the mode.

The symbol Σ (or sigma) means 'the sum of'.

Example

The marks obtained by 100 students in a test were as follows:

mark (x)	0	1	2	3	4
frequency (f)	4	19	25	29	23

Find:

- (a) the mean mark (b) the median mark (c) the modal mark

$$(a) \text{ Mean} = \frac{\Sigma xf}{\Sigma f}$$

where Σxf means 'the sum of the products'

i.e. $\Sigma(\text{number} \times \text{frequency})$

and Σf means 'the sum of the frequencies'

$$\begin{aligned}\text{Mean} &= \frac{(0 \times 4) + (1 \times 19) + (2 \times 25) + (3 \times 29) + (4 \times 23)}{100} \\ &= \frac{248}{100} = 2.48\end{aligned}$$

- (b) The median mark is the number between the 50th and 51st numbers. By inspection, both the 50th and 51st numbers are 3.

\therefore Median = 3 marks

- (c) The modal mark = 3

Exercise 3

- Find the mean, median and mode of the following sets of numbers:
 - 3, 12, 4, 6, 8, 5, 4
 - 7, 21, 2, 17, 3, 13, 7, 4, 9, 7, 9
 - 12, 1, 10, 1, 9, 3, 4, 9, 7, 9
 - 8, 0, 3, 3, 1, 7, 4, 1, 4, 4
- Find the mean, median and mode of the following sets of numbers:
 - 3, 3, 5, 7, 8, 8, 8, 9, 11, 12, 12
 - 7, 3, 4, 10, 1, 2, 1, 3, 4, 11, 10, 4
 - 3, 4, 0, 4, -2, -5, 1, 7, 10, 5
 - $1, \frac{1}{2}, \frac{1}{2}, \frac{3}{4}, \frac{1}{4}, 2, \frac{1}{2}, \frac{1}{4}, \frac{3}{4}$
- The mean weight of five men is 76 kg. The weights of four of the men are 72 kg, 74 kg, 75 kg and 81 kg. What is the weight of the fifth man?
- The mean length of 6 rods is 44.2 cm. The mean length of 5 of them is 46 cm. How long is the sixth rod?
- The mean of 3, 7, 8, 10 and x is 6. Find x .
 - The mean of 3, 3, 7, 8, 10, x and x is 7. Find x .
- The mean height of 12 men is 1.70 m, and the mean height of 8 women is 1.60 m. Find:
 - the total height of the 12 men,
 - the total height of the 8 women,
 - the mean height of the 20 men and women.
- The total weight of 6 rugby players is 540 kg and the mean weight of 14 ballet dancers is 40 kg. Find the mean weight of the group of 20 rugby players and ballet dancers.
- The mean weight of 8 boys is 55 kg and the mean weight of a group of girls is 52 kg. The mean weight of all the children is 53.2 kg. How many girls are there?
- For the set of numbers below, find the mean and the median.

1, 3, 3, 3, 4, 6, 99.

Which average best describes the set of numbers?

10. In a history test, Andrew got 62%. For the whole class, the mean mark was 64% and the median mark was 59%. Which 'average' tells Andrew whether he is in the 'top' half or the 'bottom' half of the class?

11. The mean age of three people is 22 and their median age is 20. The range of their ages is 16. How old is each person?

12. A group of 50 people were asked how many books they had read in the previous year; the results are shown in the frequency table below. Calculate the mean number of books read per person.

Number of books	0	1	2	3	4	5	6	7	8
Frequency	5	5	6	9	11	7	4	2	1

13. A number of people were asked how many coins they had in their pockets; the results are shown below. Calculate the mean number of coins per person.

Number of coins	0	1	2	3	4	5	6	7
Frequency	3	6	4	7	5	8	5	2

14. The following tables give the distribution of marks obtained by different classes in various tests. For each table, find the mean, median and mode.

(a)

Mark	0	1	2	3	4	5	6
Frequency	3	5	8	9	5	7	3

(b)

Mark	15	16	17	18	19	20
Frequency	1	3	7	1	5	3

(c)

Mark	0	1	2	3	4	5	6
Frequency	10	11	8	15	25	20	11

15. One hundred golfers play a certain hole and their scores are summarised below.

Score	2	3	4	5	6	7	8
Number of players	2	7	24	31	18	11	7

Find:

- (a) the mean score (b) the median score.

16. The number of goals scored in a series of football matches was as follows:

Number of goals	1	2	3
Number of matches	8	8	x

- (a) If the mean number of goals is 2.04, find x .
 (b) If the modal number of goals is 3, find the smallest possible value of x .
 (c) If the median number of goals is 2, find the largest possible value of x .
17. In a survey of the number of occupants in a number of cars, the following data resulted.

Number of occupants	1	2	3	4
Number of cars	7	11	7	x

- (a) If the mean number of occupants is $2\frac{1}{3}$, find x .
 (b) If the mode is 2, find the largest possible value of x .
 (c) If the median is 2, find the largest possible value of x .
18. The numbers 3, 5, 7, 8 and N are arranged in ascending order. If the mean of the numbers is equal to the median, find N .
19. The mean of 5 numbers is 11. The numbers are in the ratio 1:2:3:4:5. Find the smallest number.
20. The mean of a set of 7 numbers is 3.6 and the mean of a different set of 18 numbers is 5.1. Calculate the mean of the 25 numbers.
21. The results of 24 students in a test are given in the table.

mark	frequency
85–99	4
70–84	7
55–69	8
40–54	5

For grouped data such as this, each group can be represented *approximately* by its mid-point. For example, for the 85–99 interval, we say there are 4 marks of 92 (the mid-point).

- (a) Find the mid-point of each group of marks and calculate an estimate of the mean mark.
 (b) Explain why your answer is an estimate.

Scatter graphs

Sometimes it is important to discover if there is a connection or relationship between two sets of data.

Examples:

- Are more ice creams sold when the weather is hot?
- Do tall people have higher pulse rates?
- Are people who are good at maths also good at science?
- Does watching TV improve examination results?

If there is a relationship, it will be easy to spot if your data is plotted on a scatter diagram – that is a graph in which one set of data is plotted on the horizontal axis and the other on the vertical axis.

Here is a scatter graph showing the price of pears and the quantity sold.

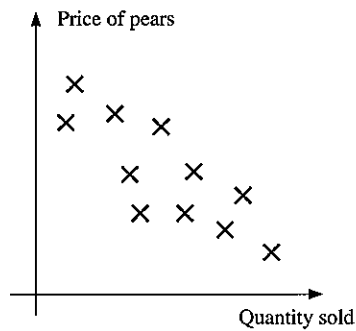

We can see a *connection* – when the price was high the sales were low and when the price went down the sales increased.

This scatter graph shows the sales of a newspaper and the temperature. We can see there is *no connection* between the two variables.

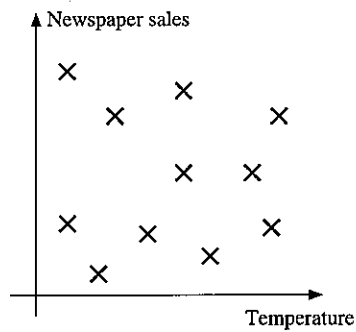

Correlation

The word correlation describes how things *co-relate*. There is correlation between two sets of data if there is a connection or relationship.

The correlation between two sets of data can be positive or negative and it can be strong or weak as indicated by the scatter graphs below.

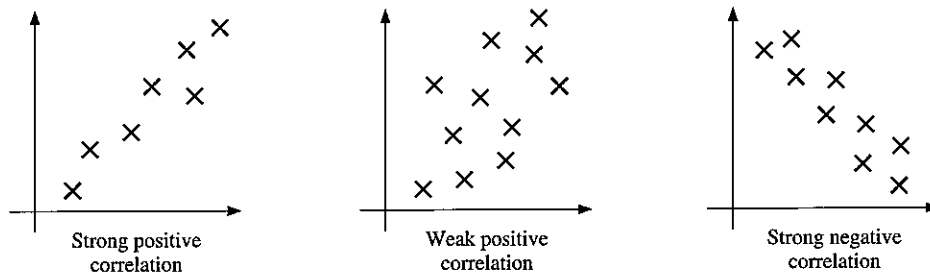

When the correlation is positive the points are around a line which slopes upwards to the right. When the correlation is negative the 'line' slopes downwards to the right.

When the correlation is strong the points are bunched close to a line through their midst. When the correlation is weak the points are more scattered.

It is important to realise that often there is *no* correlation between two sets of data.

If, for example, we take a group of students and plot their maths test results against their time to run 800 m, the graph might look like the one on the right. A common mistake in this topic is to 'see' a correlation on a scatter graph where none exists.

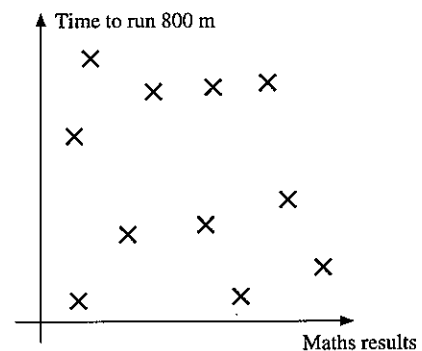

There is also *no* correlation in these two scatter graphs.

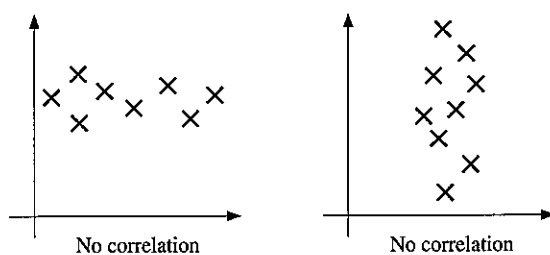

Line of best fit

When a scatter graph shows either positive or negative correlation, a *line of best fit* can be drawn. The sums of the distances to points on either side of the line are equal and there should be an equal number of points on each side of the line. The line is easier to draw when a transparent ruler is used.

Here are the marks obtained in two tests by 9 students.

Student	A	B	C	D	E	F	G	H	I
Maths mark	28	22	9	40	37	35	30	23	?
Physics mark	48	45	34	57	50	55	53	45	52

A line of best fit can be drawn as there is strong positive correlation between the two sets of marks.

The line of best fit can be used to estimate the maths result of student 1, who missed the maths test but scored 52 in the physics test.

We can *estimate that student 1 would have scored about 33 in the maths test*. It is not possible to be *very accurate* using scatter graphs. It is reasonable to state that student 1 'might have scored between 30 and 36' in the maths test.

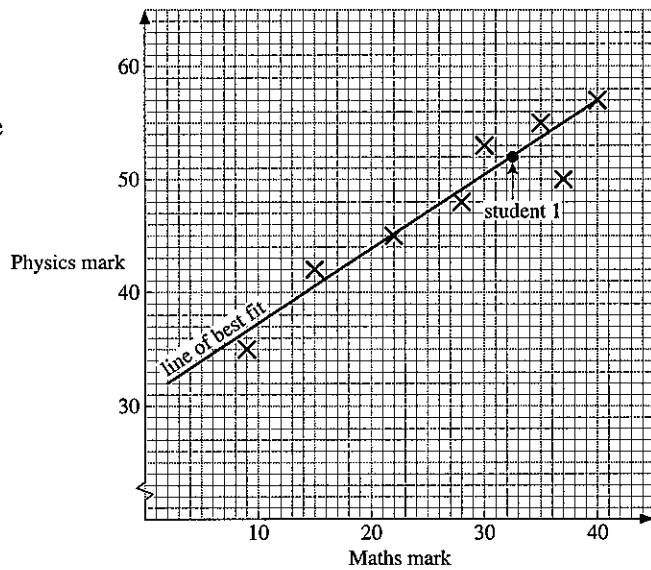

Here is a scatter graph in which the heights of boys of different ages is recorded. A line of best fit is drawn.

- (a) We can estimate that the height of an 8-year-old boy might be about 123 cm [say between 120 and 126 cm].
- (b) We can only predict a height within the range of values plotted. We could not extend the line of best and use it to predict the height of a 30 year old! Why not?

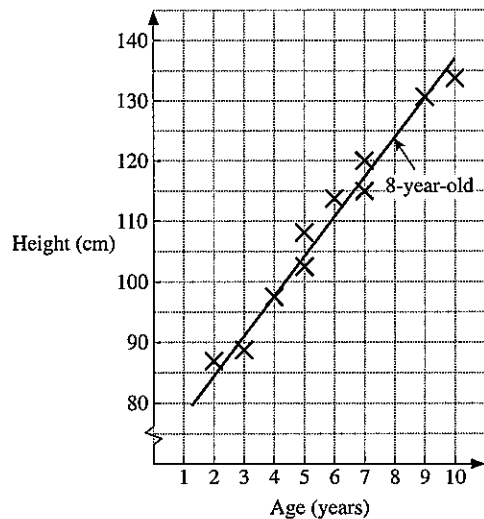

Exercise 4

1. Make the following measurements for everyone in your class:
- | | |
|--------------------|----------------|
| height | (nearest cm) |
| arm span | (nearest cm) |
| head circumference | (nearest cm) |
| hand span | (nearest cm) |
| pulse rate | (beats/minute) |

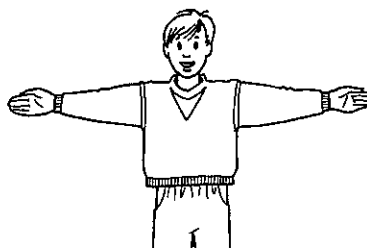

For greater consistency of measuring, one person (or perhaps two people) should do all the measurements of one kind (except on themselves!).

Enter all the measurements in a table, either on the board or on a sheet of paper.

Name	Height	Armspan	Head
Roger	161	165	56
Liz	150	148	49
Gill			

- (a) Draw the scatter graphs shown below:

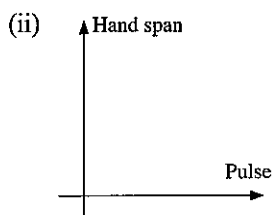
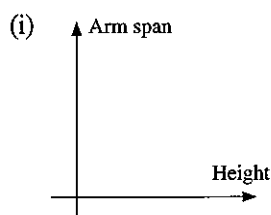

- (b) Describe the correlation, if any, in the scatter graphs you drew in part (a).
- (c) (i) Draw a scatter graph of two measurements where you think there might be positive correlation.
(ii) Was there indeed a positive correlation?

2. Plot the points given on a scatter graph, with s across the page and p up the page. Draw axes with values from 0 to 20.

Describe the correlation, if any, between the values of s and p . [i.e. 'strong negative', 'weak positive' etc.]

(a)

s	7	16	4	12	18	6	20	4	10	13
p	8	15	6	12	17	9	18	7	10	14

(b)

s	3	8	12	15	16	5	6	17	9
p	4	2	10	17	5	10	17	11	15

(c)

s	11	1	16	7	2	19	8	4	13	18
p	5	12	7	14	17	1	11	8	11	5

In Questions 3, 4 and 5 plot the points given on a scatter graph, with s across the page and p up the page.

draw axes with the values from 0 to 20.

If possible draw a line of best fit on the graph.

Where possible estimate the value of p on the line of best fit where $s = 10$.

3.

s	2	14	14	4	12	18	12	6
p	5	15	16	6	12	18	13	7

4.

s	2	15	17	3	20	3	6
p	13	7	5	12	4	13	11

5.

s	4	10	15	18	19	4	19	5
p	19	16	11	19	15	3	1	9

6. The following data gives the marks of 11 students in a French test and in a German test.

French	15	36	36	22	23	27	43	22	43	40	26
German	6	28	35	18	28	28	37	9	41	45	17

- (a) Plot this data on a scatter graph, with French marks on the horizontal axis.
 (b) Draw the line of best fit.
 (c) Estimate the German mark of a student who got 30 in French.
 (d) Estimate the French mark of a student who got 45 in German.
7. The data below gives the petrol consumption figures of cars, with the same size engine, when driven at different speeds.

Speed (m.p.h.)	30	62	40	80	70	55	75
Petrol consumption (m.p.g.)	38	25	35	20	26	34	22

- (a) Plot a scatter graph and draw a line of best fit.
 (b) Estimate the petrol consumption of a car travelling at 45 m.p.h.
 (c) Estimate the speed of a car whose petrol consumption is 27 m.p.g.

10.3 Cumulative frequency

Cumulative frequency is the total frequency up to a given point.

A cumulative frequency curve (or ogive) shows the *median* at the 50th percentile of the cumulative frequency.

The value at the 25th percentile is known as the *lower quartile*, and that at the 75th percentile as the *upper quartile*.

A measure of the spread or dispersion of the data is given by the *interquartile range* where

$$\text{inter-quartile range} = \text{upper quartile} - \text{lower quartile}$$

Example

The marks obtained by 80 students in an examination are shown below.

mark	frequency	cumulative frequency	marks represented by cumulative frequency
1–10	3	3	≤ 10
11–20	5	8	≤ 20
21–30	5	13	≤ 30
31–40	9	22	≤ 40
41–50	11	33	≤ 50
51–60	15	48	≤ 60
61–70	14	62	≤ 70
71–80	8	70	≤ 80
81–90	6	76	≤ 90
91–100	4	80	≤ 100

The table also shows the cumulative frequency.

Plot a cumulative frequency curve and hence estimate:

- the median
- the inter-quartile range.

The points on the graph are plotted at the upper limit of each group of marks.

From the cumulative frequency curve

$$\begin{aligned} \text{median} &= 55 \text{ marks} \\ \text{lower quartile} &= 37.5 \text{ marks} \\ \text{upper quartile} &= 68 \text{ marks} \\ \therefore \text{inter-quartile range} &= 68 - 37.5 \\ &= 30.5 \text{ marks.} \end{aligned}$$

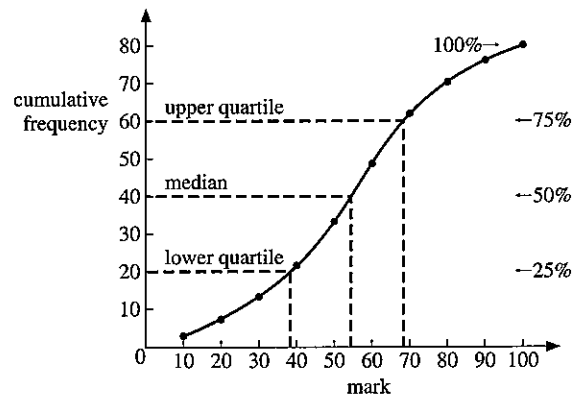

Exercise 5

1. Figure 1 shows the cumulative frequency curve for the marks of 60 students in an examination.

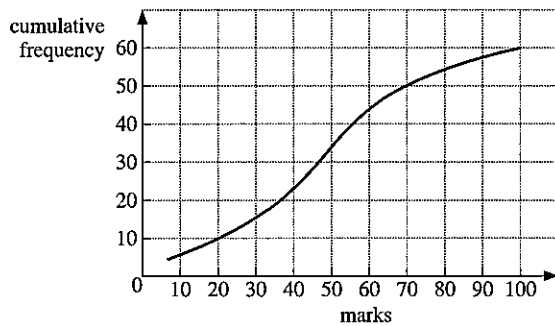

Figure 1

From the graph, estimate:

- the median mark,
 - the mark at the lower quartile and at the upper quartile,
 - the inter-quartile range,
 - the pass mark if two-thirds of the students passed,
 - the number of students achieving less than 40 marks.
2. Figure 2 shows the cumulative frequency curve for the marks of 140 students in an examination.

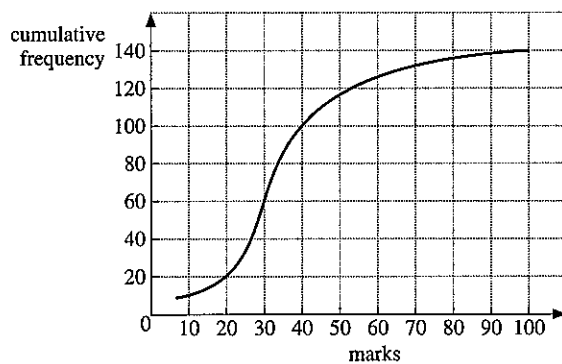

Figure 2

From the graph, estimate:

- the median mark,
- the mark at the lower quartile and at the upper quartile,
- the inter-quartile range,
- the pass mark if three-fifths of the students passed,
- the number of students achieving more than 0 marks.

In questions 3 to 6, draw a cumulative frequency curve, and find:

(a) the median, (b) the interquartile range.

3. mass (kg)	frequency
1-5	4
6-10	7
11-15	11
16-20	18
21-25	22
26-30	10
31-35	5
36-40	3

4. length (cm)	frequency
41-50	6
51-60	8
61-70	14
71-80	21
81-90	26
91-100	14
101-110	7
111-120	4

5. time (seconds)	frequency
36-45	3
46-55	7
56-65	10
66-75	18
76-85	12
86-95	6
96-105	4

6. number of marks	frequency
1-10	0
11-20	2
21-30	4
31-40	10
41-50	17
51-60	11
61-70	3
71-80	3

7. In an experiment, 50 people were asked to guess the weight of a bunch of daffodils in grams. The guesses were as follows:

47 39 21 30 42 35 44 36 19 52
 23 32 66 29 5 40 33 11 44 22
 27 58 38 37 48 63 23 40 53 24
 47 22 44 33 13 59 33 49 57 30
 17 45 38 33 25 40 51 56 28 64

Construct a frequency table using intervals 0-9, 10-19, 20-29, etc. Hence draw a cumulative frequency curve and estimate:

- the median weight,
- the inter-quartile range,
- the number of people who guessed a weight within 10 grams of the median.

8. In a competition, 30 children had to pick up as many paper clips as possible in one minute using a pair of tweezers. The results were as follows:

3 17 8 11 26 23 18 28 33 38
 12 38 22 50 5 35 39 30 31 43
 27 34 9 25 39 14 27 16 33 49

Construct a frequency table using intervals 1–10, 11–20, etc. and hence draw a cumulative frequency curve.

- From the curve, estimate the median number of clips picked up.
 - From the frequency table, estimate the mean of the distribution using the mid-interval values 5.5, 15.5, etc.
 - Calculate the exact value of the mean using the original data.
 - Why is it possible only to estimate the mean in part (b)?
9. The children in two schools took the same test in mathematics and their results are shown.

St Mary's School	Birchwood School
median mark = 52%	median mark = 51.8%
IQR = 7.2	IQR = 11.2

Note: IQR is shorthand for inter-quartile range.

What can you say about these two sets of results?

10. As part of a health improvement programme, people from one town and from one village in Gambia were measured. Here are the results.

People in town	People in village
median height = 171 cm	median height = 163 cm
IQR = 8.4	IQR = 3.7

What can you say about these two sets of results?

10.4 Simple probability

Probability theory is not the sole concern of people interested in betting, although it is true to say that a 'lucky' poker player is likely to be a player with a sound understanding of probability. All major airlines regularly overbook aircraft because they can usually predict with accuracy the probability that a certain number of passengers will fail to arrive for the flight.

Suppose a 'trial' can have n equally likely results and suppose that a 'success' can occur in s ways (from the n). Then the probability of a

$$\text{'success'} = \frac{s}{n}.$$

- If an event **cannot** happen the probability of it occurring is 0.
- If an event is **certain** to happen the probability of it occurring is 1.
- All probabilities lie between 0 and 1.

You write probabilities using fractions or decimals.

Example 1

The numbers 1 to 20 are each written on a card.
 The 20 cards are mixed together.
 One card is chosen at random from the pack.
 Find the probability that the number on the card is:

- (a) even (b) a factor of 24 (c) prime.

We will use ' $p(x)$ ' to mean 'the probability of x '.

$$\begin{array}{lll}
 \text{(a) } p(\text{even}) = \frac{10}{20} & \text{(b) } p(\text{factor of 24}) & \text{(c) } p(\text{prime}) \\
 = \frac{1}{2} & = p(1, 2, 3, 4, 6, 8, 12) & = p(2, 3, 5, 7, 11, 13, 17, 19) \\
 & = \frac{7}{20} & = \frac{8}{20} = \frac{2}{5}
 \end{array}$$

In each case, we have counted the number of ways in which a 'success' can occur and divided by the number of possible results of a 'trial'.

Example 2

A black die and a white die are thrown at the same time. Display all the possible outcomes. Find the probability of obtaining:

- (a) a total of 5,
 (b) a total of 11,
 (c) a 'two' on the black die and a 'six' on the white die.

It is convenient to display all the possible outcomes on a grid.

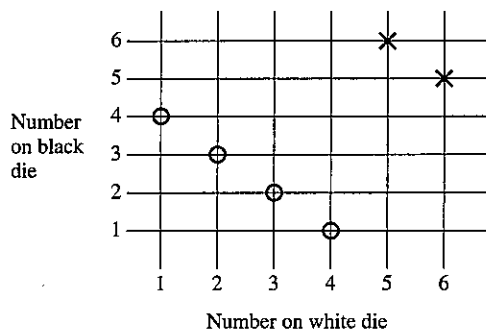

There are 36 possible outcomes, shown where the lines cross.

- (a) There are four ways of obtaining a total of 5 on the two dice. They are shown circled on the diagram.

$$\therefore \text{Probability of obtaining a total of 5} = \frac{4}{36}$$

- (b) There are two ways of obtaining a total of 11. They are shown with a cross on the diagram.

$$\therefore p(\text{total of 11}) = \frac{2}{36} = \frac{1}{18}$$

- (c) There is only one way of obtaining a 'two' on the black die and a 'six' on the white die.

$$\therefore p(2 \text{ on black and } 6 \text{ on white}) = \frac{1}{36}$$

Exercise 6

In this exercise, all dice are normal cubic dice with faces numbered 1 to 6.

- A fair die is thrown once. Find the probability of obtaining:
 - a six,
 - an even number,
 - a number greater than 3,
 - a three or a five.
- The two sides of a coin are known as 'head' and 'tail'. A 10c and a 5c coin are tossed at the same time. List all the possible outcomes. Find the probability of obtaining:
 - two heads,
 - a head and a tail.
- A bag contains 6 red balls and 4 green balls.
 - Find the probability of selecting at random:
 - a red ball
 - a green ball.
 - One red ball is removed from the bag. Find the new probability of selecting at random
 - a red ball
 - a green ball.
- One letter is selected at random from the word 'UNNECESSARY'. Find the probability of selecting:
 - an R
 - an E
 - an O
 - a C
- Three coins are tossed at the same time. List all the possible outcomes. Find the probability of obtaining:
 - three heads,
 - two heads and one tail,
 - no heads,
 - at least one head.
- A bag contains 10 red balls, 5 blue balls and 7 green balls. Find the probability of selecting at random:
 - a red ball,
 - a green ball,
 - a blue *or* a red ball,
 - a red *or* a green ball.
- Cards with the numbers 2 to 101 are placed in a hat. Find the probability of selecting:
 - an even number,
 - a number less than 14,
 - a square number,
 - a prime number less than 20.

8. A red die and a blue die are thrown at the same time. List all the possible outcomes in a systematic way. Find the probability of obtaining:
- a total of 10,
 - a total of 12,
 - a total less than 6,
 - the same number on both dice,
 - a total more than 9.
- What is the most likely total?
9. A die is thrown; when the result has been recorded, the die is thrown a second time. Display all the possible outcomes of the two throws. Find the probability of obtaining:
- a total of 4 from the two throws,
 - a total of 8 from the two throws,
 - a total between 5 and 9 inclusive from the two throws,
 - a number on the second throw which is double the number on the first throw,
 - a number on the second throw which is four times the number on the first throw.
10. Find the probability of the following:
- throwing a number less than 8 on a single die,
 - obtaining the same number of heads and tails when five coins are tossed,
 - selecting a square number from the set $A = \{4, 9, 16, 25, 36, 49\}$,
 - selecting a prime number from the set A.
11. Four coins are tossed at the same time. List all the possible outcomes in a systematic way. Find the probability of obtaining:
- two heads and two tails,
 - four tails,
 - at least one tail,
 - three heads and one tail.
12. Louise buys five raffle tickets out of 1000 sold. She does not win first prize. What is the probability that she wins second prize?
13. Tickets numbered 1 to 1000 were sold in a raffle for which there was one prize. Mr Kahn bought all the tickets containing at least one '3' because '3' was his lucky number. What was the probability of Mr Kahn winning?
14. One ball is selected at random from a bag containing 12 balls of which x are white.
- What is the probability of selecting a white ball?
When a further 6 white balls are added the probability of selecting a white ball is doubled.
 - Find x .

Remember
'head' and 'tail' are the two sides of a coin

15. Two dice and two coins are thrown at the same time. Find the probability of obtaining:
- two heads and a total of 12 on the dice,
 - a head, a tail and a total of 9 on the dice,
 - two tails and a total of 3 on the dice.
- What is the most likely outcome?
16. A red, a blue and a green die are all thrown at the same time. Display all the possible outcomes in a suitable way. Find the probability of obtaining:
- a total of 18 on the three dice,
 - a total of 4 on the three dice,
 - a total of 10 on the three dice,
 - a total of 15 on the three dice,
 - a total of 7 on the three dice,
 - the same number on each die.

10.5 Exclusive and independent events

Two events are *exclusive* if they cannot occur at the same time:
e.g. Selecting an 'even number' or selecting a 'one' from a set of numbers.

The 'OR' rule:

For exclusive events A and B

$$p(A \text{ or } B) = p(A) + p(B)$$

Two events are *independent* if the occurrence of one event is unaffected by the occurrence of the other.

e.g. Obtaining a 'head' on one coin, and a 'tail' on another coin when the coins are tossed at the same time.

The 'AND' rule:

$$p(A \text{ and } B) = p(A) \times p(B)$$

where $p(A)$ = probability of A occurring etc. This is the multiplication law.

Example 1

One ball is selected at random from a bag containing 5 red balls, 2 yellow balls and 4 white balls. Find the probability of selecting a red ball or a white ball.

The two events are exclusive.

$$\begin{aligned} p(\text{red ball or white ball}) &= p(\text{red}) + p(\text{white}) \\ &= \frac{5}{11} + \frac{4}{11} \\ &= \frac{9}{11} \end{aligned}$$



Example 2

A fair coin is tossed and a fair die is rolled. Find the probability of obtaining a 'head' and a 'six'.

The two events are independent

$$\begin{aligned} p(\text{head and six}) &= p(\text{head}) \times p(\text{six}) \\ &= \frac{1}{2} \times \frac{1}{6} \\ &= \frac{1}{12} \end{aligned}$$

Exercise 7

- A coin is tossed and a die is thrown. Write down the probability of obtaining:
 - a 'head' on the coin,
 - an odd number on the die,
 - a 'head' on the coin and an odd number on the die.
- A ball is selected at random from a bag containing 3 red balls, 4 black balls and 5 green balls. The first ball is replaced and a second is selected. Find the probability of obtaining:
 - two red balls,
 - two green balls.
- The letters of the word 'INDEPENDENT' are written on individual cards and the cards are put into a box. A card is selected and then replaced and then a second card is selected. Find the probability of obtaining:
 - the letter 'P' twice,
 - the letter 'E' twice.
- Three coins are tossed and two dice are thrown at the same time. Find the probability of obtaining:
 - three heads and a total of 12 on the dice,
 - three tails and a total of 9 on the dice.
- When a golfer plays any hole, he will take 3, 4, 5, 6, or 7 strokes with probabilities of $\frac{1}{10}$, $\frac{1}{5}$, $\frac{2}{5}$, $\frac{1}{5}$ and $\frac{1}{10}$ respectively. He never takes more than 7 strokes. Find the probability of the following events:
 - scoring 4 on each of the first three holes,
 - scoring 3, 4 and 5 (in that order) on the first three holes,
 - scoring a total of 28 for the first four holes,
 - scoring a total of 10 for the first three holes,
 - scoring a total of 20 for the first three holes.
- A coin is biased so that it shows 'heads' with a probability of $\frac{2}{3}$. The same coin is tossed three times. Find the probability of obtaining:
 - two tails on the first two tosses,
 - a head, a tail and a head (in that order),
 - two heads and one tail (in any order).

10.6 Tree diagrams

Example 1

A bag contains 5 red balls and 3 green balls. A ball is drawn at random and then replaced. Another ball is drawn. What is the probability that both balls are green?

The branch marked * involves the selection of a green ball twice. The probability of this event is obtained by simply multiplying the fractions on the two branches.

$$\therefore p(\text{two green balls}) = \frac{3}{8} \times \frac{3}{8} = \frac{9}{64}$$

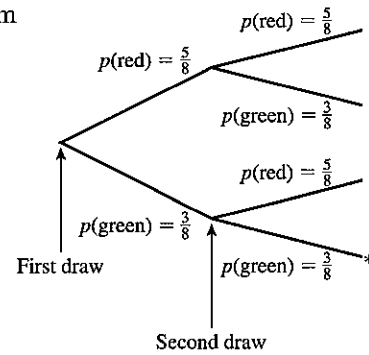

Example 2

A bag contains 5 red balls and 3 green balls. A ball is selected at random and not replaced. A second ball is then selected. Find the probability of selecting:

- (a) two green balls
- (b) one red ball and one green ball.

$$(a) p(\text{two green balls}) = \frac{3}{8} \times \frac{2}{7} = \frac{3}{28}$$

$$(b) p(\text{one red, one green}) = \left(\frac{5}{8} \times \frac{3}{7}\right) + \left(\frac{3}{8} \times \frac{5}{7}\right) = \frac{15}{28}$$

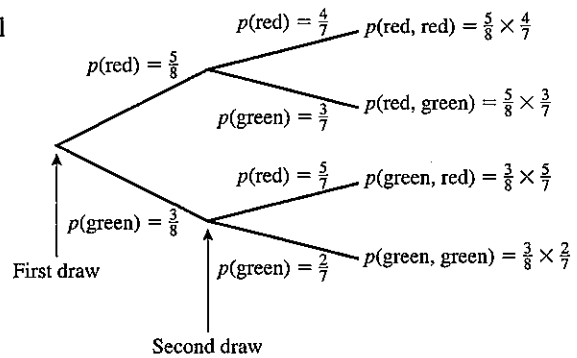

Exercise 8

1. A bag contains 10 discs; 7 are black and 3 white. A disc is selected, and then replaced. A second disc is selected. Copy and complete the tree diagram showing all the probabilities and outcomes.

Find the probability of the following:

- (a) both discs are black,
- (b) both discs are white.

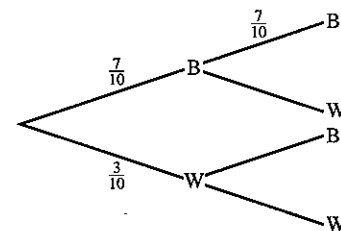

2. A bag contains 5 red balls and 3 green balls. A ball is drawn and then replaced before a ball is drawn again. Draw a tree diagram to show all the possible outcomes. Find the probability that:
- two green balls are drawn,
 - the first ball is red and the second is green.

3. A bag contains 7 green discs and 3 blue discs. A disc is drawn and *not* replaced. A second disc is drawn. Copy and complete the tree diagram. Find the probability that:
- both discs are green,
 - both discs are blue.

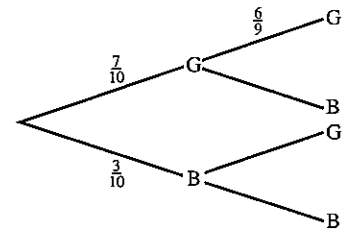

4. A bag contains 5 red balls, 3 blue balls and 2 yellow balls. A ball is drawn and not replaced. A second ball is drawn. Find the probability of drawing:
- two red balls,
 - one blue ball and one yellow ball,
 - two yellow balls,
 - two balls of the same colour.
5. A bag contains 4 red balls, 2 green balls and 3 blue balls. A ball is drawn and not replaced. A second ball is drawn. Find the probability of drawing:
- two blue balls,
 - two red balls,
 - one red ball and one blue ball,
 - one green ball and one red ball.
6. A six-sided die is thrown three times. Draw a tree diagram, showing at each branch the two events: 'six' and 'not six'. What is the probability of throwing a total of:
- three sixes,
 - no sixes,
 - one six,
 - at least one six (use part (b)).
7. A bag contains 6 red marbles and 4 blue marbles. A marble is drawn at random and not replaced. Two further draws are made, again without replacement. Find the probability of drawing:
- three red marbles,
 - three blue marbles,
 - no red marbles,
 - at least one red marble.
8. When a cutting is taken from a geranium the probability that it grows is $\frac{3}{4}$. Three cuttings are taken. What is the probability that:
- all three grow,
 - none of them grow?

9. A die has its six faces marked 0, 1, 1, 1, 6, 6. Two of these dice are thrown together and the total score is recorded. Draw a tree diagram.
- How many different totals are possible?
 - What is the probability of obtaining a total of 7?
10. A coin is biased so that the probability of a 'head' is $\frac{3}{4}$. Find the probability that, when tossed three times, it shows:
- three tails,
 - two heads and one tail,
 - one head and two tails,
 - no tails.
- Write down the sum of the probabilities in (a), (b), (c) and (d).
11. A teacher decides to award exam grades A, B or C by a new method. Out of 20 children, three are to receive A's, five B's and the rest C's. She writes the letters A, B and C on 20 pieces of paper and invites the pupils to draw their exam result, going through the class in alphabetical order. Find the probability that:
- the first three pupils all get grade 'A'.
 - the first three pupils all get grade 'B',
 - the first three pupils all get different grades,
 - the first four pupils all get grade B.
- (Do not cancel down the fractions.)
12. The probability that an amateur golfer actually hits the ball is (regrettably for all concerned) only $\frac{1}{10}$. If four separate attempts are made, find the probability that the ball will be hit:
- four times,
 - at least twice,
 - not at all.
13. A box contains x milk chocolates and y plain chocolates. Two chocolates are selected at random. Find, in terms of x and y , the probability of choosing:
- a milk chocolate on the first choice,
 - two milk chocolates,
 - one of each sort,
 - two plain chocolates.
14. If a hedgehog crosses a certain road before 7.00 a.m., the probability of being run over is $\frac{1}{10}$. After 7.00 a.m., the corresponding probability is $\frac{3}{4}$. The probability of the hedgehog waking up early enough to cross before 7.00 a.m., is $\frac{4}{5}$. What is the probability of the following events:
- the hedgehog waking up too late to reach the road before 7.00 a.m.,
 - the hedgehog waking up early and crossing the road in safety,
 - the hedgehog waking up late and crossing the road in safety,
 - the hedgehog waking up early and being run over,
 - the hedgehog crossing the road in safety.



15. Bag A contains 3 red balls and 3 blue balls.
 Bag B contains 1 red ball and 3 blue balls.
 A ball is taken at random from bag A and placed in bag B. A ball is then chosen from bag B. What is the probability that the ball taken from B is red?

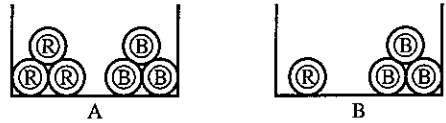

16. On a Monday or a Thursday, Mr Gibson paints a 'masterpiece' with a probability of $\frac{1}{5}$. On any other day, the probability of producing a 'masterpiece' is $\frac{1}{100}$. In common with other great painters, Mr Gibson never knows what day it is. Find the probability that on one day chosen at random, he will in fact paint a masterpiece.
17. Two dice, each with four faces marked 1, 2, 3 and 4, are thrown together.
- What is the most likely total score on the faces pointing downwards?
 - What is the probability of obtaining this score on three successive throws of the two dice?

18. In the Venn diagram, $\mathcal{E} = \{\text{pupils in a class of 15}\}$, $G = \{\text{girls}\}$, $S = \{\text{swimmers}\}$, $F = \{\text{pupils who believe in Father Christmas}\}$. A pupil is chosen at random. Find the probability that the pupil:
- can swim,
 - is a girl swimmer,
 - is a boy swimmer who believes in Father Christmas.
- Two pupils are chosen at random. Find the probability that:
- both are boys,
 - neither can swim,
 - both are girl swimmers who believe in Father Christmas.

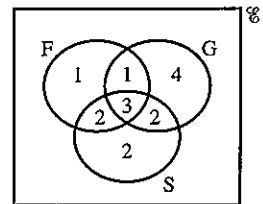

19. A bag contains 3 red, 4 white and 5 green balls. Three balls are selected without replacement. Find the probability that the three balls chosen are:
- all red,
 - all green,
 - one of each colour.
- If the selection of the three balls was carried out 1100 times, how often would you expect to choose:
- three red balls?
 - one of each colour?
20. There are 1000 components in a box of which 10 are known to be defective. Two components are selected at random. What is the probability that:
- both are defective,
 - neither are defective,
 - just one is defective?
- (Do *not* simplify your answers)

21. There are 10 boys and 15 girls in a class. Two children are chosen at random. What is the probability that:
- both are boys,
 - both are girls,
 - one is a boy and one is a girl?
22. There are 500 ball bearings in a box of which 100 are known to be undersize. Three ball bearings are selected at random. What is the probability that:
- all three are undersize, (b) none are undersize?
- Give your answers as decimals correct to three significant figures.
23. There are 9 boys and 15 girls in a class. Three children are chosen at random. What is the probability that:
- all three are boys,
 - all three are girls,
 - one is a boy and two are girls?
- Give your answers as fractions.

Revision exercise 10A

1. A pie chart is drawn with sectors to represent the following percentages:

20%, 45%, 30%, 5%.

What is the angle of the sector which represents 45%?

2. The pie chart shows the numbers of votes for candidates A, B and C in an election.

What percentage of the votes were cast in favour of candidate C?

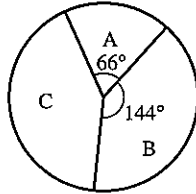

3. A pie chart is drawn showing the expenditure of a football club as follows:

Wages	£41 000
Travel	£9 000
Rates	£6 000
Miscellaneous	£4 000

What is the angle of the sector showing the expenditure on travel?

4. The mean of four numbers is 21.
- Calculate the sum of the four numbers.
Six other numbers have a mean of 18.
 - Calculate the mean of the ten numbers.

5. Find:
 (a) the mean, (b) the median, (c) the mode,
 of the numbers 3, 1, 5, 4, 3, 8, 2, 3, 4, 1.

6. Marks	3	4	5	6	7	8
Number of pupils	2	3	6	4	3	2

The table shows the number of pupils in a class who scored marks 3 to 8 in a test. Find:

- (a) the mean mark,
 (b) the modal mark,
 (c) the median mark.
7. The mean height of 10 boys is 1.60 m and the mean height of 15 girls is 1.52 m. Find the mean height of the 25 boys and girls.

8. Mark	3	4	5
Number of pupils	3	x	4

The table shows the number of pupils who scored marks 3, 4 or 5 in a test. Given that the mean mark is 4.1, find x .

9. When two dice are thrown simultaneously, what is the probability of obtaining the same number on both dice?
10. A bag contains 20 discs of equal size of which 12 are red, x are blue and the rest are white.
 (a) If the probability of selecting a blue disc is $\frac{1}{4}$, find x .
 (b) A disc is drawn and then replaced. A second disc is drawn. Find the probability that neither disc is red.
11. Three dice are thrown. What is the probability that none of them shows a 1 or a 6?
12. A coin is tossed four times. What is the probability of obtaining at least three 'heads'?
13. A bag contains 8 balls of which 2 are red and 6 are white. A ball is selected and not replaced. A second ball is selected. Find the probability of obtaining:
 (a) two red balls,
 (b) two white balls,
 (c) one ball of each colour.
14. A bag contains x green discs and 5 blue discs. A disc is selected. A second disc is drawn. Find, in terms of x , the probability of selecting:
 (a) a green disc on the first draw,
 (b) a green disc on the first and second draws, if the first disc is replaced,
 (c) a green disc on the first and second draws, if the first disc is *not* replaced.

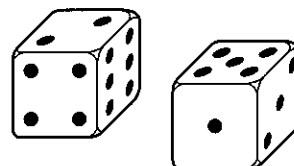

15. In a group of 20 people, 5 cannot swim. If two people are selected at random, what is the probability that neither of them can swim?
16. (a) What is the probability of winning the toss in five consecutive hockey matches?
 (b) What is the probability of winning the toss in all the matches in the FA cup from the first round to the final (i.e. 8 matches)?
17. Mr and Mrs Stringer have three children. What is the probability that:
 - (a) all the children are boys,
 - (b) there are more girls than boys?
 (Assume that a boy is as likely as a girl.)
18. The probability that it will be wet today is $\frac{1}{6}$. If it is dry today, the probability that it will be wet tomorrow is $\frac{1}{8}$. What is the probability that both today and tomorrow will be dry?
19. Two dice are thrown. What is the probability that the *product* of the numbers on top is:
 - (a) 12,
 - (b) 4,
 - (c) 11?
20. The probability of snow on January 1st is $\frac{1}{20}$. What is the probability that snow will fall on the next three January 1st?

Examination exercise 10B

1. In an election, people voted for parties A, B or C. The pie chart shows how the people voted.
 - (a) Calculate x .
 - (b) What fraction of the voters voted for party B? (Give your fraction in its lowest terms.)
 - (c) If 720 people voted for party A, how many voted for party B?

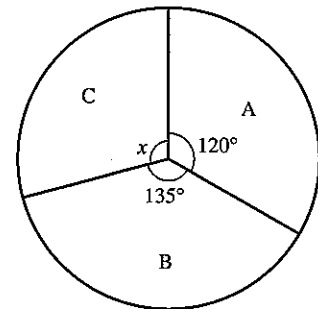

Not to scale

2. The median of $x - 4$, x , $2x$ and $2x + 12$ is 9, where x is a positive integer. Find the value of x .
3. The table shows the results of a short test.

mark	0	1	2	3	4	5
number of students	1	3	10	x	6	3

The mode of the marks is 2 and the median mark is 3. Find the possible values of x .



4. Answer the whole of this question on a sheet of graph paper.
The table shows the amount of money, \$ x , spent on books by a group of students.

amount spent (\$ x)	number of students
$0 < x \leq 10$	0
$10 < x \leq 20$	4
$20 < x \leq 30$	8
$30 < x \leq 40$	12
$40 < x \leq 50$	11
$50 < x \leq 60$	5

- (a) Calculate an estimate of the mean amount of money per student spent on books.
(b) Use the information in the table above to find the values of p , q and r in the following cumulative frequency table.

amount spent (\$ x)	cumulative frequency
$x \leq 10$	0
$x \leq 20$	4
$x \leq 30$	p
$x \leq 40$	q
$x \leq 50$	r
$x \leq 60$	40

- (c) Using a scale of 2 cm to represent 10 units on each axis, draw a cumulative frequency diagram.
(d) Use your diagram:
(i) to estimate the median amount spent,
(ii) to find the upper and lower quartiles, and the inter-quartile range.

N 96 4

5. Answer the whole of this question on a sheet of graph paper.
400 apples were weighed. Their masses are given in the table below.

mass (m grams)	frequency
$80 < m \leq 100$	50
$100 < m \leq 110$	70
$110 < m \leq 120$	113
$120 < m \leq 130$	92
$130 < m \leq 160$	75

- (a) Using a scale of 2 cm to represent 10 g on the horizontal axis, and an *area* scale of 1 cm^2 to represent 5 apples, draw a histogram to display this data.
(b) Calculate an estimate of the mean mass of the apples.
(c) A supermarket will only buy apples which have a mass greater than 110 g. What percentage of the apples does the supermarket buy?

N 98 4

6. Give each of your answers to this question as a fraction.
 Peter has 10 geranium plants. He knows that five will flower red, three pink and two white.

- (a) What is the probability that the first plant to flower is pink?
- (b) Copy the tree diagram. Write the correct probability on each branch.
- (c) What is the probability that, of the first two plants to flower:
 - (i) both are red,
 - (ii) one is red and the other is pink,
 - (iii) at least one is pink?
- (d) What is the probability that the first three plants to flower are all white?

N 98 4

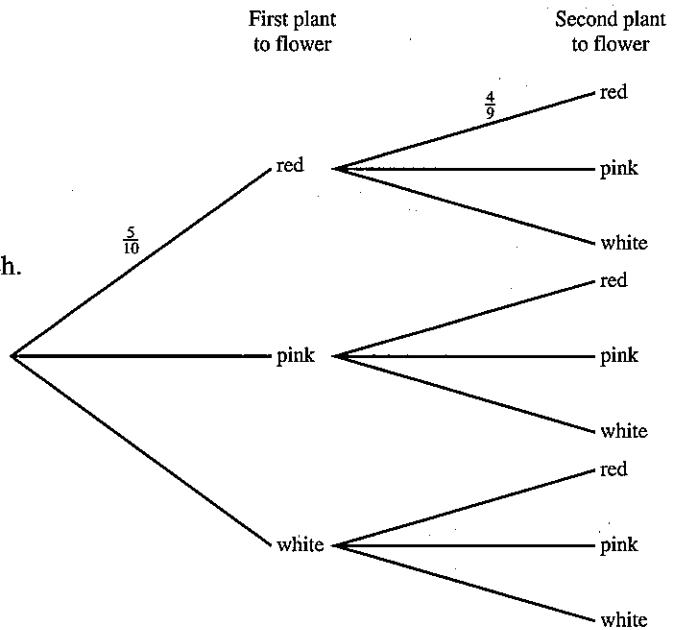

7. Give your answers to this question as fractions in their lowest terms. There are 21 students in a class. 12 are boys and 9 are girls. The teacher chooses two students at random.

- (a) If the first student chosen is a boy, explain why the probability that the second student chosen is also a boy is $\frac{11}{20}$.
- (b) Copy the tree diagram below. Write the correct probability on each branch.

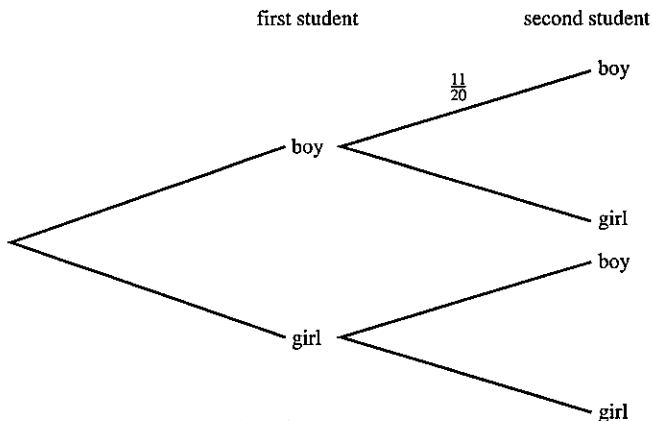

- (c) What is the probability that:
 - (i) both students are boys,
 - (ii) both students are girls,
 - (iii) one is a boy and one is a girl?
- (d) The teacher chooses a third student at random. What is the probability that;
 - (i) all three students are boys,
 - (ii) at least one of the three students is a girl?

J 96 4

8. Mamoud tries to repair a broken toy. Each time he tries the probability that he succeeds is 0.8. Each time he fails he tries again.
 (a) Copy and complete the tree diagram below.

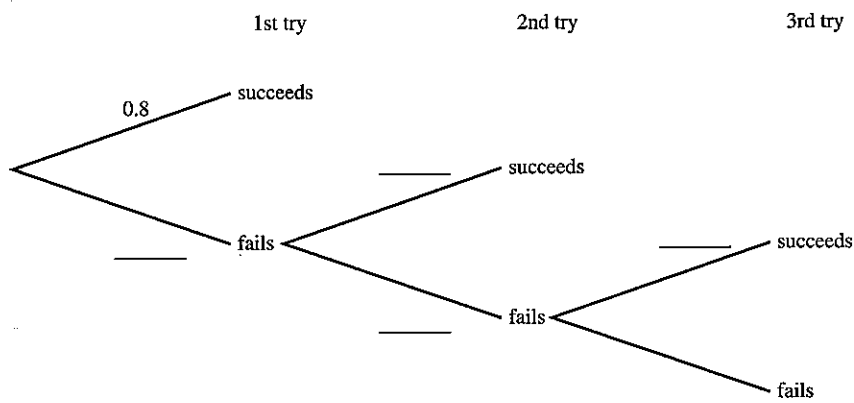

- (b) Find the probability that, to succeed, it takes:
 (i) exactly two tries,
 (ii) one, two or three tries,
 (iii) exactly five tries.
 (c) Write down a formula for the probability that he has not succeeded after n tries. J 89 4
9. Answer the whole of this question on a sheet of graph paper.
 120 passengers on an aircraft had their baggage weighed. The results are shown in the table.

Mass of baggage (M kg)	Number of passengers
$0 < M \leq 10$	12
$10 < M \leq 15$	32
$15 < M \leq 20$	28
$20 < M \leq 25$	24
$25 < M \leq 40$	24

- (a) (i) Write down the modal class.
 (ii) Calculate an estimate of the mean mass of baggage for the 120 passengers. Show all your working.
 (iii) Sophia draws a pie chart to show the data.
 What angle should she have in the $0 < M \leq 10$ sector?
- (b) Using a scale of 2 cm to represent 5 kg, draw a horizontal axis for $0 < M \leq 40$.
 Using an area scale of 1 cm^2 to represent 1 passenger, draw a histogram for this data. N 03 4

11 INVESTIGATIONS, PRACTICAL PROBLEMS, PUZZLES

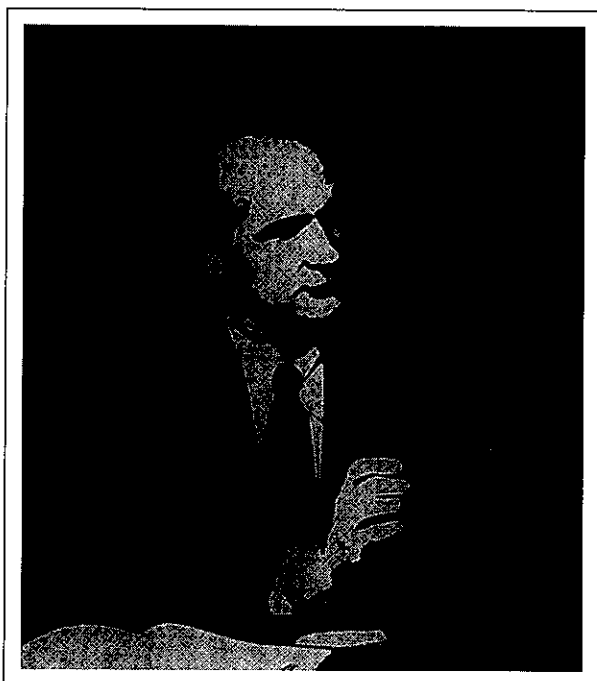

William Shockley Every time you use a calculator you are making use of integrated circuits which were developed from the first transistor. The transistor was invented by William Shockley, working with two scientists, in 1947. The three men shared the 1956 Nobel Prize for physics. The story of the invention is a good example of how mathematics can be used to solve practical problems.

The first electronic computers did not make use of transistors or integrated circuits and they were so big that they occupied whole rooms themselves. A modern computer which can carry out just the same functions can be carried around in a brief case.

11.1 Investigations

There are a large number of possible starting points for investigations here so it may be possible to allow students to choose investigations which appeal to them. On other occasions the same investigation may be set to a whole class.

Here are a few guidelines for you:

- If the set problem is too complicated try an easier case.
- Draw your own diagrams.
- Make tables of your results and be systematic.
- Look for patterns.
- Is there a rule or formula to describe the results?
- Can you *predict* further results?
- Can you *prove* any rules which you may find?



1. Opposite corners

Here the numbers are arranged in 10 columns.

1	2	3	4	5	6	7	8	9	10
11	12	13	14	15	16	17	18	19	20
21	22	23	24	25	26	27	28	29	30
31	32	33	34	35	36	37	38	39	40
41	42	43	44	45	46	47	48	49	50
51	52	53	54	55	56	57	58	59	60
61	62	63	64	65	66	67	68	69	70
71	72	73	74	75	76	77	78	79	80
81	82	83	84	85	86	87	88	89	90
91	92	93	94	95	96	97	98	99	100

In the 2×2 square

$$7 \times 18 = 126$$

$$8 \times 17 = 136$$

7	8
17	18

the difference between them is 10.

In the 3×3 square

$$12 \times 34 = 408$$

$$14 \times 32 = 448$$

12	13	14
22	23	24
32	33	34

the difference between them is 40.

Investigate to see if you can find any rules or patterns connecting the size of square chosen and the difference.

If you find a rule, use it to *predict* the difference for larger squares.

Test your rule by looking at squares like 8×8 or 9×9 .

Can you *generalise* the rule?

[What is the difference for a square of size $n \times n$?]

x		?
?		?

Can you prove the rule?

Hint:

In a 3×3 square ...

What happens if the numbers are arranged in six columns or seven columns?

1	2	3	4	5	6
7	8	9	10	11	12
13	14	15	16	17	18
19	-----				

1	2	3	4	5	6	7
8	9	10	11	12	13	14
15	16	17	18	19	20	21
22	-----					

2. Weighing scales

In the diagram we are measuring the weight of the package x using two weights.

If the scales are balanced, x must be 2 kg.

Show how you can measure all the weights from 1 kg to 10 kg using three weights: 1 kg, 3 kg, 6 kg.

It is possible to measure all the weights from 1 kg to 13 kg using a different set of three weights. What are the three weights?

It is possible to measure all the weights from 1 kg to 40 kg using four weights. What are the weights?

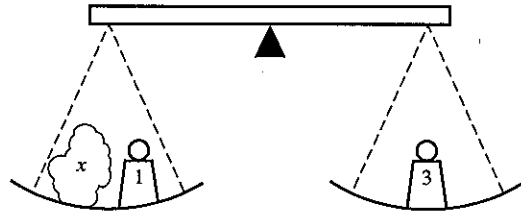

3. Buying stamps

You have one 1c, one 2c, one 5c and one 10c coin.

You can buy stamps of any value you like, but you must give the exact money.

How many different value stamps can you buy?

Suppose you now have one 1c, one 2c, one 5c, one 10c, one 20c, one 50c and one \$1 note.

How many different value stamps can you buy now?

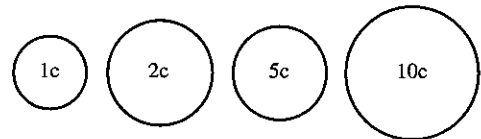

4. Frogs

This is a game invented by a French mathematician called Lucas.

Aim: To swap the positions of the discs so that they end up the other way round (with a space in the middle).

Rules 1. A disc can slide one square in either direction onto an empty square.

2. A disc can hop over one adjacent disc of the other colour provided it can land on an empty square.

Example (a) Slide (A) one square to the right.

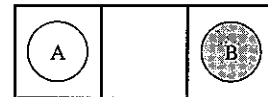

(b) (B) hops over (A) to the left.

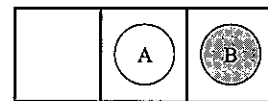

(c) Slide (A) one square to the right.

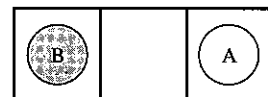
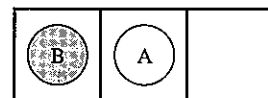

We took 3 moves.

1. Look at the diagram. What is the smallest number of moves needed for two discs of each colour?

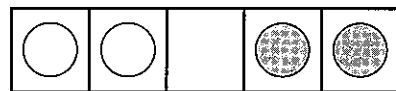

2. Now try three discs of each colour. Can you complete the task in 15 moves?

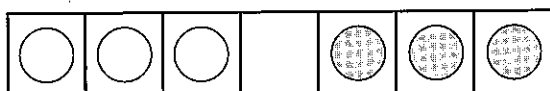

3. Try four discs of each colour.
 Now look at your results and try to find a formula which gives the least number of moves needed for any number of discs x . It may help if you count the number of 'hops' and 'slides' separately.
4. Try the game with a different number of discs on each side.
 Say two reds and three blues. Play the game with different combinations and again try to find a formula giving the number of moves for x discs of one colour and y discs of another colour.

5. Triples

In this investigation a *triple* consists of three whole numbers in a definite order. For example, (4, 2, 1) is a triple and (1, 4, 2) is a different triple.

The three numbers in a triple do not have to be different. For example, (2, 2, 3) is a triple but (2, 0, 1) is not a triple because 0 is not allowed.

The *sum* of a triple is found by adding the three numbers together. So the sum of (4, 2, 1) is 7.

Investigate how many different triples there are with a given sum. See what happens to the number of different triples as the sum is changed.

If you find any pattern, try to explain why it occurs.

How many different triples are there whose sum is 22?

6. Mystic rose

Straight lines are drawn between each of the 12 points on the circle. Every point is joined to every other point. How many straight lines are there?

Suppose we draw a mystic rose with 24 points on the circle. How many straight lines are there?
 How many straight lines would there be with n points on the circle?

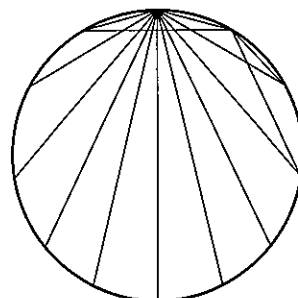

7. Knockout competition

Eight teams reach the 'knockout' stage of the World Cup.

England	2	}	England	1	}	Brazil	1
Germany	1		Brazil	3			
France	0	}	Argentina	0	}	Morocco	2
Brazil	1		Italy	0			
Argentina	3	Scotland	2				
Italy	0	Morocco	3				

How would you organise a knockout competition if there were 12 teams? Or 15?

How many matches are played up to and including the final if there are:

- (a) 8 teams,
- (b) 12 teams,
- (c) 15 teams,
- (d) 23 teams,
- (e) n teams?

In a major tournament like Wimbledon, the better players are seeded from 1 to 16. Can you organise a tournament for 32 players so that, if they win all their games:

- (a) seeds 1 and 2 can meet in the final,
- (b) seeds 1, 2, 3 and 4 can meet in the semi-finals,
- (c) seeds 1, 2, 3, 4, 5, 6, 7, 8 can meet in the quarter-finals?

8. Discs

- (a) You have five black discs and five white discs which are arranged in a line as shown.



We want to get all the black discs to the right-hand end and all the white discs to the left-hand end.



The only move allowed is to interchange two neighbouring discs.

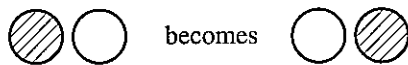

How many moves does it take?

How many moves would it take if we had fifty black discs and fifty white discs arranged alternately?

(b) Suppose the discs are arranged in pairs



How many moves would it take if we had fifty black discs and fifty white discs arranged like this?

[Hint: In both cases work with a smaller number of discs until you can see a pattern.]

(c) Now suppose you have three colours black, white and green arranged alternately.

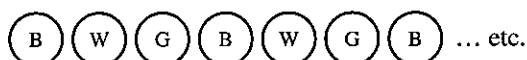

You want to get all the black discs to the right, the green discs to the left and the white discs in the middle.

How many moves would it take if you have 30 discs of each colour?

9. Chess board

Start with a small board, just 4×4 .

How many squares are there? [It is not just 16!]

How many squares are there on an 8×8 chess board?

How many squares are there on an $n \times n$ chess board?

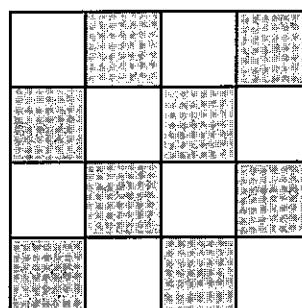

10. Area and perimeter

This is about finding different shapes in which the area is numerically equal to the perimeter.

This rectangle has an area of 10 square units and a perimeter of 14 units, so we will have to try another one.

There are some suggestions below but you can investigate shapes of your own choice if you prefer.

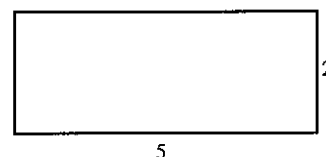

(a) Find rectangles with equal area and perimeter. After a while you can try adding on bits like this.

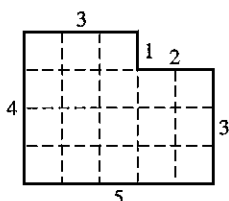

area = 18
perimeter = 18

- (b) Suppose one dimension of the rectangle is fixed.
In this rectangle the length is 5 units.

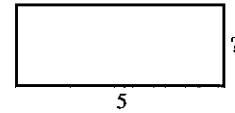

- (c) Try right-angled triangles and equilateral triangles.
 (d) Try circles, semi-circles and so on.
 (e) How about three-dimensional shapes? Now we are looking for cuboids, spheres, cylinders in which the volume is numerically equal to the surface area.
 (f) Can you find any connection between the square with equal area and perimeter and the circle with equal area and perimeter? How about the equilateral triangle with equal area and perimeter?

11. Happy numbers (and more)

- (a) Take the number 23.
Square the digits and add.

$$\begin{array}{r} 2 \quad 3 \\ 2^2 + 3^2 = 1 \quad 3 \\ \quad 1^2 + 3^2 = 1 \quad 0 \\ \qquad 1^2 + 0^2 = 1 \end{array}$$

The sequence ends at 1 and we call 23 a 'happy' number.
Investigate for other numbers. Here are a few suggestions: 70, 85, 49, 44, 14, 15, 94.

- (b) Now change the rule. Instead of squaring the digits we will cube them.

$$\begin{array}{r} 2 \quad 1 \\ 2^3 + 1^3 = 0 \quad 9 \\ \quad 0^3 + 9^3 = 7 \quad 2 \quad 9 \\ \qquad 7^3 + 2^3 + 9^3 = 1 \quad 0 \quad 8 \quad 0 \\ \qquad \qquad 1^3 + 0^3 + 8^3 = 5 \quad 1 \quad 3 \\ \qquad \qquad \qquad 5^3 + 1^3 + 3^3 = 153 \end{array}$$

And now we are stuck because 153 leads to 153 again.
Investigate for numbers of your own choice. Do any numbers lead to 1?

12. Prime numbers

Write all the numbers from 1 to 104 in eight columns and draw a ring around the prime numbers 2, 3, 5 and 7.

1	②	③	4	⑤	6	⑦	8
9	10	11	12	13	14	15	16
17	18	19	20	21	22	23	24
25							



If we cross out all the multiples of 2, 3, 5 and 7, we will be left with all the prime numbers below 104. Can you see why this works?

Draw *four* lines to eliminate the multiples of 2.

Draw *six* lines to eliminate the multiples of 3.

Draw *two* lines to eliminate the multiples of 7.

Cross out all the numbers ending in 5.

Put a ring around all the prime numbers less than 104.

[Check there are 27 numbers.]

Many prime numbers can be written as the sum of two squares.

For example $5 = 2^2 + 1^2$, $13 = 3^2 + 2^2$. Find all the prime numbers in your table which can be written as the sum of two squares. Draw a red ring around them in the table.

What do you notice?

Check any 'gaps' you may have found.

Extend the table up to 200 and see if the pattern continues. In this case you will need to eliminate the multiples of 11 and 13 as well.

13. Squares

For this investigation you need either dotted paper or squared paper.

The shaded square has an area of 1 unit.

Can you draw a square, with its corners on the dots, with an area of 2 units?

Can you draw a square with an area of 3 units?

Can you draw a square with an area of 4 units?

Investigate for squares up to 100 units.

For which numbers x can you draw a square of area x units?

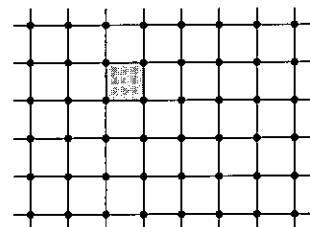

14. Painting cubes

The large cube below consists of 27 unit cubes. All six faces of the large cube are painted green.

How many unit cubes have 3 green faces?

How many unit cubes have 2 green faces?

How many unit cubes have 1 green face?

How many unit cubes have 0 green faces?

Suppose the large cube is $20 \times 20 \times 20$.

Answer the four questions above.

Answer the four questions for the cube which is $n \times n \times n$.

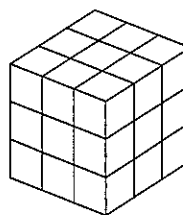

15. Final score

The final score in a football match was 3–2. How many different scores were possible at half-time?

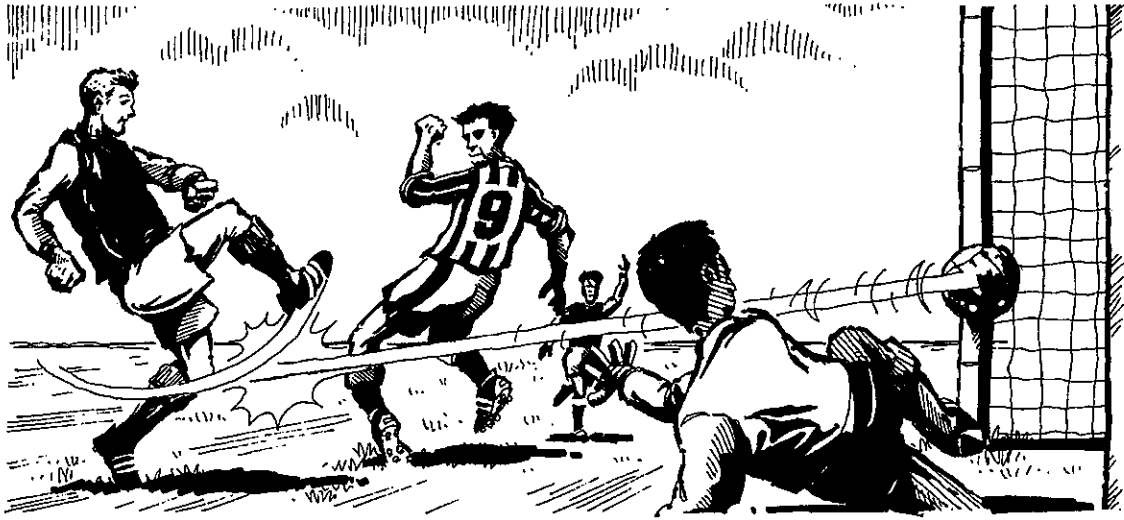

Investigate for other final scores where the difference between the teams is always one goal [1–0, 5–4 etc]. Is there a pattern or rule which would tell you the number of possible half-time scores in a game which finished 58–57?

Suppose the game ends in a draw. Find a rule which would tell you the number of possible half-time scores if the final score was 63–63.

Investigate for other final scores [3–0, 5–1, 4–2 etc].

16. Cutting paper

The rectangle ABCD is cut in half to give two smaller rectangles.

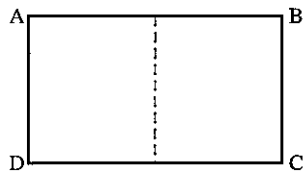

Each of the smaller rectangles is mathematically similar to the large rectangle. Find a rectangle which has this property.

What happens when the small rectangles are cut in half? Do they have the same property?

Why is this a useful shape for paper used in business?

17. Matchstick shapes

(a) Here we have a sequence of matchstick shapes

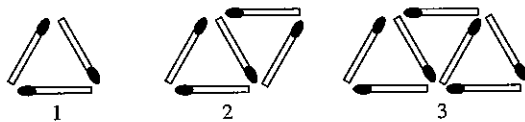

Can you work out the number of matches in the 10th member of the sequence? Or the 20th member of the sequence? How about the n th member of the sequence?

(b) Now try to answer the same questions for the patterns below. Or you may prefer to design patterns of your own.

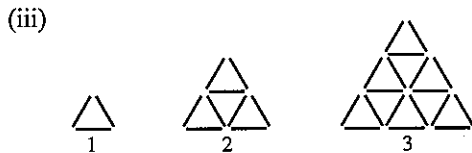
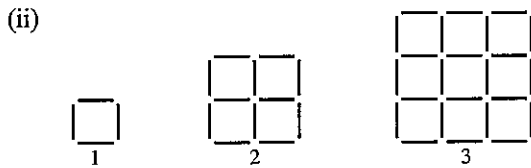
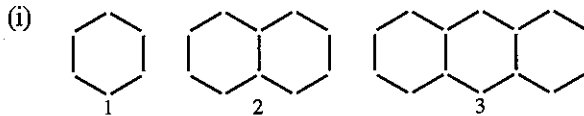

18. Maximum box

(a) You have a square sheet of card 24 cm by 24 cm. You can make a box (without a lid) by cutting squares from the corners and folding up the sides.

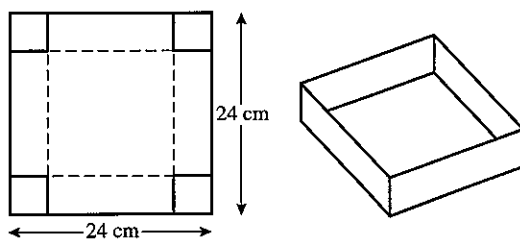

What size corners should you cut out so that the volume of the box is as large as possible?

Try different sizes for the corners and record the results in a table:

length of the side of the corner square (cm)	dimensions of the open box (cm)	volume of the box (cm ³)
1	22 × 22 × 1	484
2		
—		
—		

Now consider boxes made from different sized cards:
15 cm × 15 cm and 20 cm by 20 cm.

What size corners should you cut out this time so that the volume of the box is as large as possible?

Is there a connection between the size of the corners cut out and the size of the square card?

- (b) Investigate the situation when the card is not square. Take rectangular cards where the length is twice the width (20 × 10, 12 × 6, 18 × 9 etc). Again, for the maximum volume is there a connection between the size of the corners cut out and the size of the original card?

19. Digit sum

Take the number 134.
Add the digits 1 + 3 + 4 = 8.
The digit sum of 134 is 8.

Take the number 238.
2 + 3 + 8 = 13 [We continue if the sum is more than 9].
1 + 3 = 4

The digit sum of 238 is 4.
Consider the multiples of 3:

Number	3	6	9	12	15	18	21	24	27	30	33	36
Digit sum	3	6	9	3	6	9	3	6	9	3	6	9

The digit sum is always 3, 6, or 9.
These numbers can be shown on a circle.

Investigate the pattern of the digit sums for multiples of:

- (a) 2 (b) 5 (c) 6 (d) 7 (e) 8
(f) 9 (g) 11 (h) 12 (i) 13

Is there any connection between numbers where the pattern of the digit sums is the same?

Can you (without doing all the usual working) predict what the pattern would be for multiples of 43? Or 62?

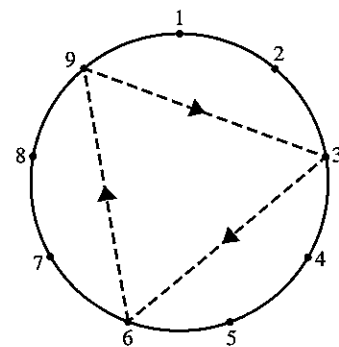

20. An expanding diagram

Look at the series of diagrams below.

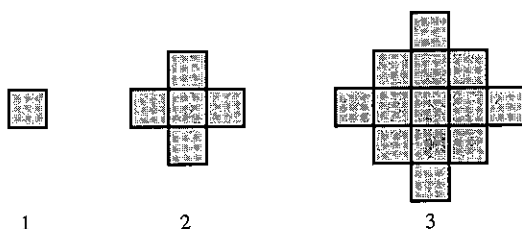

Each time new squares are added all around the outside of the previous diagram.

Draw the next few diagrams in the series and count the number of squares in each one.

How many squares are there in diagram number 15 or in diagram number 50?

What happens if we work in three dimensions? Instead of adding squares we add cubes all around the outside. How many cubes are there in the fifth member of the series or the fifteenth?

21. Fibonacci sequence

Fibonacci was the nickname of the Italian mathematician Leonardo de Pisa (A.D. 1170–1250). The sequence which bears his name has fascinated mathematicians for hundreds of years. You can if you like join the Fibonacci Association which was formed in 1963.

Here is the start of the sequence
1, 1, 2, 3, 5, 8, 13, 21, 34, 55, 89, 144, ...

There are no prizes for working out the next term!

The sequence has many interesting properties to investigate. Here are a few suggestions.

(a) Add three terms.

$$1 + 1 + 2, 1 + 2 + 3, \text{ etc.}$$

Add four terms.

(b) Add squares of terms

$$1^2 + 1^2, 1^2 + 2^2, 2^2 + 3^2, \dots$$

(c) Ratios

$$\frac{1}{1} = 1, \frac{2}{1} = 2, \frac{3}{2} = 1.5, \dots$$

(d) In fours $\boxed{2 \ 3 \ 5 \ 8}$

$$2 \times 8 = 16, 3 \times 5 = 15$$

(e) In threes $\boxed{3 \ 5 \ 8}$

$$3 \times 8 = 24, 5^2 = 25$$

(f) In sixes $\boxed{1 \ 1 \ 2 \ 3 \ 5 \ 8}$

square and add the first five numbers

$$1^2 + 1^2 + 2^2 + 3^2 + 5^2 = 40$$

$$5 \times 8 = 40.$$

Now try seven numbers from the sequence, or eight ...

(g) Take a group of 10 consecutive terms. Compare the sum of the 10 terms with the seventh member of the group.

22. Alphabetical order

A teacher has four names on a piece of paper which are in no particular order (say Smith, Jones, Biggs, Eaton). He wants the names in alphabetical order.

One way of doing this is to interchange each pair of names which are clearly out of order.

So he could start like this; S J B E

the order becomes J S B E

He would then interchange S and B.

Using this method, what is the largest number of interchanges he could possibly have to make?

What if he had thirty names, or fifty?

23. Mr Gibson's job

Mr Gibson's job is counting tiles of the black or white variety. When he is bored Mr Gibson counts the tiles by placing them in a pattern consisting of alternate black and white tiles. This one is five tiles across and altogether there are 13 tiles in the pattern.

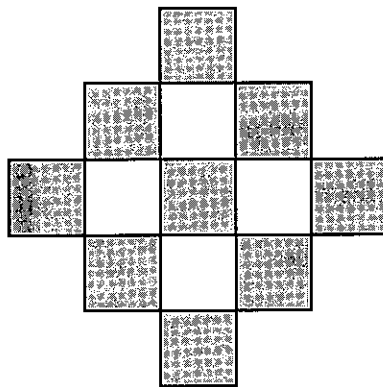

He makes the pattern so that there are always black tiles all around the outside. Draw the pattern which is nine tiles across. You should find that there are 41 tiles in the pattern.

How many tiles are there in the pattern which is 101 tiles across?

24. Diagonals

In a 4×7 rectangle the diagonal passes through 10 squares.

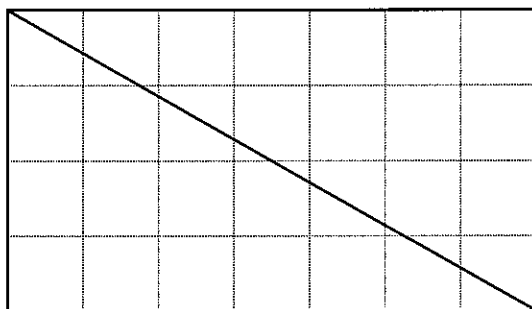

Draw rectangles of your own choice and count the number of squares through which the diagonal passes.

A rectangle is 640×250 . How many squares will the diagonal pass through?

25. Biggest number

A calculator has the following buttons:

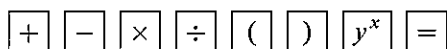

Also the only digits buttons which work are the '1', '2' and '3'.

- You can press any button, but only once.
What is the biggest number you can get?
- Now the '1', '2', '3' and '4' buttons are working.
What is the biggest number you can get?
- Investigate what happens as you increase the number of digits which you can use.

26. What shape tin?

We need a cylindrical tin which will contain a volume of 600 cm^3 of drink.

What shape should we make the tin so that we use the minimum amount of metal?

In other words, for a volume of 600 cm^3 , what is the smallest possible surface area?

Hint: Make a table.

r	h	A
2	?	?
3	?	?
\vdots		

What shape tin should we design to contain a volume of 1000 cm^3 ?



27. Find the connection

Work through the flow diagram several times, using a calculator.

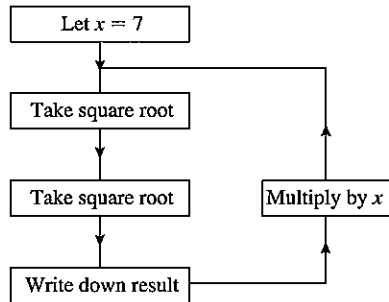

What do you notice?

Try different numbers for x (suggestions: 11, 5, 8, 27)

What do you notice?

What happens if you take the square root three times?

Suppose in the flow diagram you change 'Multiply by x ' to 'Divide by x '. What happens now?

Suppose in the flow diagram you change 'Multiply by x ' to 'Multiply by x^2 '. What happens now?

28. Spotted shapes

For this investigation you need dotted paper. If you have not got any, you can make your own using a felt tip pen and squared paper.

The rectangle in Diagram 1 has 10 dots on the perimeter ($p = 10$) and 2 dots inside the shape ($i = 2$). The area of the shape is 6 square units ($A = 6$)

The triangle in Diagram 2 has 9 dots on the perimeter ($p = 9$) and 4 dots inside the shape ($i = 4$). The area of the triangle is $7\frac{1}{2}$ square units ($A = 7\frac{1}{2}$)

Draw more shapes of your own design and record the values for p, i and A in a table. Make some of your shapes more difficult like the one in Diagram 3.

Can you find a formula connecting p, i and A ?

[Hint: $\frac{1}{2}i, \frac{1}{2}p$]

Try out your formula with some more shapes to see if it always works.

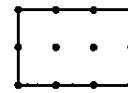

Diagram 1

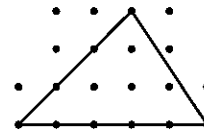

Diagram 2

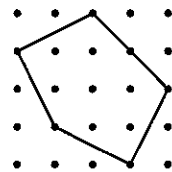
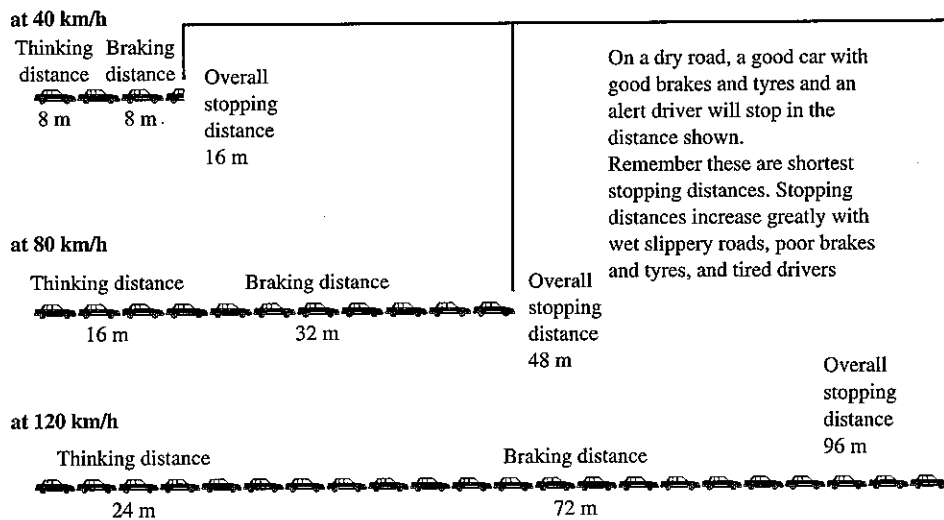

Diagram 3



29. Stopping distances



This diagram from the Highway Code gives the overall stopping distances for cars travelling at various speeds.

What is meant by 'thinking distance'?

Work out the thinking distance for a car travelling at a speed of 90 km/h. What is the formula which connects the speed of the car and the thinking distance?

(More difficult)

Try to find a formula which connects the speed of the car and the overall stopping distance. It may help if you draw a graph of speed (across the page) against braking distance (up the page).

What curve are you reminded of?

Check that your formula gives the correct answer for the overall stopping distance at a speed of:

- (a) 40 km/h (b) 120 km/h.

30. Maximum cylinder

A rectangular piece of paper has a fixed perimeter of 40 cm.

It could for example be 7 cm × 13 cm.

This paper can make a hollow cylinder of height 7 cm or of height 13 cm.

Work out the volume of each cylinder.

What dimensions should the paper have so that it can make a cylinder of the maximum possible volume?

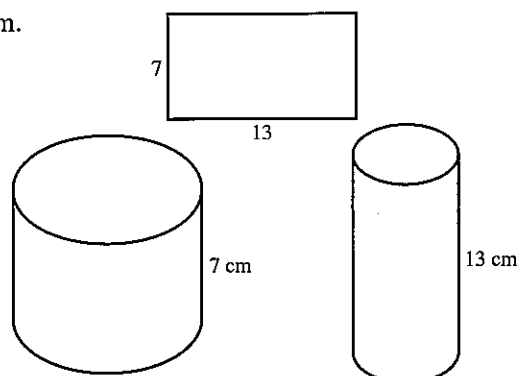

11.2 Practical problems

1. Timetabling

(a) Every year a new timetable has to be written for the school. We will look at the problem of writing the timetable for one department (mathematics). The department allocates the teaching periods as follows:

- Upper 6 2 sets (at the same times); 8 periods in 4 doubles.
- Lower 6 2 sets (at the same times); 8 periods in 4 doubles.
- Year 5 6 sets (at the same times); 5 single periods.
- Year 4 6 sets (at the same times); 5 single periods.
- Year 3 6 sets (at the same times); 5 single periods.
- Year 2 6 sets (at the same times); 5 single periods.
- Year 1 5 mixed ability forms; 5 single periods not necessarily at the same times.

Here are the teachers and the maximum number of maths periods which they can teach.

- A 33
- B 33
- C 33
- D 20
- E 20
- F 15 (must be years 5, 4, 3)
- G 10 (must be years 2, 1)
- H 10 (must be years 2, 1)
- I 5 (must be year 3)

Furthermore, to ensure some continuity of teaching, teachers B and C must teach the U6 (Upper Sixth) and teachers A, B, C, D, E, F must teach year 5.

Here is a timetable form which has been started:

M	5				U6 B, C	U6 B, C		
Tu		5	U6 B, C	U6 B, C				
W					5			
Th						5	U6 B, C	U6 B, C
F	U6 B, C	U6 B, C		5				

Your task is to write a complete timetable for the mathematics department subject to the restrictions already stated.

(b) If that was too easy, here are some changes.

U6 and L6 have 4 sets each (still 8 periods)

Two new teachers: J 20 periods maximum

K 15 periods maximum but cannot teach on Mondays.

Because of games lessons: A cannot teach Wednesday afternoon

B cannot teach Tuesday afternoon

C cannot teach Friday afternoon

Also: A, B, C and E must teach U6

A, B, C, D, E, F must teach year 5

For the pupils, games afternoons are as follows:

Monday year 2; Tuesday year 3; Wednesday 5 L6, U6;

Thursday year 4; Friday year 1.

2. Hiring a car

You are going to hire a car for one week (seven days).

Which of the firms below should you choose?

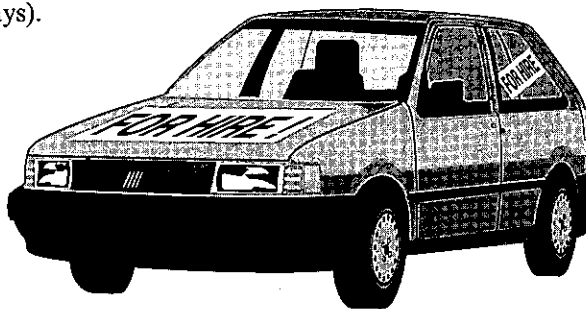

Gibson car hire	Snowdon rent-a-car	Hav-a-car
\$170 per week no charge up to 10 000 km	\$10 per day 6.5c per km	\$60 per week 500 km without charge 22c per km over 500 km

Work out as detailed an answer as possible.

3. Running a business

Mr Singh runs a small business making two sorts of steam cleaner: the basic model B and the deluxe model D.

Here are the details of the manufacturing costs:

	model B	model D
Assembly time (in man-hours)	20 hours	30 hours
Component costs	\$35	\$25
Selling price	\$195	\$245

He employs 10 people and pays them each \$160 for a 40-hour week. He can spend up to \$525 per week on components.

- (a) In one week the firm makes and sells six cleaners of each model. Does he make a profit?
[Remember he has to pay his employees for a full week.]
- (b) What number of each model should he make so that he makes as much profit as possible? Assume he can sell all the machines which he makes.

4. How many of each?

A shop owner has room in her shop for up to 20 televisions. She can buy either type A for \$150 each or type B for \$300 each.

She has a total of \$4500 she can spend and she must have at least 6 of each type in stock. She makes a profit of \$80 on each television of type A and a profit of \$100 on each of type B.

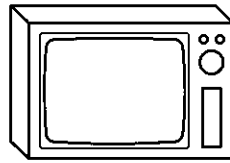

A cost \$150

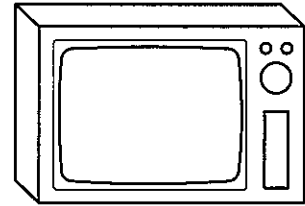

B cost \$300

How many of each type should she buy so that she makes the maximum profit?

11.3 Puzzles and experiments

1. Cross numbers

- (a) Copy out the cross number pattern.
- (b) Fit all the given numbers into the correct spaces. Tick off the numbers from the lists as you write them in the square.

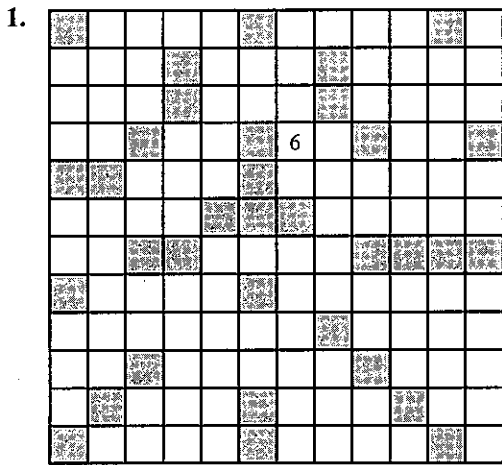

2 digits	3 digits	4 digits	5 digits	6 digits
11	121	2104	14 700	216 841
17	147	2356	24 567	588 369
18	170	2456	25 921	846 789
19	174	3714	26 759	861 277
23	204	4711	30 388	876 452
31	247	5548	50 968	
37	287	5678	51 789	
58	324	6231	78 967	
61	431	6789	98 438	
62	450	7630		7 digits
62	612	9012		6 645 678
70	678	9921		
74	772			
81	774			
85	789			
94	870			
99				

2.

2 digits	3 digits	4 digits	5 digits	6 digits
12 47	129	2096	12 641	324 029
14 48	143	3966	23 449	559 641
16 54	298	5019	33 111	956 782
18 56	325	5665	33 210	
20 63	331	6462	34 509	
21 67	341	7809	40 551	
23 81	443	8019	41 503	
26 90	831	8652	44 333	7 digits
27 91	923		69 786	1 788 932
32 93			88 058	5 749 306
38 98			88 961	
39 99			90 963	
46			94 461	
			99 654	

2. Estimating game

This is a game for two players. On squared paper draw an answer grid with the numbers shown below.

Answer grid

891	7047	546	2262	8526	429
2548	231	1479	357	850	7938
663	1078	2058	1014	1666	3822
1300	1950	819	187	1050	3393
4350	286	3159	442	2106	550
1701	4050	1377	4900	1827	957

The players now take turns to choose two numbers from the question grid below and multiply them on a calculator.

Question grid

11	26	81
17	39	87
21	50	98

The game continues until all the numbers in the answer grid have been crossed out. The object is to get four answers in a line (horizontally, vertically or diagonally). The winner is the player with most lines of four.

A line of *five* counts as *two* lines of four.

A line of *six* counts as *three* lines of four.

3. The chess board problem

- (a) On the 4×4 square below we have placed four objects subject to the restriction that nowhere are there two objects on the same row, column or diagonal.

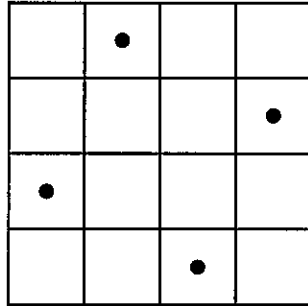

Subject to the same restrictions:

- (i) find a solution for a 5×5 square, using five objects,
- (ii) find a solution for a 6×6 square, using six objects,
- (iii) find a solution for a 7×7 square, using seven objects,
- (iv) find a solution for a 8×8 square, using eight objects.

It is called the chess board problem because the objects could be 'Queens' which can move any number of squares in any direction.

- (b) Suppose we remove the restriction that no two Queens can be on the same row, column or diagonal. Is it possible to attack every square on an 8×8 chess board with less than eight Queens?

Try the same problem with other pieces like knights or bishops.

4. Creating numbers

Using only the numbers 1, 2, 3 and 4 once each and the operations $+$, $-$, \times , \div , $!$ create every number from 1 to 100.

You can use the numbers as powers and you must use all of the numbers 1, 2, 3 and 4.

[$4!$ is pronounced 'four factorial' and means $4 \times 3 \times 2 \times 1$ (i.e. 24)

similarly $3! = 3 \times 2 \times 1 = 6$

$5! = 5 \times 4 \times 3 \times 2 \times 1 = 120$]

Examples: $1 = (4 - 3) \div (2 - 1)$

$20 = 4^2 + 3 + 1$

$68 = 34 \times 2 \times 1$

$100 = (4! + 1)(3! - 2!)$



5. Pentominoes

A pentomino is a set of five squares joined along their edges. Here are three of the twelve different pentomino designs.

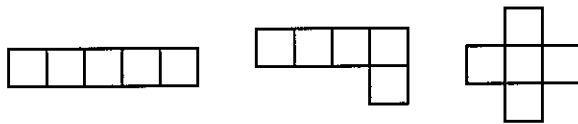

- (a) Find the other nine pentomino designs to make up the complete set of twelve. Reflections or rotations of other pentominoes are not allowed.
- (b) On squared paper draw an 8×8 square. It is possible to fill up the 8×8 square with the twelve different pentominoes together with a 2×2 square. Here we have made a possible start.

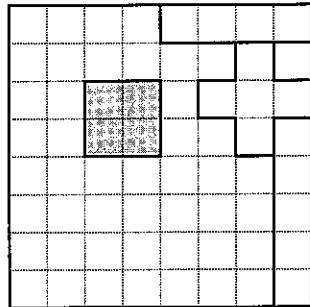

There are in fact many different ways in which this can be done.

- (c) Now draw a 10×6 rectangle. Try to fill up the rectangle with as many different pentominoes as you can. This problem is more difficult than the previous one but it is possible to fill up the rectangle with the twelve different pentominoes.

6. Calculator words

On a calculator work out $9508^2 + 192^2 + 10^2 + 6$. If you turn the calculator upside down and use a little imagination, you can see the word 'HEDGEHOG'.

Find the words given by the clues below.

- $19 \times 20 \times 14 - 2.66$ (not an upstanding man)
- $(84 + 17) \times 5$ (dotty message)
- $904^2 + 89\,621\,818$ (prickly customer)
- $(559 \times 6) + (21 \times 55)$ (what a surprise!)
- $566 \times 711 - 23\,617$ (bolt it down)
- $\frac{9999 + 319}{8.47 + 2.53}$ (sit up and plead)
- $\frac{2601 \times 6}{4^2 + 1^2}$; $(401 - 78) \times 5^2$ (two words) (not a great man)

8. $0.4^2 - 0.1^2$ (little Sidney)
9. $\frac{(27 \times 2000 - 2)}{(0.63 \div 0.09)}$ (not quite a mountain)
10. $(5^2 - 1^2)^4 - 14239$ (just a name)
11. $48^4 + 102^2 - 4^2$ (pursuits)
12. $615^2 + (7 \times 242)$ (almost a goggle)
13. $(130 \times 135) + (23 \times 3 \times 11 \times 23)$ (wobbly)
14. $164 \times 166^2 + 734$ (almost big)
15. $8794^2 + 25 \times 342.28 + 120 \times 25$ (thin skin)
16. $0.08 - (3^2 \div 10^4)$ (ice house)
17. $235^2 - (4 \times 36.5)$ (shiny surface)
18. $(80^2 + 60^2) \times 3 + 81^2 + 12^2 + 3013$ (ship gunge)
19. $3 \times 17 \times (329^2 + 2 \times 173)$ (unlimited)
20. $230 \times 230\frac{1}{2} + 30$ (fit feet)
21. $33 \times 34 \times 35 + 15 \times 3$ (beleaguer)
22. $0.32^2 + \frac{1}{1000}$ (Did he or didn't he?)
23. $(23 \times 24 \times 25 \times 26) + (3 \times 11 \times 10^3) - 20$ (help)
24. $(16^2 + 16)^2 - (13^2 - 2)$ (slander)
25. $(3 \times 661)^2 - (3^6 + 22)$ (pester)
26. $(22^2 + 29.4) \times 10; (3.03^2 - 0.02^2) \times 100^2$ (four words) (Goliath)
27. $1.25 \times 0.2^6 + 0.2^2$ (tissue time)
28. $(710 + (1823 \times 4)) \times 4$ (liquor)
29. $(3^3)^2 + 2^2$ (wiggler)
30. $14 + (5 \times (83^2 + 110))$ (bigger than a duck)
31. $2 \times 3 \times 53 \times 10^4 + 9$ (opposite to hello, almost!)
32. $(177 \times 179 \times 182) + (85 \times 86) - 82$ (good salesman)
33. $14^4 - 627 + 29$ (good book, by God!)
34. $6.2 \times 0.987 \times 1\,000\,000 - 860^2 + 118$ (flying ace)
35. $(426 \times 474) + (318 \times 487) + 22\,018$ (close to a bubble)